

INSTALLATION NOTES

1. Disconnect the negative battery cable. Remove the air cleaner assembly. (Draining the engine coolant and removing the upper radiator hose will make removing the fan shroud easier, but is not necessary). Remove the bolts from the top half of the fan shroud and remove it. Remove the fan assembly. **Fan nut has right hand threads. NOTE: Only use approved tools to remove and install fan. If an air chisel or similar is used on the fan nut, water pump bearing or shaft failure can occur!**
2. Remove the engine drive belt and tensioner. Remove the engine oil fill tube, dipstick tube, and the bracket from the front of the cylinder head. Remove the bolt from the harmonic damper and install the new pulley and pulley adapter (1,2) with bolt (3) and set screws (5). Torque bolt (3) to 240 ft./lbs. Cross torque set screws (5) at 10 in./lbs., 5 ft./lbs., 15 ft./lbs., and then 25 ft./lbs.
3. Install the main bracket (7) onto the engine at the OEM tensioner location using bolts (12,13) and lock washers (11). Torque bolts to 30 ft. lbs. Install the angle brace (8) with bolts (14) into the front of the cylinder head and the back of the bracket. Tighten all four bolts lightly then torque them to 30 ft. lbs. Install the grooved idler (22) into the top hole of the main bracket with bolt (23) and spacer (21). Remove the three bolts from the alternator bracket just below the alternator. Install the new tensioner plate (9) with bolts (15). Install the tensioner (27) onto bracket (9) using bolt (26). **The belt needs to be behind the tensioner before it's tightened.** Install the OEM belt.
4. Install oil fill tube standoff (10) using bolts (24). Install the A/C compressor with bolts provided. Install the A/C tensioner and belt. Fan shroud may need to be trimmed to clear aftermarket components. Install fan spacer nut (28) and re-install fan. Check for adequate clearance. Replace fan shroud. Cut oil fill tube as shown in the illustration. Replace oil fill and dipstick tube using bolt (17), clamps (19,20), lock washer (16) and nut (18). Replace upper radiator hose and engine coolant if removed. Replace air cleaner assembly.
5. Check all hoses, wires, etc. that were disturbed during the installation to make sure they do not come in contact with any hot or moving parts. Run engine and check for proper belt tracking.

VCK 39SD508-6
2006-2017 Chevy
G 1500-3500
4.8, 5.3, 6.0 VortecV-8
W-WO/AC
W/O EGR Valve

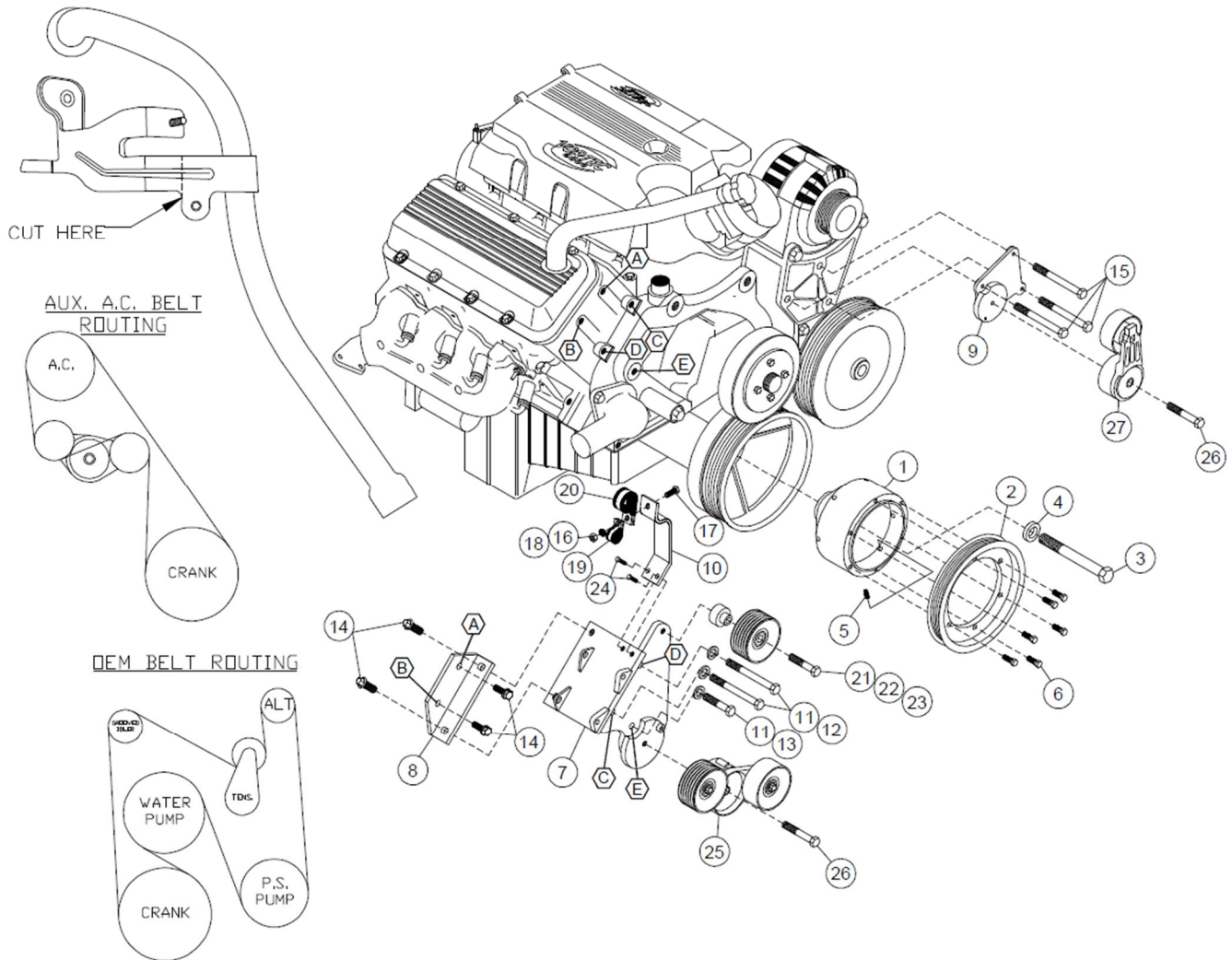

PARTS LIST

- | | |
|-------------------------------|---------------------------------|
| 1. CPA382 (1) | 18. 1/4 NC (1) |
| 2. CPC386-7.5 (1) | 19. #14 Adel Clamp (1) |
| 3. 16mm x 140mm (1) | 20. #16 Adel Clamp (1) |
| 4. 16mm FW (1) | 21. VCMB394 (1) |
| 5. 8mm x 20mm Set Screw (6) | 22. 89051Dayco (1) |
| 6. 8mm x 25mm Flange Bolt (6) | 23. 10mm x 40mm Flange (1) |
| 7. VCMP39SD508-6 (1) | 24. 8mm x 12mm Flange (2) |
| 8. VCMB391 (1) | 25. 89254-007 (1) |
| 9. VCMB392 (1) | 26. 10mm x 55mm (2) |
| 10. VCMB393 (1) | 27. 89203-007 (1) |
| 11. 10mm LW (3) | 28. FSK39A Fan Spacer (1) |
| 12. 10mm x 90mm (2) | 29. 5060538 Dayco (1) |
| 13. 10mm x 50mm (1) | 30. 10mm x 30mm (2) |
| 14. 10mm 20mm Flange Bolt (4) | 31. 10mm x 40mm (2) |
| 15. 10mm x 120mm (3) | 32. 10mm Flange Nut (2) |
| 16. 1/4 LW (1) | 33. 1255-0090 Slide Bushing (2) |
| 17. 1/4 x 3/4 (1) | |

MODIFICATIONS SHEET

