



CW MILL EQUIPMENT CO., INC.
P.O. Box 246 • Sabetha, Kansas 66534
(785) 284-3454 • FAX (785) 284-3601

CMK 48A-I6 Belt
2001-06 CHEVY
2500HD & 3500 Silverado
8.1, V-8
W-WO/AC

INSTALLATION NOTES

1. Disconnect the negative battery cable. Remove the air intake duct. Removing the fan shroud and fan is not necessary, but does make installation easier. Fan nut has right hand threads. Remove the heater hose standoff from the front of the passenger side cylinder head. Remove the O.E.M. belt and tensioner, they will not be reused.
2. Install pump (13) into the back side of bracket (1) with bolts, nuts, & lockwashers (10, 11, 12). Install the coil and clutch as per manufacturers instructions. Install the pump and bracket assembly onto the engine at locations A, B, & C with bolts (8) & LW's (9). Torque to 35 ft. lbs. Install the grooved idler (5) & spacer (4) onto the bracket at location D with bolt (7) and flat washer (6). Install the tensioner (2) with bolt (3) and torque to 25-30 ft. lbs.
3. Install the new belt and route it according to the diagram. It is easiest to install the belt over the O.E.M. idler last. Install the fan and fan shroud if removed.
4. Using a hacksaw cut the resonator from the air duct as close to the main tube as possible. Cut out a piece of plastic from the resonator approximately one-half inch larger in diameter than the hole in the duct. Attach that piece of plastic to the air duct with RTV sealer or its equivalent. Small screws or rivets may be used to hold the piece in place. Once the sealer has set up, wrap the duct with several layers of quality black pliable tape. Install the duct onto the vehicle and check to make sure it clears the pump.
5. Reconnect the battery cable. Run the engine and check for proper belt tracking.

CAUTION: Check all engine compartment vacuum hoses and electrical wiring that may have been disturbed or re-routed during kit installation to be sure that hoses are not kinked, do not touch any high temperature item, and do not interfere with any linkage components.

CMK 48A-I6 Belt
2001-06 Chevy
2500 HD & 3500 Silverado
8.1 V-8
W-WO/AC

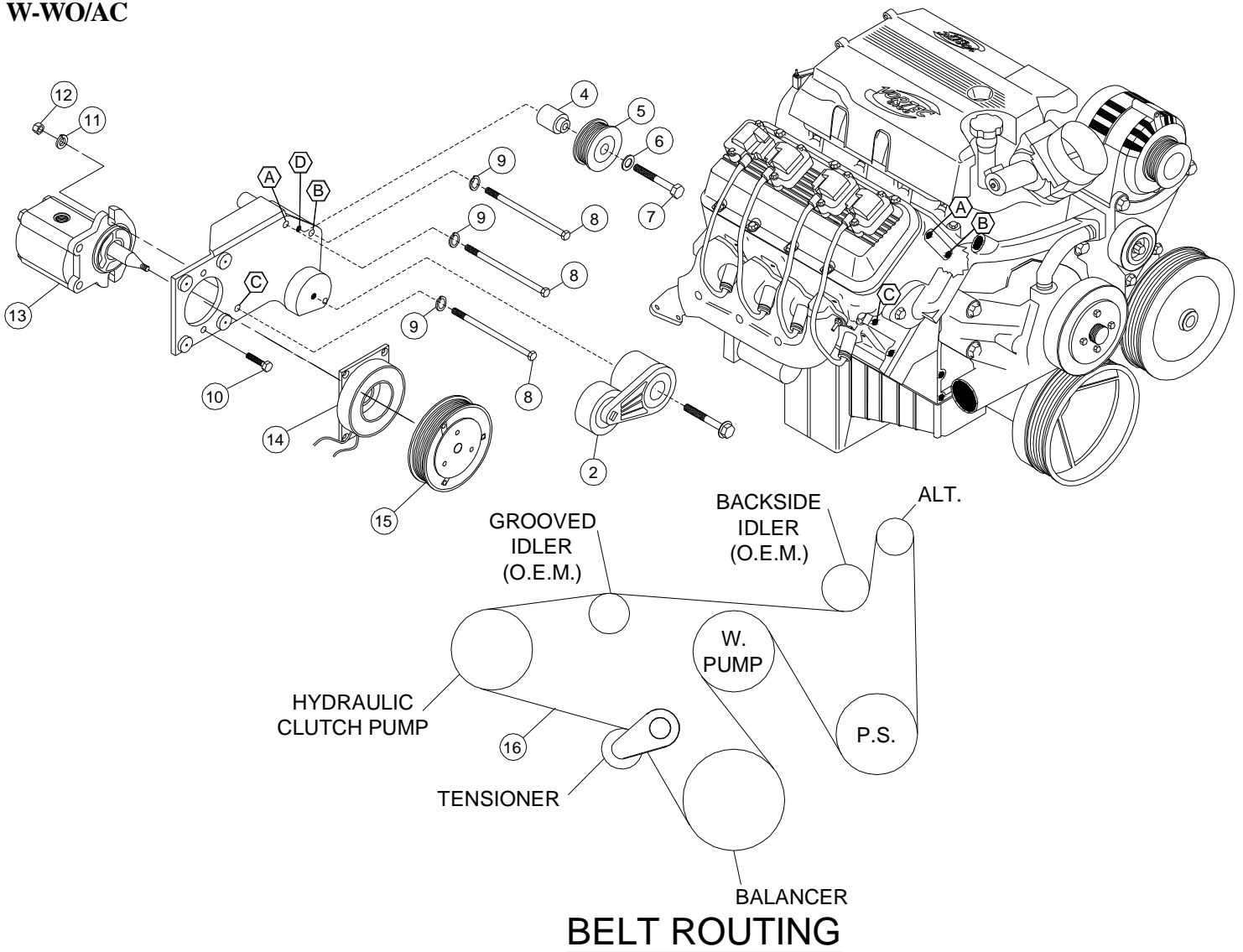

BELT ROUTING

PARTS LIST

- | | |
|--------------------------------|-------------------------------------|
| 1. CMB 48AI6 (1) | 12. 3/8 Nut (2) |
| 2. 89203 TIPCS (1) | 13. Clutch Pump (1) Sold Separately |
| 3. 10mm X 60mm Flange bolt (1) | 14. Coil (1) Sold Separately |
| 4. CMB 48A-1 | 15. Clutch (1) Sold Separately |
| 5. 89009 Dayco (1) | 16. 5061150 Dayco Belt (1) |
| 6. 10mm Flat Washer (1) | |
| 7. 10mm X 60mm (1) | |
| 8. 10mm X 110mm (3) | |
| 9. 10mm LW (3) | |
| 10. 3/8 X 1/2 (2) | |
| 11. 3/8 LW (2) | |