



CW MILL EQUIPMENT CO., INC.
P.O. Box 246 • Sabetha, Kansas 66534
(785) 284-3454 • FAX (785) 284-3601

CMK 54 -2 Belt
2001-09 CHEVY
C6500 & C7500 Trucks
8.1, V-8
W-WO/AC, WO/Compressor

NOTE: MUST USE SIDE PORTED PUMP.

INSTALLATION NOTES

1. Disconnect negative battery terminal. Remove the radiator overflow tank. Remove the OEM serpentine belt and idler from the powersteering bracket. Remove the two bolts holding the powersteering pump to its bracket. Remove the bolts at locations “A through F”. Location “D” is the upper bolt in the left hand motor mount.
2. Install the clutch pump bracket onto the powersteering bracket with bolts and lockwashers (11 & 12) at locations “A,B, & C”. **Do Not Tighten.** Reinstall the P/S hose brace at locations “E & F” with bolts and lockwasher (10 & 12). NOTE: The powersteering hose brace has to go on the outside of the pump bracket and will need to be slightly rebent. Tighten bolts evenly and securely. Install brace (5) onto the main bracket (4) using bolts, lockwashers and flatwashers (8,12 & 13). **Do Not Tighten.** Install the OEM motormount bolt at location “D” with spacer (7). Tighten bolts evenly and securely.
3. Install the pump drive pulley (1) onto the damper using bolts and lockwashers (2 & 3). Install the two bolts back into the powersteering pump and reinstall the OEM idler. Install the OEM belt back to its original routing.
4. Remove the clamps holding the engine oil cooler lines at the radiator and the standoff at the engine. Drill the existing hole in the crossmember to 11/32, and secure the hoses to the crossmember with the hose bracket provided in the kit. Install the clutch pump to the pump plate and align it with drive pulley. Install the pump belts and tension them with the jacknut. Secure the four pump plate bolts. Replace the radiator overflow tank and reconnect the battery cable.

CAUTION: Check all engine compartment hoses and electrical wiring that may have been disturbed or re-routed during kit installation to be sure that hoses are not kinked, that they do not touch any high temperature items, and that they do not interfere with any linkage components.

CMK 54 -2 Belt
2001-09 Chevy
C6500 & C7500 Truck
8.1 V-8
W-WO/AC, WO/Compressor

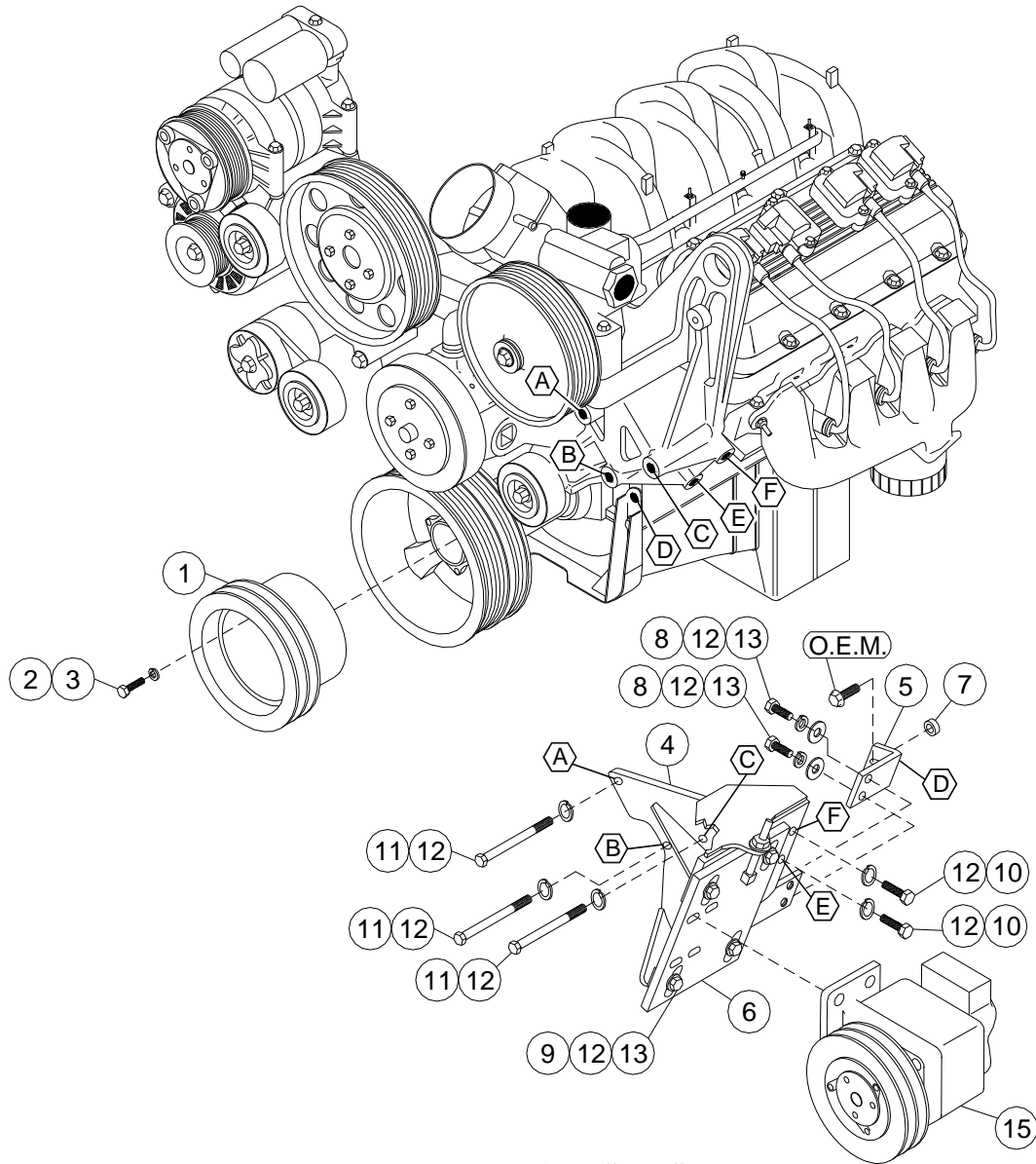

PARTS LIST

- | | |
|--------------------------|-------------------------------------|
| 1. CPC 542A (1) | 13. 10mm FW (6) |
| 2. 8mm x 30mm 10.9 (6) | 14. Belts (Not Shown) (2) |
| 3. 8mm LW (6) | Goodyear A43F |
| 4. CMB 540 (1) | #2 A42F, #4 A42F |
| 5. CMB 541 (1) | 15. Clutch Pump Assy. (1) |
| 6. CMP 54 (0-4) (1) | (Sold Separately) |
| 7. SP88-0.25 (1) | <u>Hose Mount Assy. (Not Shown)</u> |
| 8. 10mm x 20mm 1.5 (2) | 16. 8mm x 60mm 10.9 (1) |
| 9. 10mm x 25mm 1.5 (4) | 17. 8mm LW (1) |
| 10. 10mm x 35mm 1.5 (2) | 18. 8mm Nut (1) |
| 11. 10mm x 130mm 1.5 (3) | 19. SP50-1.25 (1) |
| 12. 10mm LW (11) | 20. CMB 542 (1) |

Note: With 7" Clutch #2 A44F, #4 A43F.