



CW MILL EQUIPMENT CO., INC.
P.O. Box 246 • Sabetha, Kansas 66534
(785) 284-3454 • FAX (785) 284-3601

CMK 73 -2MOD

1990-2002 CHEVY

CAT 3116,3126

C-65,75 Kodiak, Topkick

W-WO/AC, W-WO Air brakes

INSTALLATION NOTES

1. Disconnect negative battery cable. Remove the engine cooling fan from the fan idler and let it rest inside the fan shroud. Fan nut is left hand threads. Care should be taken not to damage the cooling fins on the radiator. Remove the fan belt. Remove the O.E.M. fan idler pulley and replace it with the pulley (1) from the kit. Reuse O.E.M. pulley bolts. Install the O.E.M. serpentine belt.
2. Remove any bolts, straps or standoff that might be bolted to the front side of the engine at location "A". Install bracket (2) to that location and secure it with bolts (4) and lockwashers (5). Install the pump (11) onto the pump plate (3) loosely with the pump bolts provided in the kit. Install the pump and plate assembly onto the main bracket with bolts (6 & 7), lockwashers (8), flatwasher (9) and nut (10). Align the clutch pulley with the drive pulley, then secure the pump to the plate. Install the pump belts and tension properly.
3. If any hose, wires, etc. were removed from location "A", find the best suitable place to relocate them out of the way. Replace the cooling fan and connect the battery cable. Make sure there are no wires or hoses that may come in contact with any moving parts on the truck.

CMK 73 -2MOD

1990-2002 Chevy C-65,75 Kodiak

CAT 3126,3116 W-WO/AC, W-WO Air brakes

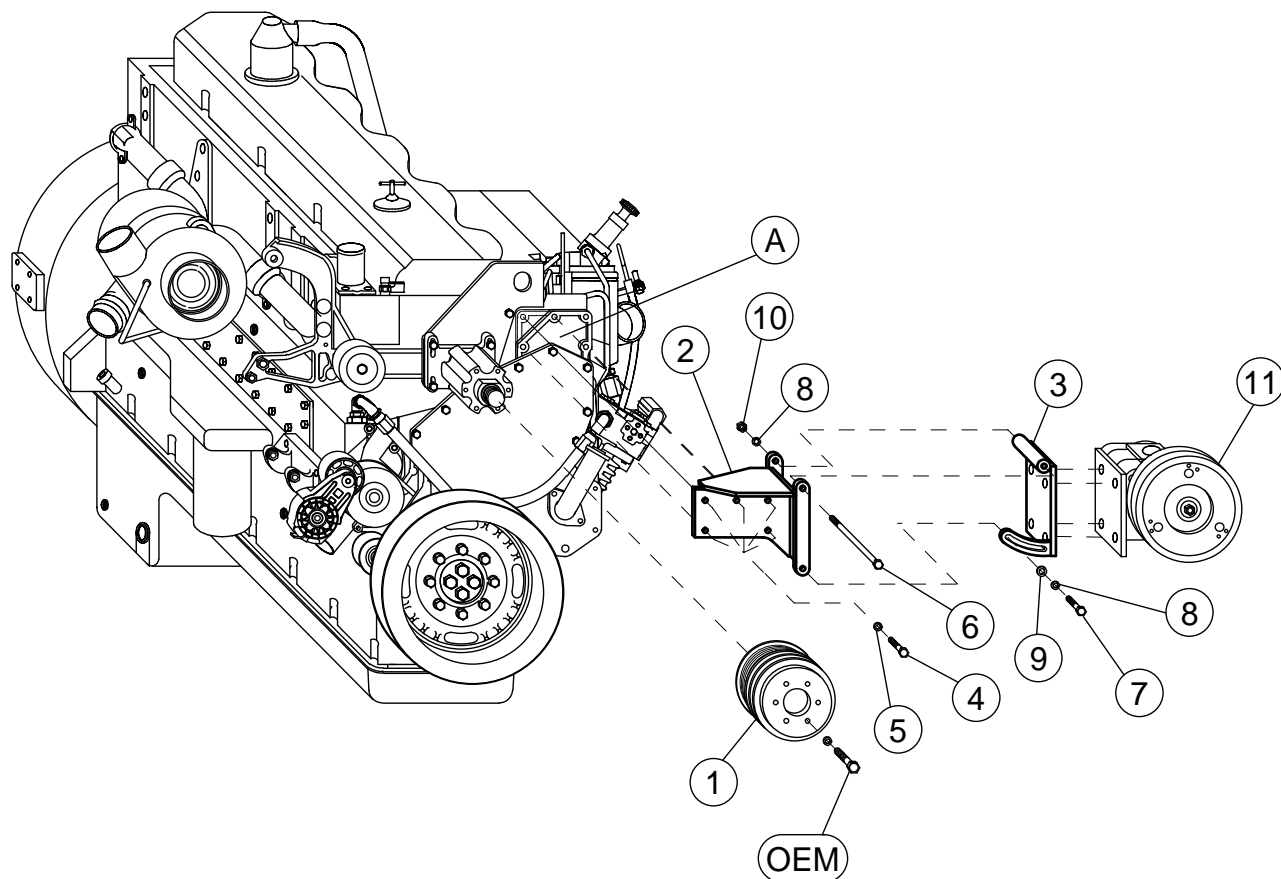

PARTS LIST

1. CPC 712 (1)
2. CMB 730 (1)
3. CMP 73(0-4) (1)
4. 10mm x 55mm 1.5 10.9 (5)
5. 10mm LW (5)
6. 3/8 x 5 NC (1)
7. 3/8 x 1-1/4 NC (1)
8. 3/8 LW (2)
9. 3/8 FW (1)
10. 3/8 NC (1)
11. A56F (2) (Not Shown) (#2 A55F,#4 A54F)
12. Clutch Pump Assembly (1) (Sold Separately)

NOTE: With 7" Clutch #2 A56F, #4 A56F.