



CWMILL EQUIPMENT CO., INC.
P.O. Box 246 • Sabetha, Kansas 66534
(785) 284-3454 • FAX (785) 284-3601

IMK 48 L3S-I8 Belt

2002-04 International
4300-4400
DT466
W-/AC

INSTALLATION NOTES

1. Disconnect the negative battery cable(s). Drain the engine coolant, and remove the passenger side inner fenderwell. Remove the A/C belt, the accessory drive belt and accessory drive tensioner. Remove the alternator and alternator mounting bracket.
2. Disconnect the heater hose from the 45° fitting at location "H". Remove the fitting. Apply sealant to the male threads of the 90° street fitting, and install it into the head at location "H" with the female opening pointed straight up. Apply sealant to the threads on hose fitting and install it in the 90° fitting. Reconnect the heater hose.
NOTE: Shorten the heater hose as necessary.
3. Using bolts (3), lockwashers (4) and nuts (5) at locations "A, B & D" and bolt (6) with lockwasher (7) and nut (8) at location "C", install the alternator bracket (1) and tighten the bolts at all locations. Install the OEM alternator with the OEM bolt and brace (21) at location "F", as shown on diagram, using OEM flatwashers and nut.
DO NOT TIGHTEN. Remove the 12mm bolt at location "G". Install brace (2) with bolt (9) and lockwasher (10) at location "G" and bolt (11) with lockwasher (12) at the top of the alternator. Tighten bolts.
NOTE: It may be necessary to turn the 90° fitting in the aluminum expansion tank so the hose clears the alternator brace (2).
4. Install the alternator onto the bracket using bolt (17), lockwasher (18), nut (19) and spacers (20) on either side of alternator (alteration in spacing maybe required to properly align alternator with pulleys). Install brace with bolt (22) and lockwasher (23) at location "E". Install idler (16) using bolt (13) with lockwasher (14). Use shims (15) to properly align the idler. Install the OEM tensioner back to it's original location. Install the drive belt and route it according to the belt diagram. Replace the A/C belt. Replace the engine coolant. Install the fenderwell and connect the battery(s). Run the engine to make sure the belt tracks properly on the pulleys.

CAUTION: Check all engine compartment hoses and wiring to insure that they are not kinked, touching any high temperature item, or do not interfere with any linkage components.

IMK 48 L3S-I8
2002-04 International
4300-4400
DT466
W/AC

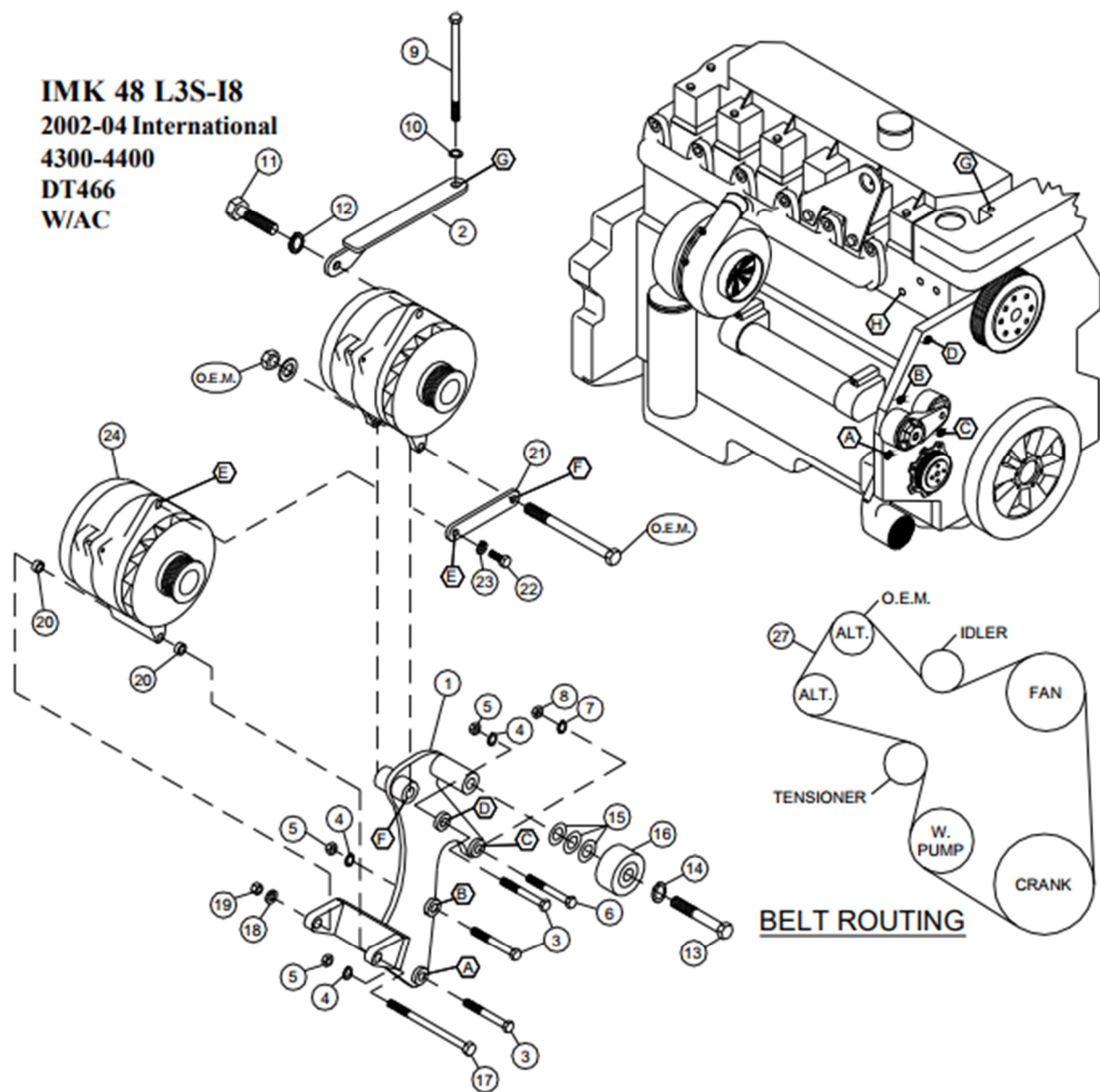

PARTS LIST

- | | |
|--------------------------|----------------------------------|
| 1. IMP 48 L3S (1) | 15. IPW 14 (3) |
| 2. IMB 481 (1) | 16. Dayco 89005 Idler (1) |
| 3. 10mm x 75mm 1.5 (3) | 17. 7/16 x 5 1/2 NC (1) |
| 4. 10mm LW (3) | 18. 7/16 LW (1) |
| 5. 10mm 1.5 Nut (3) | 19. 7/16 Nut (1) |
| 6. 8mm x 70mm 1.25 (1) | 20. SP88-0.250 Spacer (2) |
| 7. 8mm LW (1) | 21. IMB 482 L3S Brace (1) |
| 8. 8mm 1.25 Nut (1) | 22. 3/8 x 1 NC (1) |
| 9. 12mm x 180mm 1.75 (1) | 23. 3/8 LW (1) |
| 10. 12mm LW (1) | 24. Alternator (Sold Separately) |
| 11. 1/2 x 1 1/2 NC (1) | 25. 3400-8 90° Fitting (1) |
| 12. 1/2 LW (1) | 26. 4404-12-8 Hose Barb (1) |
| 13. 5/8 x 2 1/2 NC (1) | 27. Gates K080830 Belt |
| 14. 5/8 LW (1) | |