

## PARTS LIST

- |                          |                         |
|--------------------------|-------------------------|
| 1. NMP51L3S-6 (1)        | 13. 6X40MM FLG BOLT (1) |
| 2. 89254-007 (1)         | 14. 6X35MM FLG BOLT (6) |
| 3. NPC516 (1)            | 15. 6X25MM FLG BOLT (2) |
| 4. 10X60MM FLG BOLT (2)  | 16. 8X25MM FLG BOLT (2) |
| 5. 89051 (1)             | 17. 8MM FLG NUT (1)     |
| 6. 89007 (1)             | 18. #28 HD WIRE CLAMP   |
| 7. NMB51-2 (2)           | 19. NMB51-1 (1)         |
| 8. 5060790 BELT          | 20. L3SB3 (1)           |
| 9. 10X80MM FLG BOLT (1)  | 21. 7/16X4 BOLT (1)     |
| 10. 10X55MM FLG BOLT (1) | 22. 3/8X1.25 BOLT (2)   |
| 11. 10X30MM FLG BOLT (3) | 23. 3/8 FLT WSHR (1)    |
| 12. 8X40MM FLG BOLT (1)  | 24. 3/8 LOCK WSHR (2)   |

1. Be sure to read and understand all available information including but not limited to instructions, warnings, sale terms, and warranties for the vehicle and all system components prior to attempting installation.
2. Remove bottom portion of fan shroud. Remove belt. Disconnect fan wire and remove fan.
3. Remove power steering reservoir and bracket. Cut bracket as shown below and discard the lower section. Remove the zip tie from the "Y" in the wiring harness that is attached to the timing cover. It retains the wiring that goes to the power steering line.

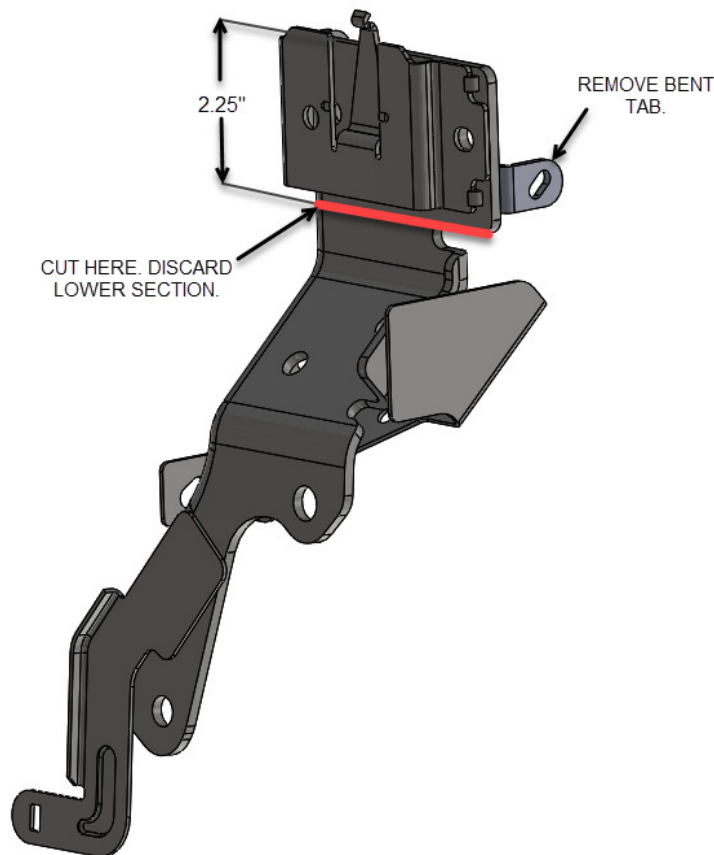

4. Install bracket (1) onto engine using bolts (9), (11), (12), and (13). Use caution not to damage wiring harness located between the bracket and timing cover. The wire to the power steering pressure sensor must be routed behind the bracket and emerge in front of bolt (11).
5. Install pulley (3) with 6x35mm bolts (14)
6. Reinstall fan, fan wire, OEM belt, and lower shroud.

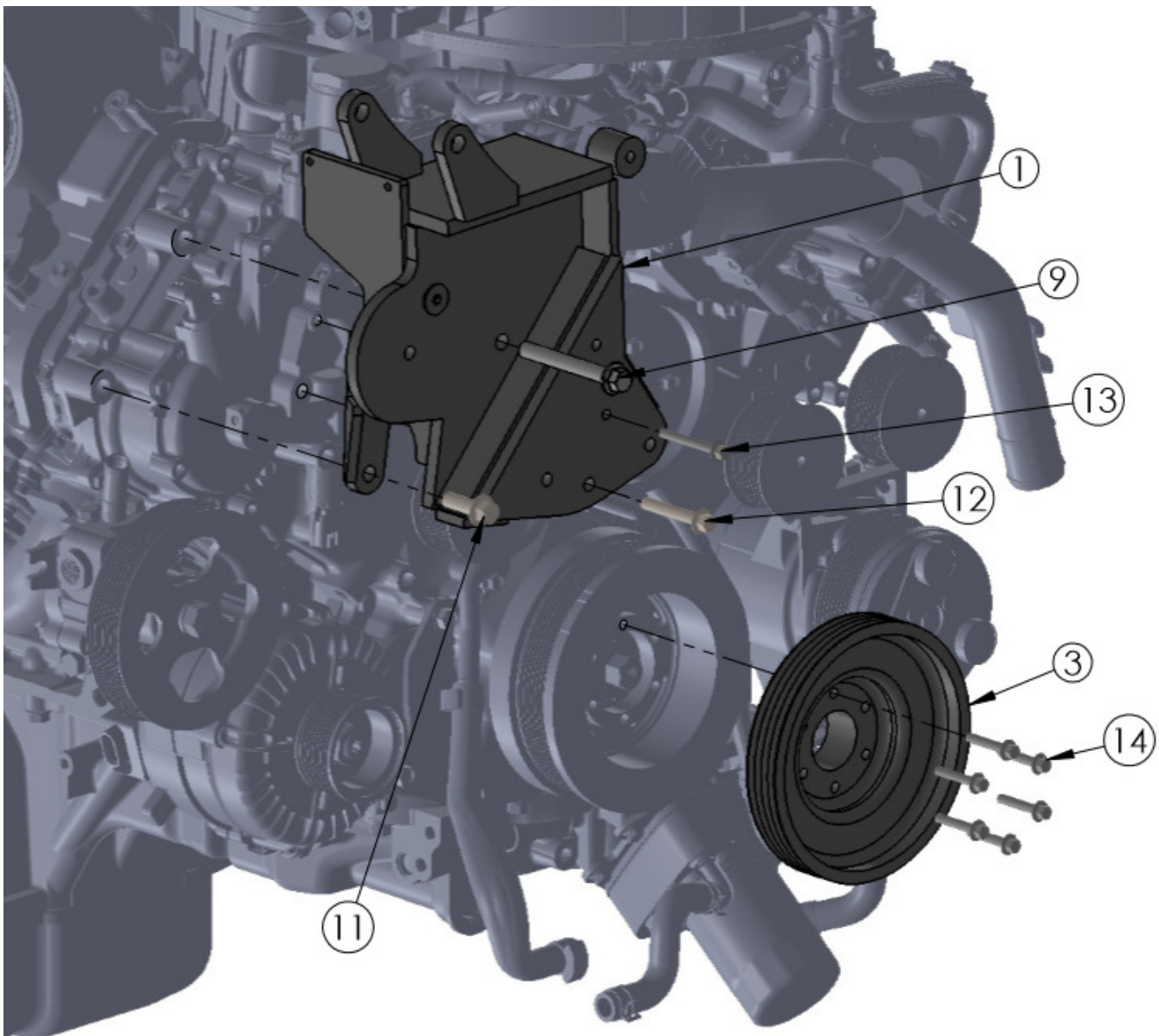

7. Install idlers (5) at location A and (6) at location B with bushings (7) and 10x60mm bolts (4). Install tensioner (2) with 10x55mm bolt (10). Attach standoff (19) with 8x25mm bolt (16). Install modified OEM power steering reservoir bracket with 8x25mm bolts (15).
8. Install alternator slide (20) using 3/8" lock washer (24) and 3/8x1.25 bolt (22). Attach alternator to bracket with 7/16x4 bolt (21). Attach alternator to slide (20) using 3/8 flat washer (23), 3/8" lock washer (24), and 3/8x1.25 bolt (22).
9. Remove radiator end of upper radiator hose. Cut approximately 3/4" from end of hose and reinstall. Use clamp (18) to secure upper radiator hose to standoff (19) with 8x25mm bolt (16) and 8mm nut (17).

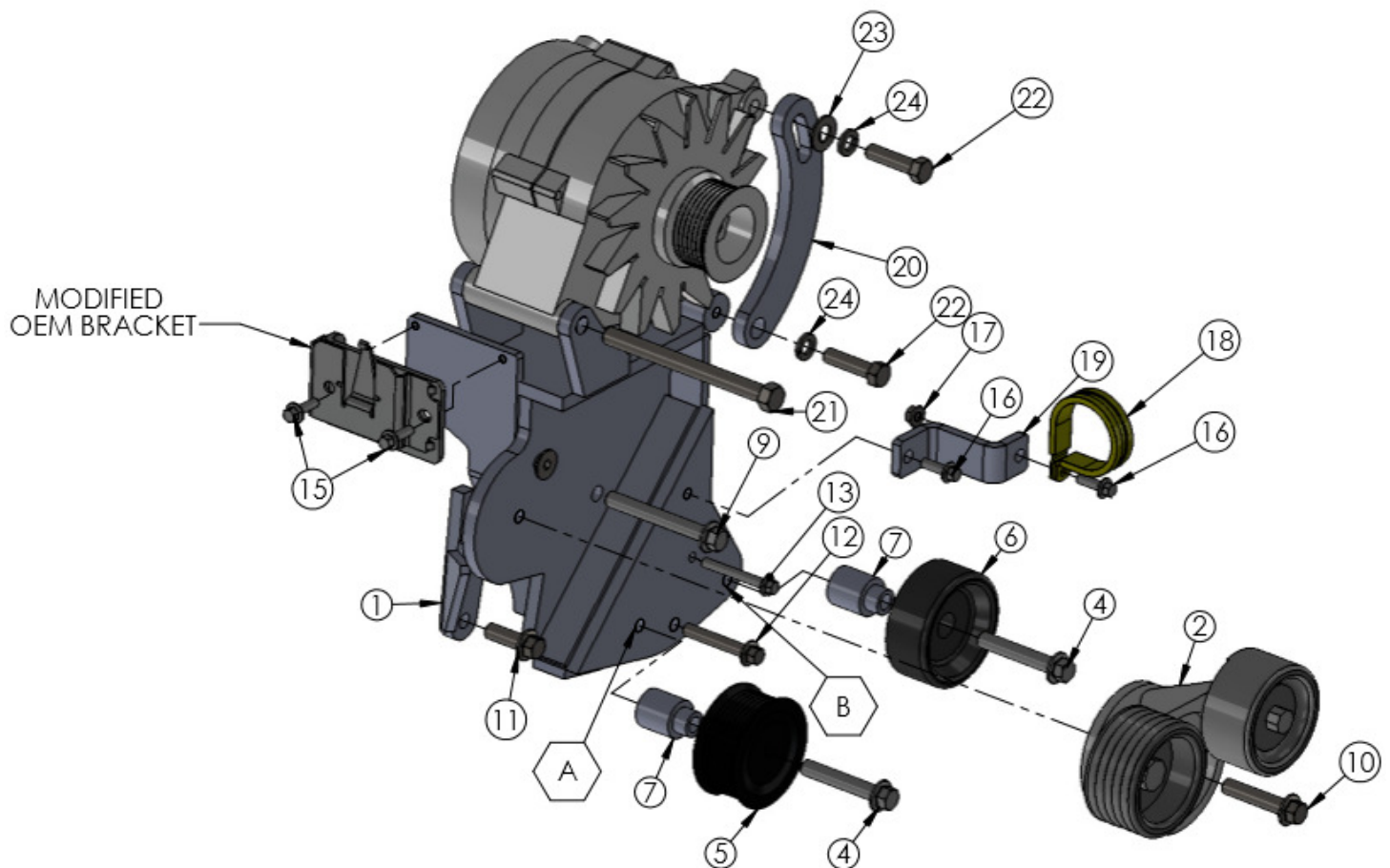

10. Install belt (8) as shown. Make certain all wires and hoses will not come in contact with any hot or moving parts. Run engine and check for proper belt tracking.

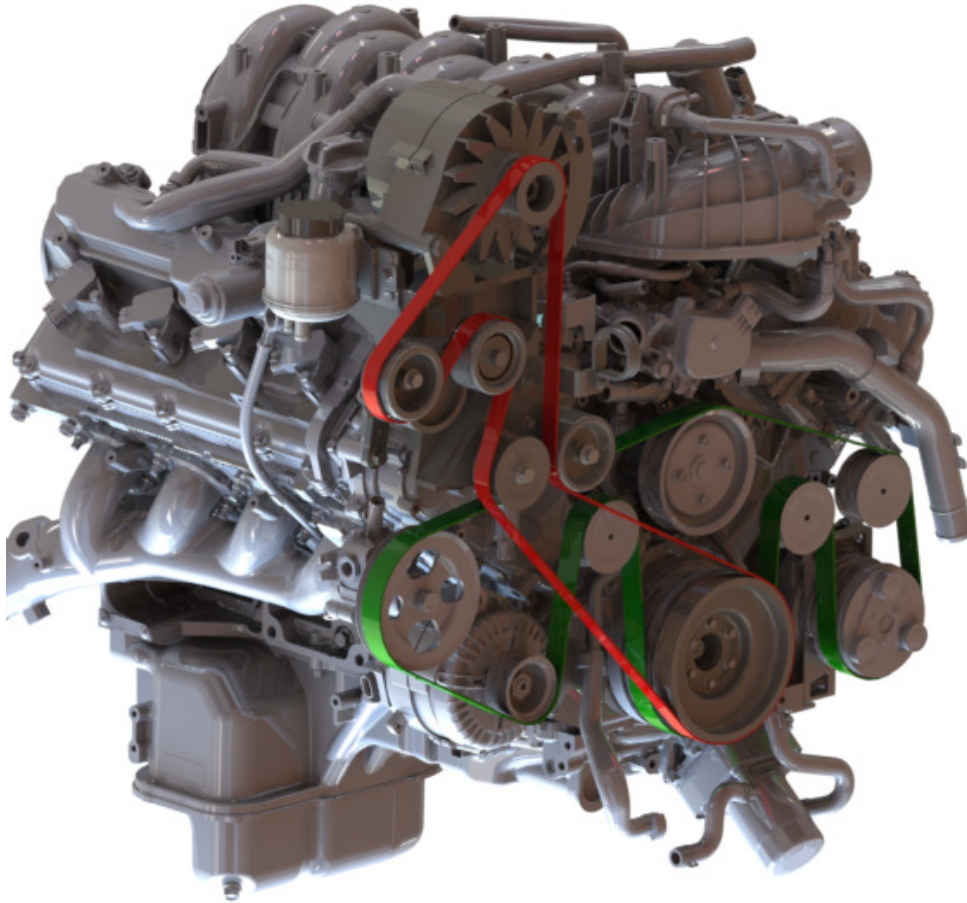

Disclaimer: (1.) Due to the custom nature and variation of all add-on systems of this type, no complete system kits are offered by the manufacturer, and any group of parts marketed as a kit is limited to only the individually defined parts in that specific kit. The system designer's rotating accessory components are not included, offered, or fully known by the manufacturer. In addition to the absence of the rotating accessory system, other potential components such as additional clamps, brackets, wear liners, hardware, or other items that may be required by the system designer must be identified and supplied by the actual system designer. (2.) Due to vehicle manufacturer's assembly tolerances, production changes, and installation variances, it is the buyer's responsibility to insure adequate clearance for all components including space for and safe location of the fan, radiator, all lines, and wires. Check for possible movement, vibration, friction points, heat exposure and/or shifting of any and all components such as hoses, wires, and all other components including those that may otherwise be considered non-moving and/or unaffected by the installation (3.) The buyer is responsible for the entire installation of a mounting kit as the mounting kit as the mounting kit is part of a custom process controlled by the buyer through their whole system design and directed installer as the installer evaluates, locates, routes, aligns, and tightens all components while determining if additional clamps, brackets, wear-liners, or other components may be required, beyond those included in the kit. Any additional items required, beyond those included in the kit, are to be provided at the expense of the buyer. (4.) the buyer is responsible for the development and communication of their whole system installation procedures, safety precautions, application, and use of the engine accessory mounting kit in their system, including efforts to maintain vehicle control and prevent pinch, wear, impact, and/or bum exposure on all hoses, wires, and other parts. (5.) The buyer is responsible for providing trained and experienced installation decision making with technical know-how to apply professional judgment that specifically applies to each individual installation. The buyers chosen installers must be qualified and experienced technicians that are familiar with the vehicle and accessory being mounted as well as the buyer's whole system design and installation procedures associated with the kit. (6.) The buyer is responsible for determining and achieving compliance to all regulatory issues that apply to the use of all products. (7.) The manufacturer reserves the right to make changes and/or improvements to any product at any time with or without notice.