



CWMILLEQUIPMENT CO., INC.  
P.O. Box 246 • Sabetha, Kansas 66534  
(785) 284-3454 • FAX (785) 284-3601

**CMK 24 -2 Belts**  
**1987-89 Chevy**  
**C & K 1500,2500**  
**4.3 V-6, W-WO/AC**

## INSTALLATION NOTES

1. Disconnect battery terminal. Loosen or remove serpentine belt. Remove top half of fan shroud. Mark fan to water pump pulley for proper re-installation, then remove fan.
2. Remove bolts and washers from pulley on crankshaft. Install drive pulley (1) with provided bolts and lockwashers. **CAUTION:** Be sure to use bolts with the same thread as O.E.M. bolts removed.
3. Remove top water pump bolt at location "A", two bolts at locations "B & C", and nut at location "D".
4. Install mounting bracket (10) using provided spacers (12 & 13), bolts (15), and O.E.M. nut (21). **NOTE:** A power steering hose may be looped up in location of mounting bracket (10). If so, carefully re-route hose to gain clearance for bracket. It may be necessary to remove hose and re-install around other power steering lines.
5. Remove small guard which protects small vacuum line from serpentine belt. Remove bottom half of bracket as shown. Re-install and secure vacuum line to remaining top portion of bracket with tape or nylon wire tie.
6. Mount clutch pump (23) to pump plate. Make sure clutch pulley is in line with drive pulley (1). Tighten pump bolts securely. Install pump drive belts (22), adjust pump plate (11) for proper belt tension. Tighten bolts (16 & 17).
7. Install fan with spacer (6) aligning marks from step 1, and fan shroud. Tension serpentine belt and connect battery terminal.
8. **CAUTION:** Check all engine compartment vacuum and power steering hoses that may have been disturbed or re-routed during kit installation to be sure hoses are not kinked, that they do not touch any high temperature item, and that they do not interfere with any linkage components.

**NOTE:** This kit is designed to operate successfully with the standard fan supplied by the manufacturer of your truck. Due to O.E.M. assembly tolerances and change, visually make certain that there is adequate clearance between fan and drive pulley. It may be necessary to use a different fan spacer for proper clearance.

**CMK 24 -2 Belt**  
**1987-89 Chevy**  
**C&K 1500,2500**  
**4.3 V-6, W-WO/AC**

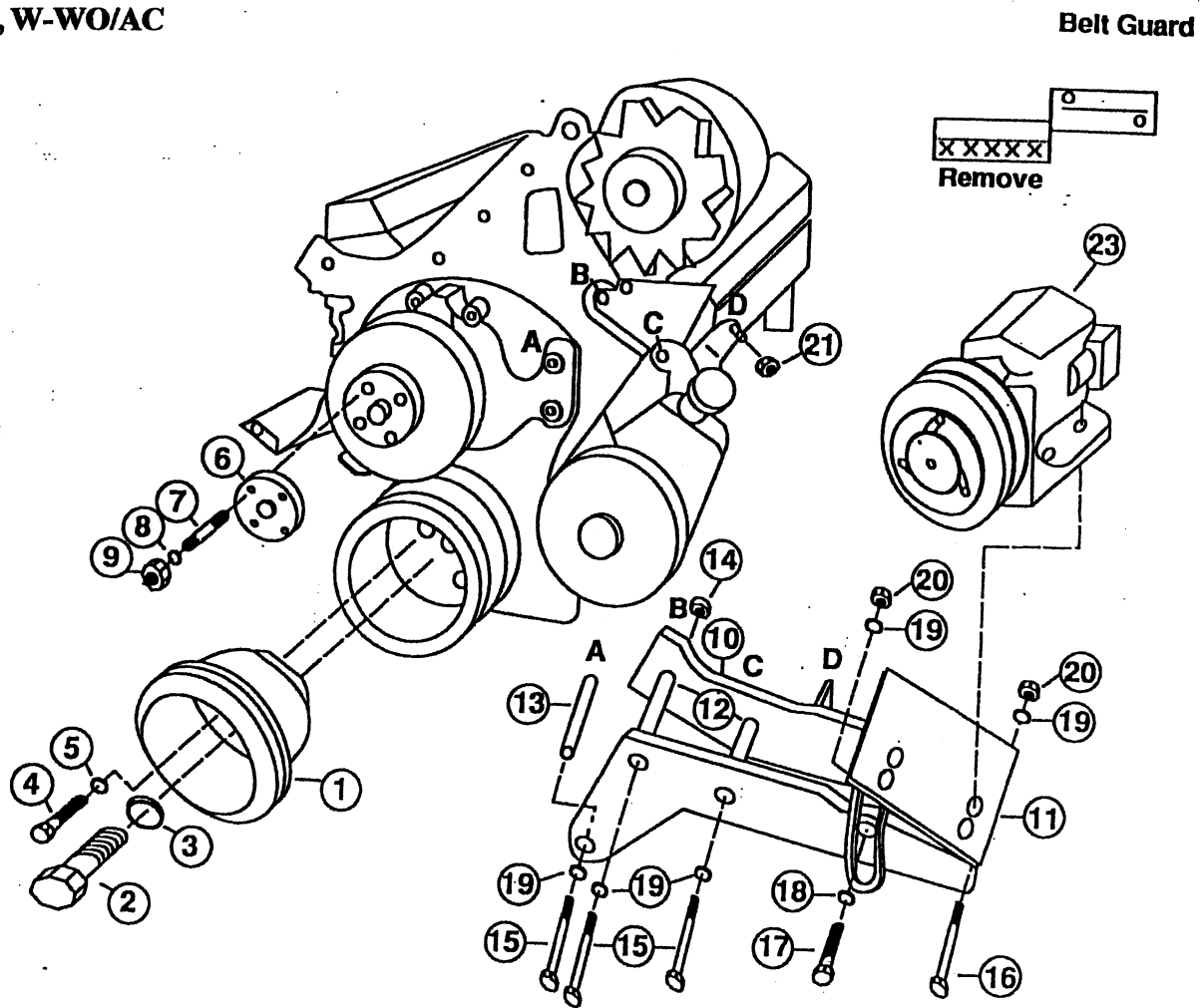

**PARTS LIST**

- |                                |  |
|--------------------------------|--|
| 1. CPC 312 (1)                 | 13. SP88-2.312 (1)                         |
| 2. 7/16 X 3 NF GR.8 (1)        | 14. SP64-0.250 (1)                         |
| 3. 7/16 LW (1)                 | 15. 3/8 X 5-NC (3)                         |
| 4. 3/8 X 1-1/2 NF,NC GR. 8 (3) | 16. 3/8 X 4-1/2 NC (1)                     |
| 5. 3/8 LW (3)                  | 17. 3/8 X 1-1/2 NC (1)                     |
| 6. FSO 505 (1)                 | 18. 3/8 FW (1)                             |
| 7. 8mm X 45mm 1.25 ST (4)      | 19. 3/8 LW (5)                             |
| 8. 8mm LW (4)                  | 20. 3/8 NC (2)                             |
| 9. 8mm 1.25 nuts (4)           | 21. O.E.M.                                 |
| 10. CMB 340 (1)                | 22. AF59 Goodyear (2) (Not Shown)(#4 A57F) |
| 11. CMP 34(0-4) (1)            | 23. Clutch Pump Assembly (1)               |
| 12. SP88-2.875 (2)             | (Sold Separately)                          |

**NOTE:** Use spacer (14) when there is no alternator brace at location "B".

**NOTE:** Brace at location "D" goes over tab on bracket.

**NOTE:** With 7" clutch A59F.