



VFLMK23SD508-6

3.0L V6 Diesel

2007-18 Freightliner 2500-3500 Sprinter
2007-18 Mercedes 2500-3500 Sprinter
2007-2009 Dodge Van 2500-3500 Sprinter

FOR USE W-WO AC

WRENCHES ARE AVAILABLE AND SUGGESTED FOR REMOVAL AND
RETORQUING HARMONIC BALANCER BOLT, PART # VFL23WR-1 &
VFL23WR-2. THESE ARE SOLD SEPARATELY.

INSTALLATION NOTES

1. Remove air cleaner assembly. Remove the fan and fan shroud. Remove harmonic balancer bolt using wrench (pn. VFLWR-1 sold separately)(bolt has right hand threads).
2. Install pulley adapter(1) using bolt(3), O.E.M. spacer, and set screws(4). Install pulley (2) onto adapter (1) using bolts (5). Torque harmonic balancer bolt to 280 ft/lbs using wrench (pn. VFLWR-2 sold separately). Cross torque set screws at 10 in/lbs., 30 in/lbs., 60 in/lbs., 90 in/lbs., 120 in/lbs. Mild-grade of Loctite is advisable to use on set screws. Install studs (9) with red Loctite and torque to 5 ft/lbs.. Install main bracket (6) with nuts (16) at locations "A" and "B". Check for gap at locations "C" and "D" with feelers gauge. Remove bracket (6) and install appropriate shims (22,23) on studs at locations "C" and "D". Reinstall main bracket (6) using nuts (16) and brace (24). Install front brace (7) using bolts(11,12), lock washer(10), and spacer(8). Install belt tensioner(13) using bolt(14).
3. Install A.C. compressor using slide bushings(20), bolts(17,18), and nuts(19). Install new drive belt(15). Install fan spacer(21), fan, and fan shroud. Fan shroud will need to be trimmed for clearance with the drive belt and tensioner. Run the engine and check for proper belt alignment, tracking, and clearances.

VFLMK 23SD508-6

3.0L V-6 Diesel - FOR USE W-WO AC

2007-18 Freightliner 2500-3500 Sprinter

2007-18 Mercedes 2500-3500 Sprinter

2007-2009 Dodge Van 2500-3500 Sprinter

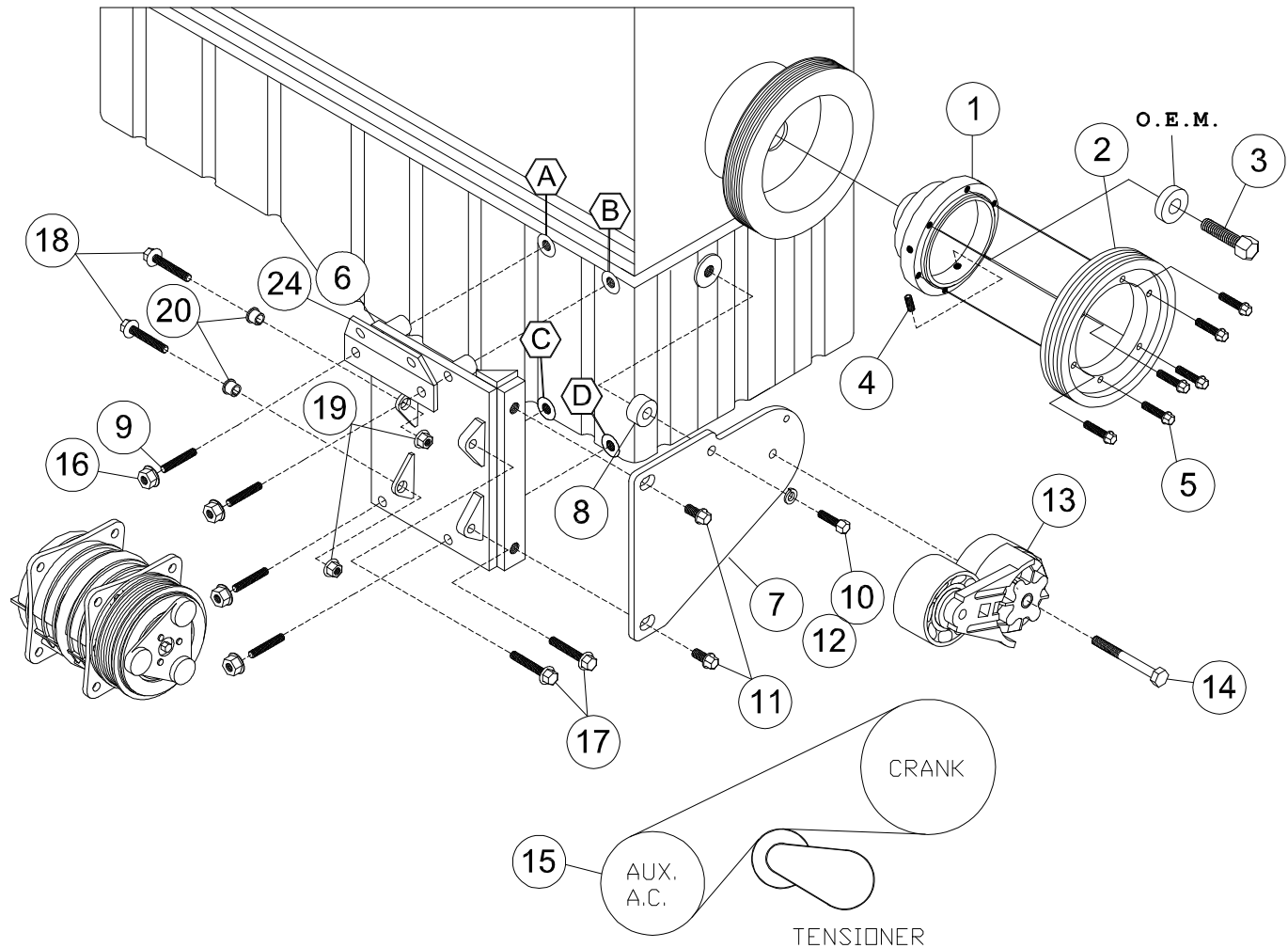

PARTS LIST

- | | | |
|--------------------------------|----------------------------------|---------------------------------|
| 1. VFLPA 23 (1) | 9. 8mm x 80mm Stud (4) | 17. 10mm x 30mm Flange Bolt (2) |
| 2. VFLPC 236 (1) | 10. 8mm LW (1) | 18. 10mm x 40mm Flange Bolt (2) |
| 3. 18mm x 110mm x 1.5 Bolt (1) | 11. 10mm x 20mm Flanged Bolt (2) | 19. 10mm x 1.5 Flanged Nut (2) |
| 4. 8mm x 20mm set screw (3) | 12. 8mm 35mm Bolt (1) | 20. 1255-0090 Slide Bushing (2) |
| 5. 8mm x 30mm Flange Bolt (6) | 13. 89200D Tensioner (1) | 21. FSK 38 Fan Spacer (1) |
| 6. VFLMP 23SD508 (1) | 14. 10mm x 75mm Bolt (1) | 22. .005" Shim (2) |
| 7. VFLMB 231 (1) | 15. 5060470 Dayco Belt (1) | 23. .010" Shim (2) |
| 8. SP125-0.500 (1) | 16. 8mm Flange Nut (4) | 24. VFLMB232 (1) |

WRENCHES ARE AVAILABLE AND SUGGESTED FOR REMOVAL AND RETORQUING HARMONIC BALANCER BOLT, PART # VFL23WR-1 & VFL23WR-2. THESE ARE SOLD SEPARATELY.