

INSTALLATION NOTES

1. Disconnect negative battery cable. Remove the top half of the fan shroud and the fan. (*Fan nut is right hand threads*). It's not necessary to remove the fan and fan shroud, but makes installation easier. Remove the air cleaner duct and the O.E.M. belt.
2. Remove the three bolts holding the O.E.M. alternator bracket to the engine. Install the aux. alternator bracket (1) using those three hole locations on the alternator bracket with three 10mm x 140mm bolts (8) and lock-washers (7). Tighten bolts securely. Install brace (2) using bolt (9) and bushing (3) at the engine, and bolt (10) at the back of bracket (1). Tighten bolts (9) and (10) evenly so the brace does not pull the main bracket when tightened.
3. Install aux. alternator onto the pump bracket using support arm (12), bolts (13,15,16), lock washers (7,14) and nut (17). Install idler (5) with bolt (6) and bushing (4) into the lower tapped hole. Install the belt (11), then load the tensioner and install the other idler into the lowest possible hole it will fit into on the front of the main bracket..
4. Replace the fan and top half of the fan shroud if removed. Replace the air duct.
Connect battery. Run the engine and check for proper belt tracking. Adjust if necessary.
5. If wires from the ECM run close to the belt or clutch, use 1/4 bolts (18), washers (19), spacers (21) and nuts (20) to relocate the ECM to the fan shroud.

NOTE: Check all engine compartment hoses and electrical wiring that may have been disturbed or rerouted during kit installation to be sure that hoses are not kinked, that they do not touch any high temperature items, and that they do not interfere with any linkage components.



CW Mill Equipment Co., Inc.

14 Commerce Drive Sabetha, KS 66534

Phone: (785) 284-3454

Fax: (785) 284-3601

Email: brackets@cwmill.com

MOUNTING KITS

Website: www.cwkits.com

CMK39J180-I6

2011-2013 CHEVY 1500

2011-2019 CHEVY 2500-3500

4.8 5.3 6.0L V8 GAS

For use w/ or w/o AC. Requires 6 Groove Pulley

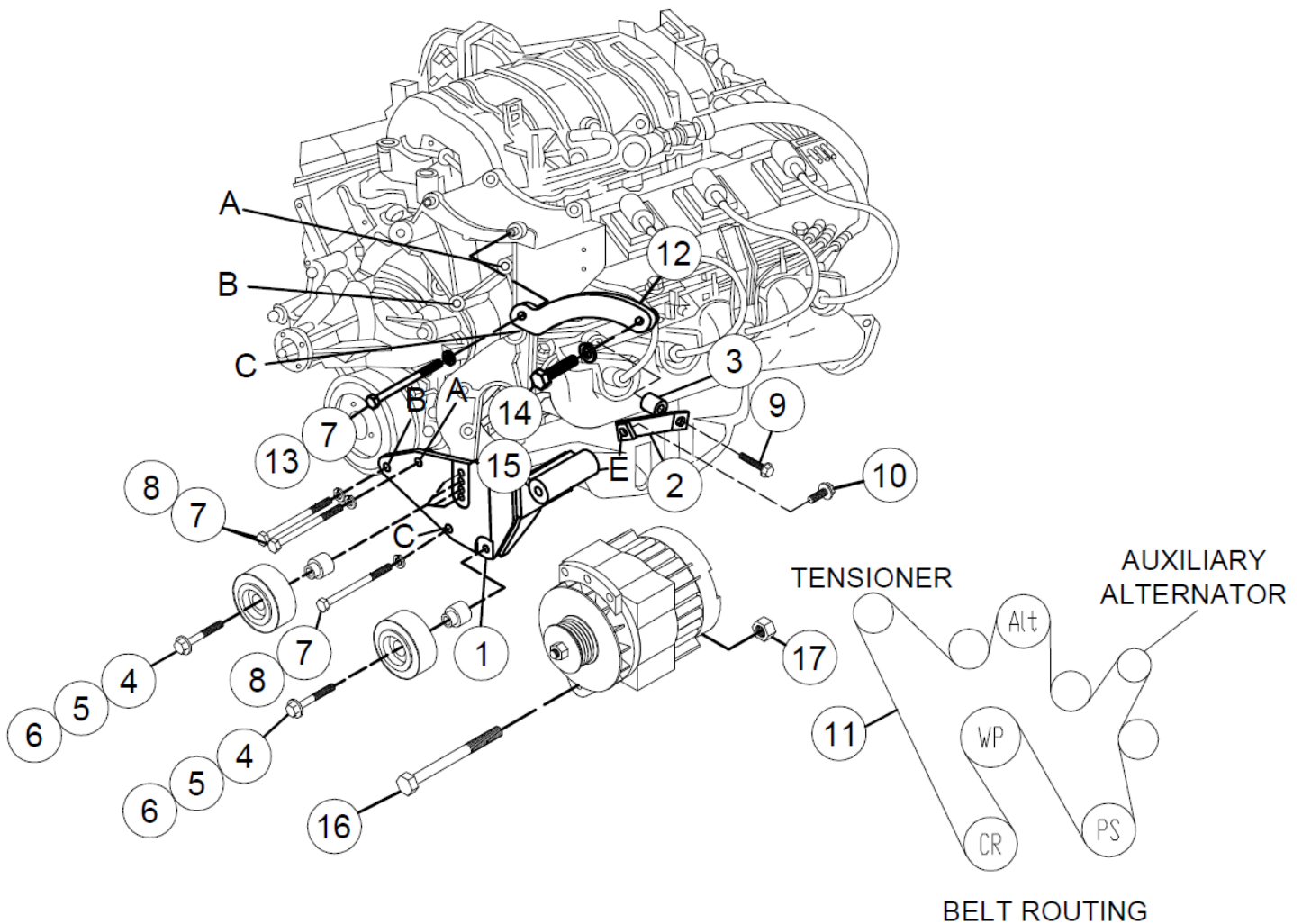

PARTS LIST

- | | |
|---------------------------------------------------|-------------------------|
| 1. CMP39J180 (1) | 12. CMB391J180 (1) |
| 2. CMB391 (1) | 13. 10mm x 100mm (1) |
| 3. SP100-1.200 (1) | 14. 1/2 Lock washer (1) |
| <i>(TIPKSC-39 Includes one of each items 4-6)</i> | 15. 1/2 x 2 Bolt (1) |
| 4. CMB 3867 (2) | 16. 1/2 x 6 Bolt (1) |
| 5. 89007 (2) | 17. 1/2 Nut (1) |
| 6. 10mm x 40mm Flange Bolt (2) | |
| 7. 10mm Lock washer (4) | |
| 8. 10mm x 140mm 1.5 (3) | |
| 9. 10mm x 50mm Flange Bolt (1) | |
| 10. 10mm x 20mm Flange Bolt (1) | |
| 11. Belt Dayco 5061150 (1) | |

ITEMS 18-21 NOT SHOWN

- 18. 1/4 x 2 NC Bolt (4)
- 19. 1/4 Flat washer (4)
- 20. 1/4 Nylock Nut (4)
- 21. SP64-0.500 Spacer (4)