



CW MILL EQUIPMENT CO., INC.
P.O. Box 246 • Sabetha, Kansas 66534
(785) 284-3454 • FAX (785) 284-3601

IMK 51 -I8 Belt

2002-04 International
7000 Series
DT466,DT530,DT570
W-/AC

INSTALLATION NOTES

1. Disconnect the negative battery cable(s). Drain the engine coolant, and remove the passenger side inner fender well. Remove the A/C belt, the accessory drive belt and accessory drive tensioner. Remove the alternator and alternator mounting bracket.
2. Disconnect the heater hose from the 45° fitting at location “E”. Remove the fitting. Apply sealant to the male threads of the 90° street fitting, and install it into the head at location “E” with the female opening pointed straight up. Apply sealant to the threads on hose fitting and install it in the 90° fitting. Reconnect the heater hose.
NOTE: Shorten the heater hose as necessary.
3. Using bolts (3), lockwashers (4) and nuts (5) at locations “A, B & D” and bolt (6) with lockwasher (7) and nut (8) at location “C”, install the pump bracket (1) and tighten the bolts at all locations. Install the alternator with the OEM bolt, flatwashers and nut through the two ears at the bottom of the alternator. **DO NOT TIGHTEN.** Remove the bolt holding the A/C belt tensioner to the A/C bracket. Install bolt (9) at that location and tighten. Install brace (2) with lockwasher (4) and nut (5) to the tensioner bolt on the back side of the A/C bracket. Install bolt (10), lockwasher (11), flatwasher (12), and spacer (13) at the slotted end of brace (2). **DO NOT TIGHTEN.**
4. Install the clutch pump onto the pump bracket using the bolts provided in the kit. Use a straight edge to align the pump with the other pulleys. Install idler (16) using bolt (14) with lockwasher (15). Use shims (17) to properly align the idler. Install the O.E.M. tensioner back to its original location. Install the drive belt and route it according to the belt diagram. Use the alternator to adjust the tensioner for maximum travel. Tighten alternator bolts securely. Replace the A/C belt. Replace the engine coolant. Install the fenderwell and connect the battery(s). Run the engine to make sure the belt tracks properly on the pulleys.

CAUTION: Check all engine compartment hoses and wiring to insure that they are not kinked, touching a high temperature item or that it does not interfere with any linkage components.

IMK 51- I8
2002-04 International
7000 Series
DT466,DT530,DT570
W/A/C

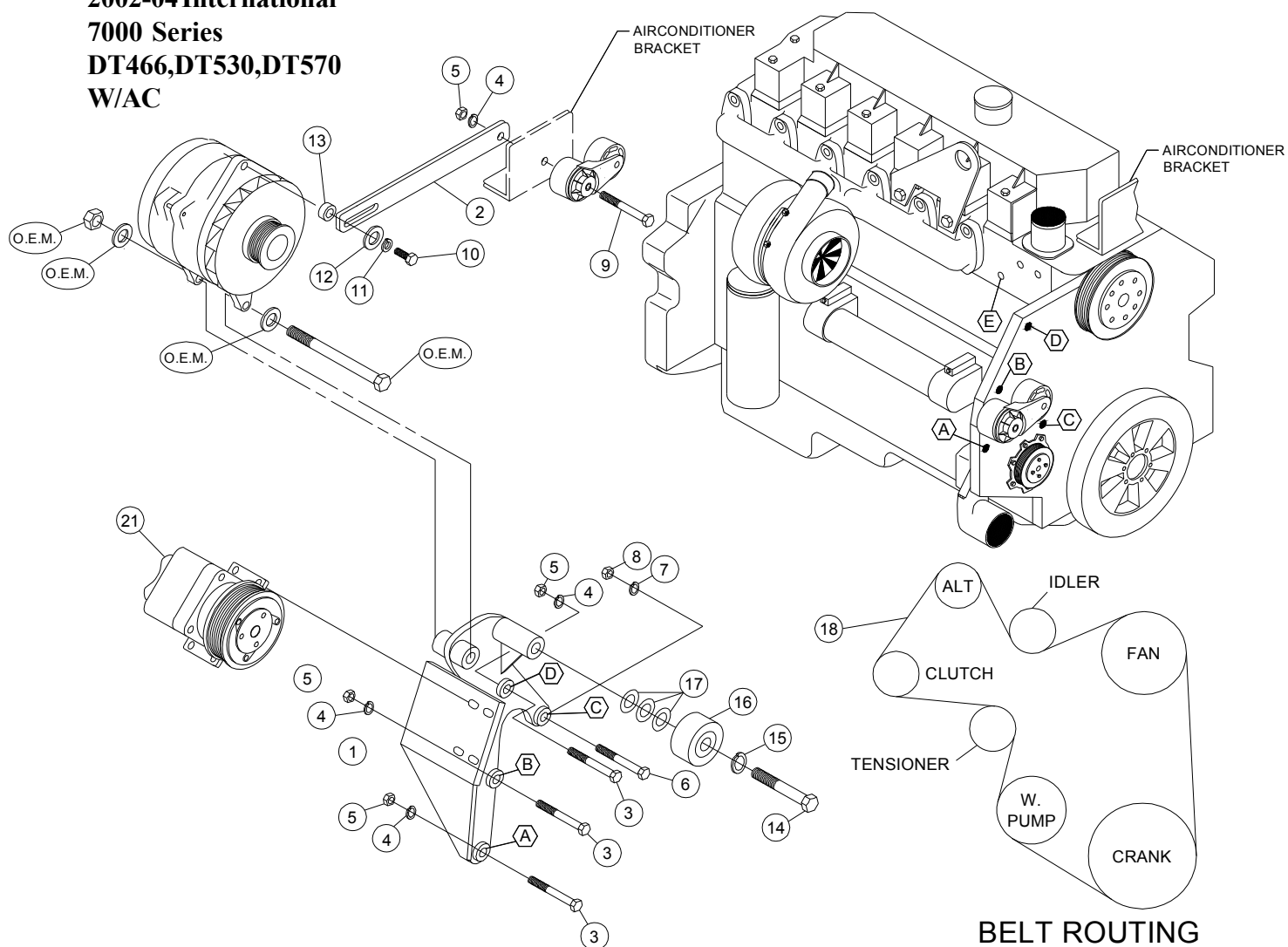

PARTS LIST

- | | |
|--|---|
| 1. IMP 48 (0-4) (1) | 13. 3/8 spacer w/1/2 I.D. (1) |
| 2. IMB 511 (1) | 14. 5/8 x 2 1/2 NC (1) |
| 3. 10mm x 75mm 1.5 (3) | 15. 5/8 LW (1) |
| 4. 10mm LW (4) | 16. Dayco 89005 Idler (1) |
| 5. 10mm 1.5 Nut (4) | 17. IPW14 (3) |
| 6. 8mm x 70mm 1.25 (1) | 18. Belt 5080920 (1) |
| 7. 8mm LW (1) | 19. 3400-8 90° Fitting (1) (Not Shown) |
| 8. 8mm 1.25 Nut (1) | 20. 4404-12-8 Hose Barb (1) (Not Shown) |
| 9. 10mm x 120mm 1.75 (w/50mm of threads) (1) | 21. Clutch Pump (Sold Separately) |
| 10. 1/2 x 1 1/2 NC (1) | |
| 11. 1/2 LW (1) | |
| 12. 1/2 FW (1) | |