



**VCK3992V-I6 Belt**  
**2006-2020 CHEVY**  
**G 1500-3500**  
**4.8, 5.3, 6.0 VORTEC V-8**  
**W-WO/AC**  
**W/O EGR Valve**

---

## INSTALLATION NOTES

---

1. Disconnect the negative battery cable. Remove the air intake duct. Removing the fan shroud and fan is not necessary, but does make installation easier. Fan nut has right hand threads. Remove the O.E.M. belt and tensioner, they will not be reused. Remove oil fill tube and cut off stabilizer bracket flush with tube.
2. Install bracket (1) onto the engine at locations A, B, & C with bolts (3,4) & LW's (2). Torque to 35 ft. lbs. Install the tensioner (9) with bolt (10) and torque to 25-30 ft. lbs. Install alternator (17) with bolts (15) and slide bushings (16). Air conditioner line may need to be bent out of the way. Be sure to leave 2" clearance between alternator and air conditioner line.
3. Remove the factory idler located next to the alternator and in the same location, install idler (12) using bushing (11) and bolt (13).
4. Install the new belt (18) and route it according to the diagram. It is easiest to install the belt over the O.E.M. idler last. Install the fan and fan shroud if removed.
5. Install tube bracket (5) with bolts (6) and lockwashers (8). Bolt transmission dipstick tube to bottom hole of tube bracket using bolt (6), nut (7), and lockwasher (8). Bend the mount for the engine oil dipstick to line up with the top hole on tube bracket. Reinstall oil fill tube and engine oil dipstick, as shown on diagram, using Adel clamp (14), bolt (6), nut (7), and lockwasher (8).
6. Reconnect the battery cable. Run the engine and check for proper belt tracking.

**CAUTION:** Check all engine compartment vacuum hoses and electrical wiring that may have been disturbed or re-routed during kit installation to be sure that hoses are not kinked, do not touch any high temperature item, and do not interfere with any linkage components.

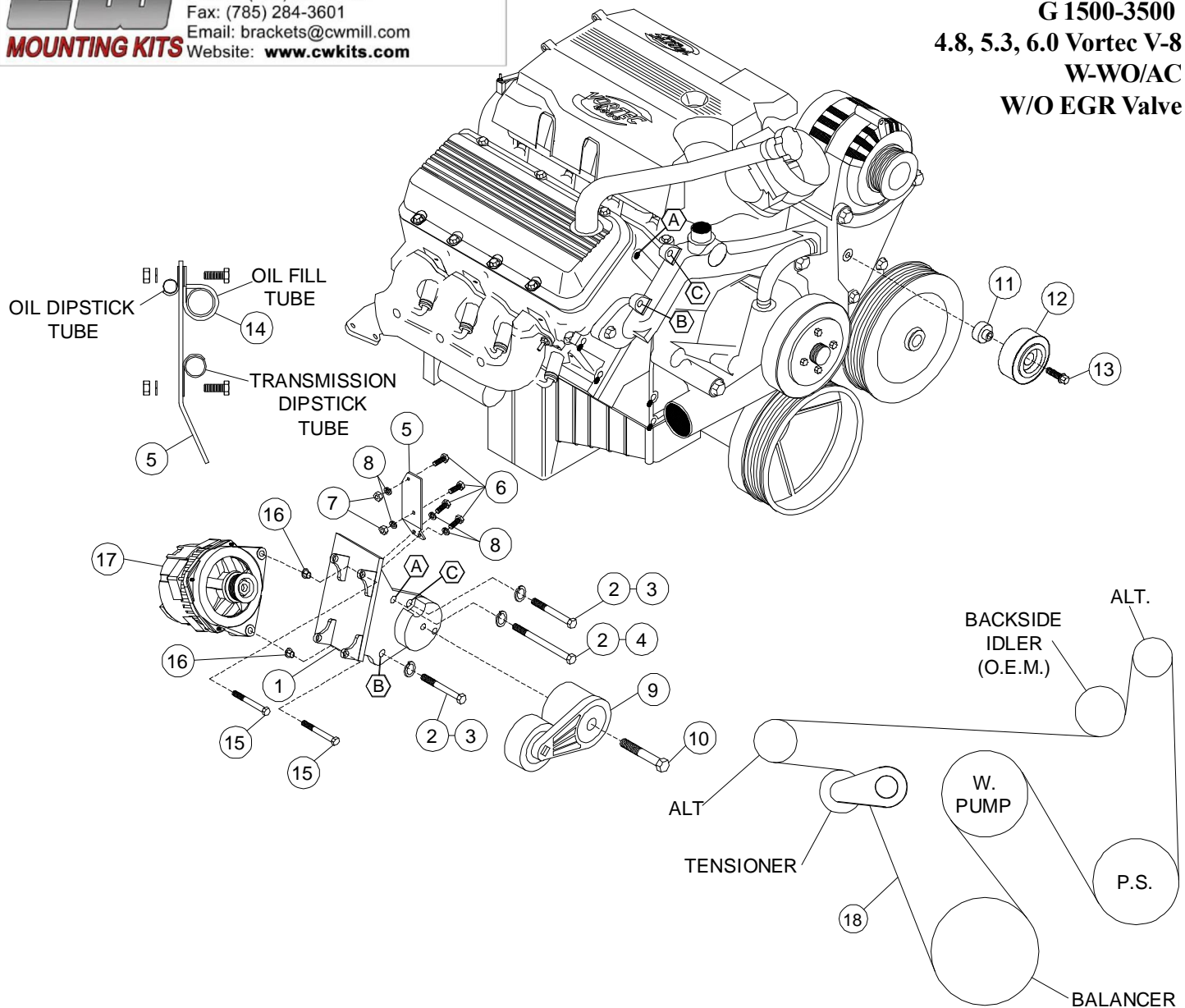

**PARTS LIST**

- 1. VCMB 38 I6 (1)
- 2. 10mm LW (3)
- 3. 10mm x 65mm (2)
- 4. 10mm x 130mm (1)
- 5. VCMB 392
- 6. 1/4 x 3/4 UNC (4)
- 7. 1/4 Nut (2)
- 8. 1/4 LW (4)
- 9. 89203 TIPCS (1)
- 10. 10mm x 60mm 1.5 (1)

- 11. CMB3867 (1)
- 12. 89006 (1)
- 13. 10mm x 40mm Flange (1)
- 14. 1" Adel Clamp (1)
- 15. 10mm x 75mm (2)
- 16. 1255-0090 Slide Bushing (2)
- 17. Alternator (Sold Separately)
- 18. Dayco 5061037 (1)