



CW MILL EQUIPMENT CO., INC.  
P.O. Box 246 • Sabetha, Kansas 66534  
(785) 284-3454 • FAX (785) 284-3601

**DMK57J180-I8**  
2007-2010 Dodge 2500-3500  
6.7 Cummins Diesel  
W-AC  
Requires 8 Groove Pulley

## INSTALLATION NOTES

---

1. Drain radiator below upper radiator hose. Remove hose. Remove driver side upper shroud support. Remove fan shroud. Remove belt. Remove return hose from power steering reservoir and let reservoir drain. Remove bolts from power steering pump through the holes in the pulley. Leaving pressure lines attached, set pump aside on passenger side of engine. Remove power steering pump brackets.
2. Install studs(2) in timing cover with nuts(4). Install 5/8 hose(16) onto return hose using hose barb(18) and hose clamps(17). Loosen front pressure hose on steering gear box and swing over frame rail. Set the aux. alternator on the driver side frame before installing the main bracket(1).
3. Install bracket(1) onto studs(2) using nuts(4). Install alternator onto bracket(1) using bolts(25,27,29), nut(26), FW(31), LW's(28,30), spacers(33,34) and slide(32). NOTE: It may be easier to install wiring before power steering pump is reinstalled. Install power steering pump onto bracket using bolts(3) and LW's(5). Install new belt(24) according to the belt diagram. Install idler(13) in lowest hole location possible while tensioner is retracted fully using bolt(15), FW(14), and bushing(12).
4. Install fan shroud. Install grommet(23) into shroud. Install hose rest(6) to head on driver side using flange head bolts (7). Secure shroud to hose rest(6) using bolt(19), flatwasher(21) and nut(20) bolting these through the grommet(23) which was installed earlier. Cut 3/4" off radiator side of top radiator hose and reinstall making sure to maintain clearance to the power steering pump. Connect new power steering return hose(16) to power steering reservoir using hose barb(18) and hose clamp (17). Fill reservoir w/ATF Plus 4 transmission fluid. Fill radiator and overflow tank. Check for proper belt tracking and clearances.

# DMK57J180-I8

2007-2010 Dodge 2500-3500

6.7 Cummins Diesel

W-AC

Requires 8 Groove Pulley

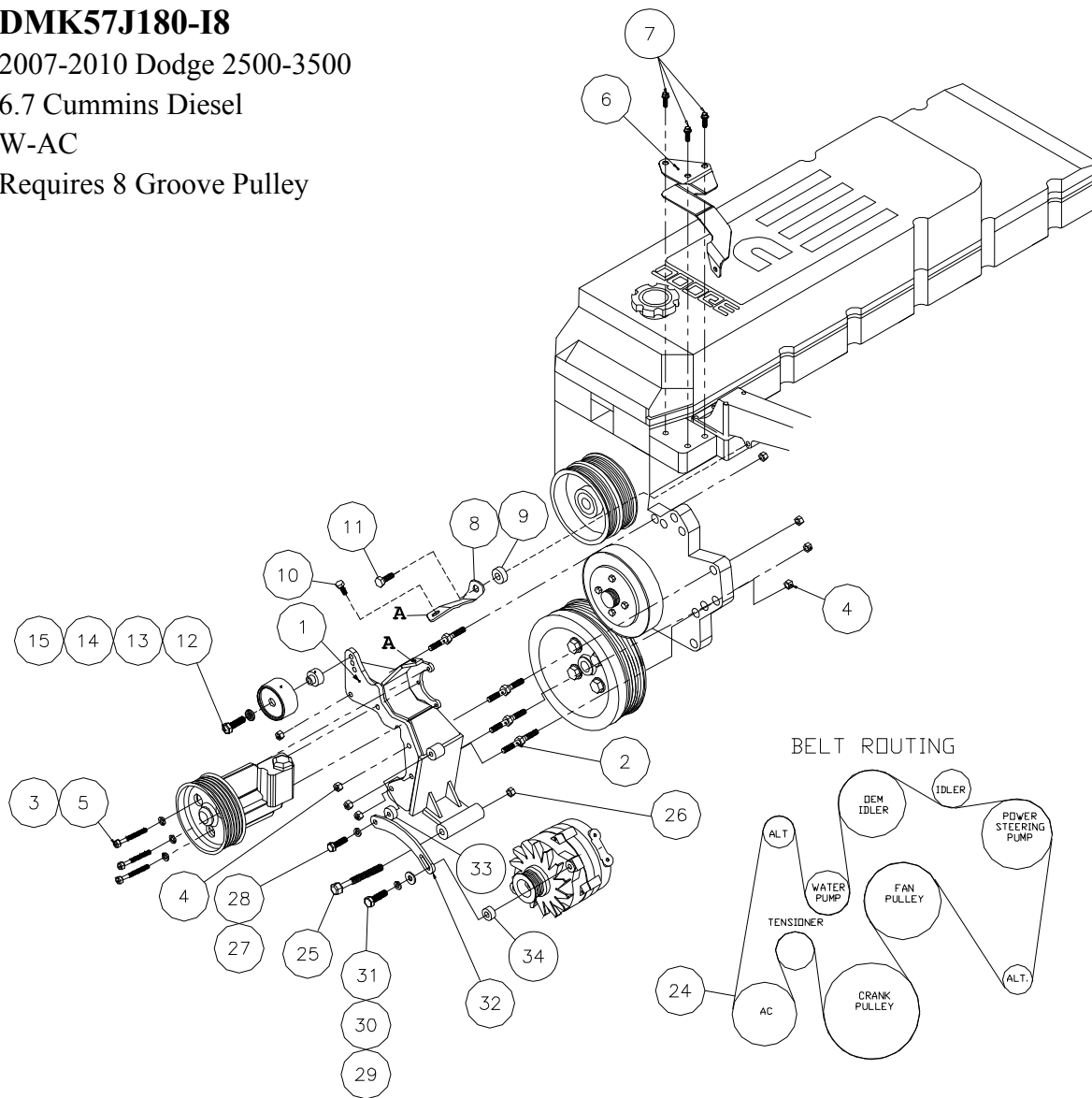

## PARTS LIST

- |                              |                                 |     |                                |
|------------------------------|---------------------------------|-----|--------------------------------|
| 1.                           | DMP57J180-I8 (1)                | 18. | 5/8 Double Ended Hose Barb (1) |
| 2.                           | 8mm Stud 08075-1.24 ST (5)      | 19. | 8mm x 45mm (1)                 |
| 3.                           | 8mm x 70mm (3)                  | 20. | 8mm Nut (1)                    |
| 4.                           | 8mm Flange Nut (8)              | 21. | 5/16 FW (1)                    |
| 5.                           | 8mm LW (3)                      | 22. | 15" Plastic Tie (1)            |
| 6.                           | DMB563 (1)                      | 23. | 1007863 Rubber Grommet (1)     |
| 7.                           | 10mm X 20mm Flanged Bolt (3)    | 24. | 5081300 Dayco (1)              |
| 8.                           | DMB574 Power Steering Brace (1) | 25. | 1/2 x 6 Bolt (1)               |
| 9.                           | SP64-.375 (1)                   | 26. | 1/2 Nut (1)                    |
| 10.                          | 8mm x 12mm Flange (1)           | 27. | 3/8 x 1-1/4 (1)                |
| 11.                          | 8mm x 30mm Flange (1)           | 28. | 3/8 LW (1)                     |
| 12.                          | DMB 562 (1)                     | 29. | 1/2 x 1-1/2 (1)                |
| 13.                          | 89016 Dayco (1)                 | 30. | 1/2 LW (1)                     |
| 14.                          | 3/8 FW (1)                      | 31. | 1/2 FW (1)                     |
| 15.                          | 10mm X 45mm Bolt (1)            | 32. | J180B3 (1)                     |
| <b>ITEMS 16-23 NOT SHOWN</b> |                                 | 33. | DMB57J180-1                    |
| 16.                          | 14"-5/8 Oil Hose (1)            | 34. | DMB57J180-2                    |
| 17.                          | #10 Hose Clamp (2)              |     |                                |