



NMK53L3S-6

Model Year: 2017-2021 Nissan NV 1500-3500 Van

Build Date: August 15, 2017 or later

5.6L V8 Gas w/-w/o A/C

Requires 6-Groove Pulley
For use with L3S Alternator

INSTALLATION NOTES

1. The buyer is responsible for providing trained and experienced installation decision making with technical know-how to apply professional judgment that specifically applies to each individual installation.
2. Be sure to read and understand all available information including but not limited to instructions, warnings, sales terms, and warranties for the vehicle and all system components prior to attempting installation.
3. Remove bottom portion of fan shroud. Remove belt. Disconnect fan wire and remove fan.
4. Remove power steering reservoir and bracket. Cut bracket as shown below and discard the lower section. Remove the zip tie from the "Y" in the wiring harness that is attached to the timing cover. It retains the wiring that goes to the power steering line.
5. Install main bracket (4) onto engine using bolts (5-6). Do not tighten completely. Use caution not to damage wiring harness located between the main bracket and timing cover. The wire to the power steering pressure sensor must be routed behind the bracket and emerge in front of bolt (6).
6. Remove top bolt from OEM alternator. Install the main bracket brace (7) to main bracket (4) using bolt (8) and to the top of the OEM alternator bracket using bolt (9).
7. Remove the crank pulley bolt. Install drive pulley (1) using bolts (2-3). First, torque bolt (2) to 138-150 lb-ft. After that then tighten bolts (3).
8. Reinstall fan, fan wire, OEM belt, and lower shroud.
9. Install tensioner assembly (24) with bolt (25). Install grooved idler (20) with hardware (21-23). Install smooth idler (16) with hardware (17-19). Attach hose brace standoff (11) with bolt (12) Install modified OEM power steering reservoir bracket with bolts (10).
10. Install auxiliary alternator slide (26) using hardware (28-29). Attach alternator to main bracket with bolt (27). Attach auxiliary alternator to slide (26) using hardware (28-30).
11. Drain enough coolant so the level is below the upper radiator hose. Remove radiator end of upper radiator hose. Cut approximately 3/4" from end of hose and reinstall. Use clamp (13) to secure upper radiator hose to hose brace standoff (11) using hardware (14-15).
12. Install belt (31) as shown.

NOTE: Before starting the engine, check to make certain no wires, hoses, etc. that may have been disturbed during installation do not come in contact with any hot or moving parts. Run the engine and check for proper belt tracking, adjust if necessary.

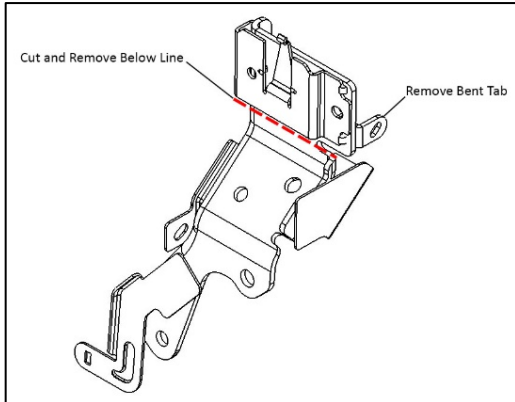

Modified Power Steering Bracket

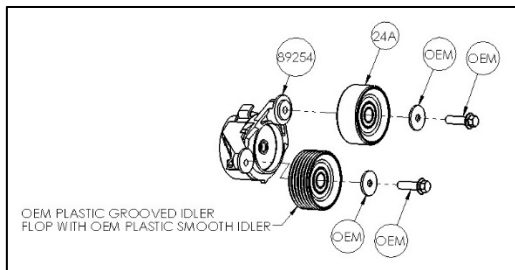

Custom Tensioner (24)

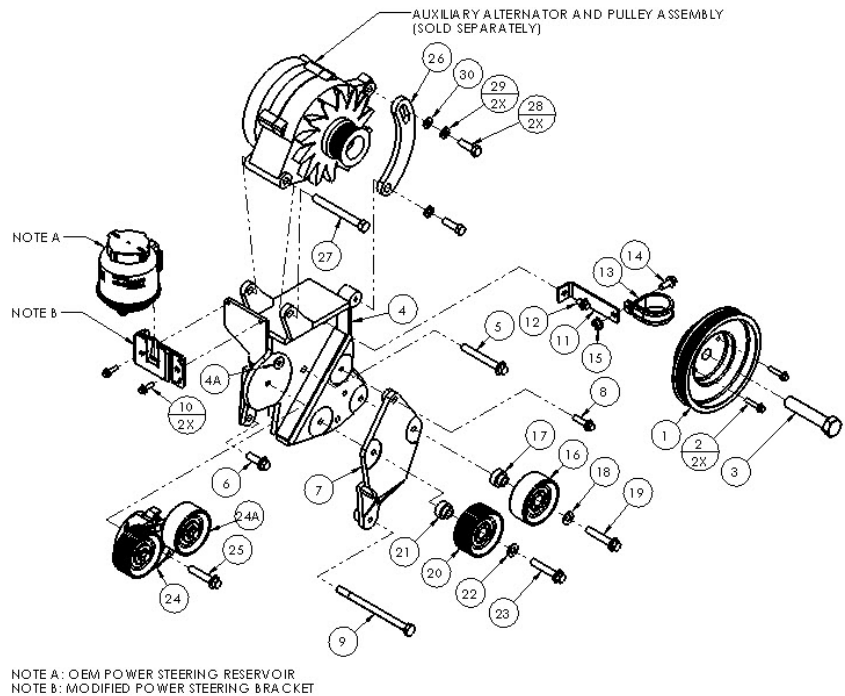

NOTE A: OEM POWER STEERING RESERVOIR
 NOTE B: MODIFIED POWER STEERING BRACKET

PARTS LIST							
Item	Part Number	Description	Qty.	Item	Part Number	Description	Qty.
Add-on Drive Pulley				Smooth Idler Pulley Assembly			
1	NPC536	Add-on Drive Pulley	1	16	89007	Dayco Smooth Idler Pulley	1
Add-on Drive Pulley Mounting Hardware				Grooved Idler Pulley Assembly			
2	1018265	M18-1.5 x 90mm Bolt	1	17	CMB3867	Machined Idler Bushing	1
3	1016342	M6-1.0 x 30mm Flange Bolt	2	18	1007644	3/8" Flat Washer	1
Main Bracket				Tensioner Assembly			
4	NMB53L3S	Main Bracket	1	20	89051	Dayco Grooved Idler Pulley	1
4a	1016338	3/8"-16 x 3/4" NC FHSCS (Included)	1	21	CMB3867	Machined Idler Bushing	1
Main Bracket Mounting Hardware				Auxiliary Alternator Mounting Hardware			
5	1006928	M10-1.5 x 80mm Flange Bolt	1	22	1007644	3/8" Flat Washer	1
6	1006927	M10-1.5 x 30mm Flange Bolt	1	23	1018225	M10-1.5 x 55mm Flange Bolt	1
Main Bracket Brace				Belt			
7	NMB53-1	Main Bracket Brace	1	24	89254-007	Custom Tensioner	1
Main Bracket Brace Mounting Hardware				Hose Brace Assembly			
8	1013349	M8-1.25 x 30mm Flange Bolt	1	24a	89007	Dayco Smooth Idler Pulley (Included)	1
9	1018264M	Modified M10-1.25 x 150mm Bolt	1	25	1006934	M10-1.5 x 50mm Flange Bolt	1
Modified OEM Power Steering Reservoir Bracket Hardware				Auxiliary Alternator Mounting Hardware			
10	1016330	M6-1.0 x 20mm Flange Bolt	2	26	L3SB3	Alternator Slide Brace	1
Hose Brace Assembly				Modified OEM Power Steering Reservoir Bracket Hardware			
11	NMB53-2	Hose Brace Standoff	1	27	1008198	7/16"-14 x 4" NC Bolt	1
12	1011623	M8-1.25 x 12mm Flange Bolt	1	28	1009929	3/8"-16 x 1-1/4" NC Bolt	2
13	1018242	#28 Rubber-Metal Adel Clamp	1	29	1010315	3/8" Lock Washer	2
14	1013329	M8-1.25 x 20mm Flange Bolt	1	30	1011654	5/16" Flat Washer	1
15	1013333	M8-1.25 Flange Nut	1				

CW **CW Mill Equipment Co., Inc.**
14 Commerce Drive Sabetha, KS 66534
Phone: (785) 284-3454
Fax: (785) 284-3601
Email: brackets@cwmill.com
Website: www.cwkits.com

MOUNTING KITS

NMK53L3S-6

Model Year: 2017-2021 Nissan NV 1500-3500 Van
Build Date: August 15, 2017 or later
5.6L V8 Gas w/-w/o A/C

Requires 6-Groove Pulley
For use with L3S Alternator

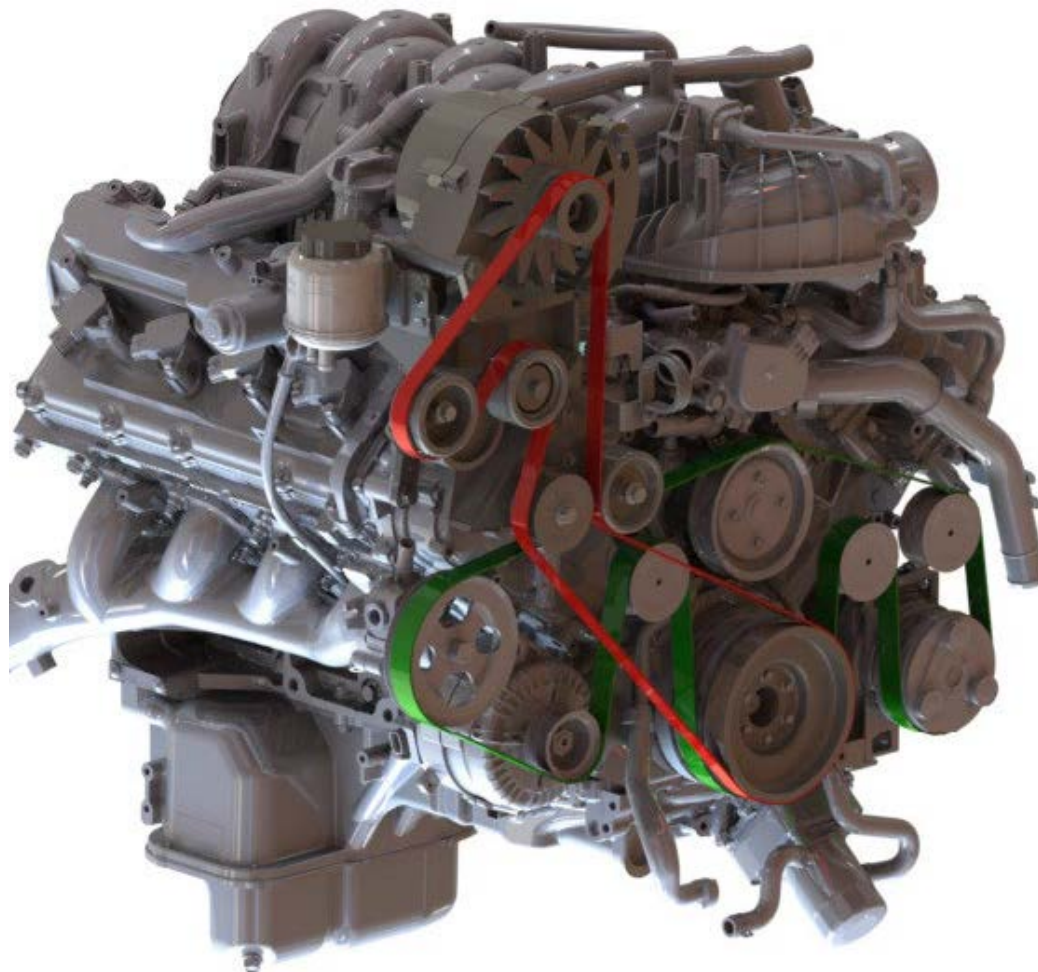

Disclaimer: (1.) Due to the custom nature and variation of all add-on systems of this type, no complete system kits are offered by the manufacturer, and any group of parts marketed as a kit is limited to only the individually defined parts in that specific kit. The system designer's rotating accessory components are not included, offered, or fully known by the manufacturer. In addition to the absence of the rotating accessory system, other potential components such as additional clamps, brackets, wear liners, hardware, or other items that may be required by the system designer must be identified and supplied by the actual system designer. (2.) Due to vehicle manufacturer's assembly tolerances, production changes, and installation variances, it is the buyer's responsibility to insure adequate clearance for all components including space for and safe location of the fan, radiator, all lines, and wires. Check for possible movement, vibration, friction points, heat exposure and/or shifting of any and all components such as hoses, wires, and all other components including those that may otherwise be considered non-moving and/or unaffected by the installation (3.) The buyer is responsible for the entire installation of a mounting kit as the mounting kit as the mounting kit is part of a custom process controlled by the buyer through their whole system design and directed installer as the installer evaluates, locates, routes, aligns, and tightens all components while determining if additional clamps, brackets, wear-liners, or other components may be required, beyond those included in the kit. Any additional items required, beyond those included in the kit, are to be provided at the expense of the buyer. (4.) the buyer is responsible for the development and communication of their whole system installation procedures, safety precautions, application, and use of the engine accessory mounting kit in their system, including efforts to maintain vehicle control and prevent pinch, wear, impact, and/or burn exposure on all hoses, wires, and other parts. (5.) The buyer is responsible for providing trained and experienced installation decision making with technical know-how to apply professional judgment that specifically applies to each individual installation. The buyers chosen installers must be qualified and experienced technicians that are familiar with the vehicle and accessory being mounted as well as the buyer's whole system design and installation procedures associated with the kit. (6.) The buyer is responsible for determining and achieving compliance to all regulatory issues that apply to the use of all products. (7.) The manufacturer reserves the right to make changes and/or improvements to any product at any time with or without notice.