

INSTALLATION NOTES

1. Disconnect the battery and drain engine coolant. Remove the fan and upper radiator hose, fan has right hand threads. (It is not necessary to remove the fan from the fan shroud, but care must be taken not to damage the radiator). Remove the damper bolt and clean any silicone or dirt from the damper pilot. Install the pump drive pulley (1) using bolt (2). Torque the bolt to 150-160 ft. lbs. Install set screws (3) into the pulley using a mild grade of loc-tite and turn them in until they just make contact with the damper. Cross tighten them 1/8 turn at a time until you reach 35-40 **Inch lbs.** NOTE: (ALLEN BOLTS MUST BE TIGHTENED EVENLY).
2. Remove the water pump. Install new water pump(33) reusing O.E.M. bolts. Remove the clip holding the hose onto the radiator reservoir and remove the hose. Remove the power steering reservoir from the fan shroud and drain the fluid. Relocate the ABS module rearward with included hardware (21-24). Remove the top two bolts from the driver's side timing cover and install the studs(5). Remove the bolt from the idler on the driver's side, but leave the idler installed. Install the alternator using bolts(13), (18) washers (14), (19), (20) and nut (17) onto the bracket(4). Install the bracket assembly onto the engine with the bottom bushing going over the existing idler location on the timing cover using bolt(7) and nuts(6). Tighten securely. Install the idlers (8) using bushings (9) and bolts(10). Install tensioner (11) using bolt (12). Install the belt (15) as shown in diagram.
3. Replace the upper radiator hose to its original location. Using hose hardware included (26-29) reroute the radiator reservoir hose. Approximately 1" can be cut from the nipple on the reservoir to let the 90 degree elbow go on further and gain more clearance to the pump. Install the power steering reservoir hose extension replace and refill the reservoir. Use hose clamp provided to secure the power steering hose to the bracket just below the alternator pulley. Install the fan spacer(16) and fan.
4. Make certain all wires and hoses will not come on contact with any hot or moving parts. Run the engine and check for proper belt tracking.

FMK48L3S-8WP

2011-2016 Ford F-250-F-350 Super Duty

6.2L V8 Gas

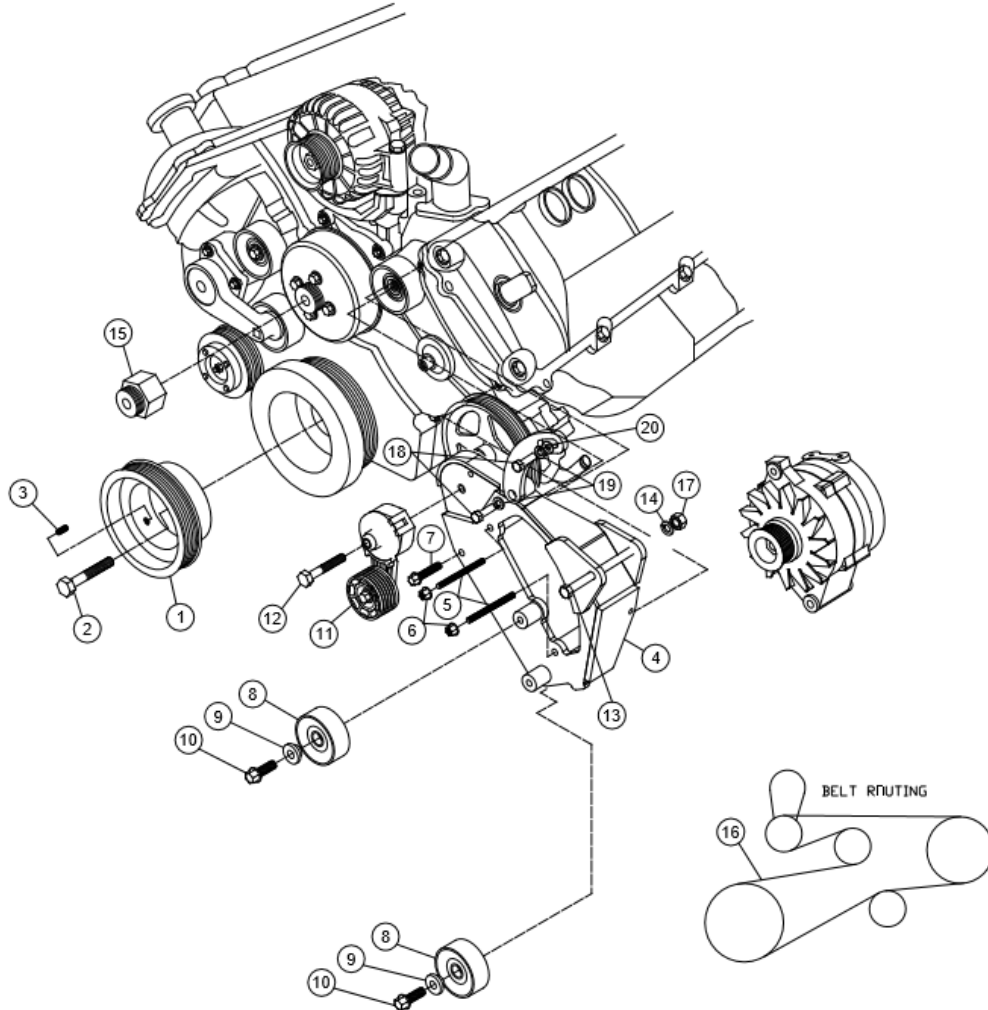

PARTS LIST

1. FPC488 (1)
2. 14mm x 120mm (1)
3. 8mm x 16mm Set Screw (3)
4. FMP 48L3S-8 (1)
5. 8mm x 130mm Stud (2)
6. 8mm Flange Nut (2)
7. 8mm x 50mm Flange Bolt (1)
8. 89016 Dayco (2)
9. FMB 480 Alignment Bushing (2)
10. 10mm x 30mm Flange Bolt (2)
11. 89213-8 Tensioner (1)
12. 12mm x 65mm Short Head (1)
13. 7/16x5.5 Bolt (1)
14. 7/16 Lock Washer
15. 5080745 Dayco (1)
16. FSK 6.8B (1)
17. 7/16 Nut (1)
18. 3/8x1.25 Bolt (2)
19. 3/8 Lock Washer
20. 7/16 Flat Washer

ITEMS 21-24 (ABS BRAKE MODULE KIT) NOT SHOWN

21. FMB 481 (Module Bracket) (1)
22. FMB 482 (Module Bracket) (1)
23. 8mm x 20mm Flange Bolt (1)
24. 8mm Flange Nut (3)

ITEMS 25-28 (COOLANT HOSE KIT) NOT SHOWN

25. FMB 484 (Coolant Hose Extension) (1)
26. 4200-16-16 Hose Barb (1)
27. #16 Hose Clamp (3)
28. #20 Hose Clamp (2)

ITEMS 29-33 (P.S. HOSE KIT) NOT SHOWN

29. 4" of 3/4" Oil Hose (1)
30. 4200-12-12 Hose Barb (1)
31. #12 Hose Clamp (2)
32. #20 Hose Clamp (1)
33. 6.2L Heavy Duty Water Pump (1)

