



CW MILL EQUIPMENT CO., INC.
P.O. Box 246 • Sabetha, Kansas 66534
(785) 284-3454 • FAX (785) 284-3601

DMK 51 — 2 Belts
1989-91 DODGE TRUCK, D-250-350
5.9 Cummins Diesel W-WO/AC
(Serpentine)

INSTALLATION NOTES

1. Disconnect battery, loosen battery in tray. Remove fan with 1 7/16" wrench, threads are left-handed, tap wrench toward driver's side fender. Let fan lay in shroud.
2. Remove oil fill tube from front of engine, cover unscrews. Install oil seal from fill tube onto hole cover (7), install hand tight only. Replace front valve cover with cover (4) and cap (5 & 6) using shoulder bolt (22) and rubber grommet (23), re-use gasket.

NOTE: Oil must be added 1 quart at a time; use of a pressurized oil filler pump will cause oil to spew out valve cover.

3. Loosen serpentine belt from alternator pulley, insert 3/8 inch drive ratchet or breaker bar into square hole on idler assembly. Leave belt wrapped on engine pulleys.
4. Remove pulley from fan idler assembly. Replace with drive pulley (1), secure bolts (2). Tension serpentine belt, make sure belt is properly seated on all pulleys, misalignment will quickly damage belt on start-up. Replace fan and tighten by tapping wrench with hammer.
5. Install bracket (8) with bolts (10 & 12) provided, secure all bolts. Loosely bolt clutch pump to pump plate (9) with pump bolts provided. Align clutch pulley to drive pulley (1), tighten pump bolts securely. **IMPORTANT:** Make sure throttle linkage will not make contact with bracket (8), trim bracket if necessary to provide clearance.
NOTE: Corner of fan shroud may need to be notched for clutch clearance.
6. Install pump drive belts (21), adjust pump plate (9) for proper belt tension. Tighten bolts (14 & 15) on pump plate.
7. Secure battery in tray as far from clutch as possible.
IMPORTANT: Make sure clutch cannot contact battery during operation. Relocate battery closer to fender if necessary. Connect battery.

NOTE: Make sure pump drive belts have adequate clearance to fan.

DMK 51- 2 Belts
 1989-91 DODGE
 5.9 Cummins Diesel
 W-WO/AC (Serpentine)

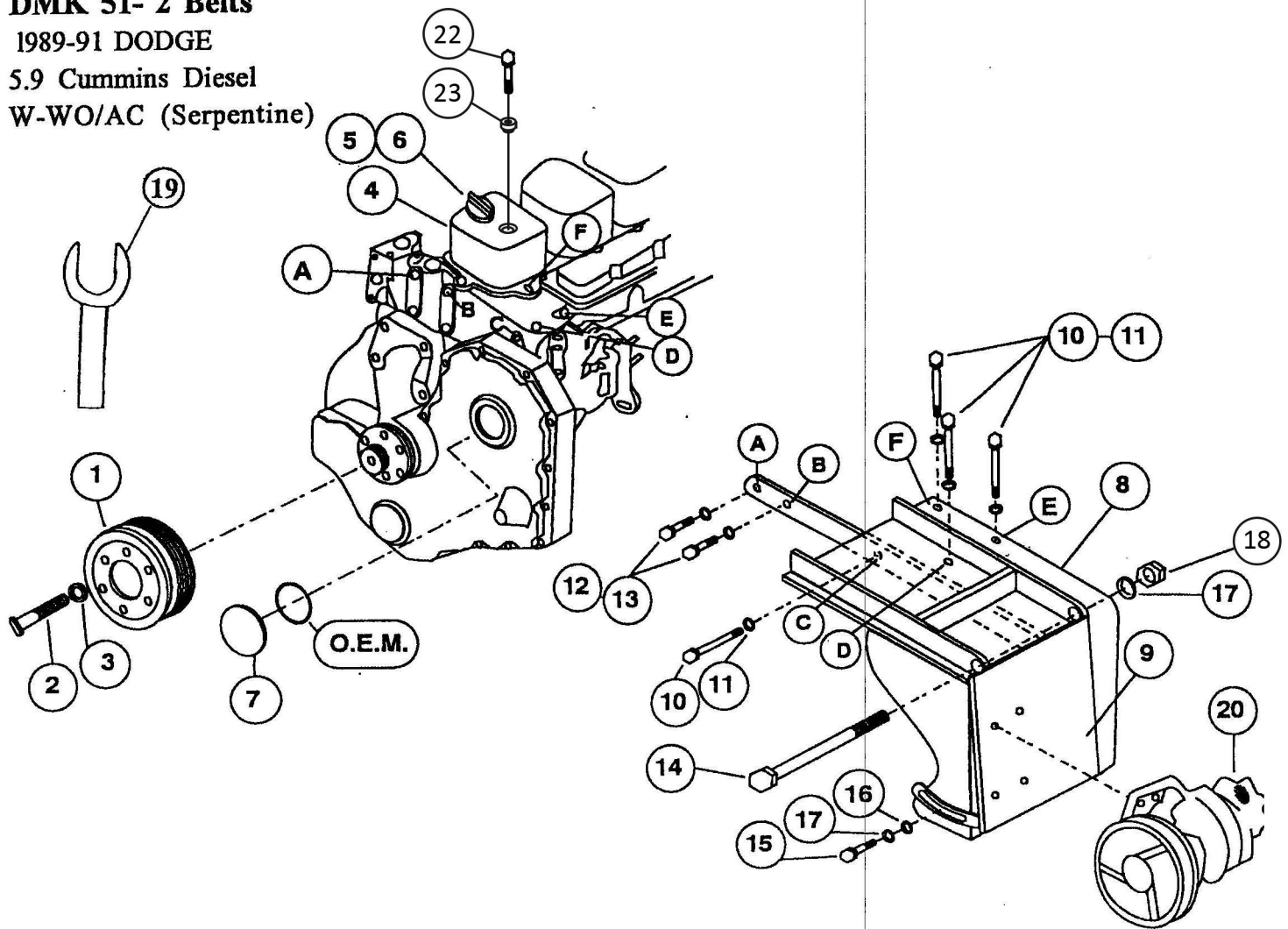

PARTS LIST

- | | |
|-------------------------|---|
| 1. DPC 512 (1) | 12. 8mm X 25mm 1.25 (2) |
| 2. 6mm X 16mm 1.0 (6) | 13. 8mm LW (2) |
| 3. 6mm LW (6) | 14. 3/8 X 4 1/2 NC (1) |
| 4. Valve Cover (1) | 15. 3/8 X 1 1/4 NC (1) |
| 5. Fill Cap (1) | 16. 3/8 FW (1) |
| 6. Cap Seal | 17. 3/8 LW (2) |
| 7. Hole Cover | 18. 3/8 NC (1) |
| 8. DMB 510 (1) | 19. 1 7/16 wrench |
| 9. DMP 51 (0-4) (1) | 20. Clutch Pump (1) |
| 10. 10mm X 30mm 1.5 (4) | (Sold Separately) |
| 11. 10mm LW (4) | 21. *AX-49 (2) (Not Shown)(#2-AX-48,#4-AX-47) |
| | 22. Shoulder Bolt (1) |
| | 23. Rubber Grommet (1) |

*NOTE: with 7" clutch : #2-AX-50 #4-AX-49.

NOTE: Move battery in tray toward fender for additional clearance to clutch pump.