

## INSTALLATION NOTES

---

1. Disconnect battery, loosen battery in tray. Remove fan with 1 1/2" wrench, threads are left-handed, tap wrench toward driver's side fender. Remove fan and shroud, shroud held in with clips.
2. Remove oil fill tube from front of engine, cover unscrews. Install oil seal from fill tube onto the hole cover (7), install hand tight only. Replace front valve cover with cover (4) and cap (5 & 6) using shoulder bolt (21) and rubber grommet (22), re-use gasket.  
**NOTE:** Oil must be added 1 quart at a time; use of a pressurized oil filler pump will cause oil to spew out valve cover.
3. Loosen serpentine belt from alternator pulley, insert 3/8 inch drive ratchet or breaker bar into square hole on idler assembly. Leave belt wrapped on engine pulleys.
4. Remove pulley from fan idler assembly. Replace with drive pulley (1), secure bolts (2). Tension serpentine belt, make sure belt is properly seated on all pulleys, misalignment will quickly damage belt on start-up.
5. Install bracket (8) with bolts (10 & 12) provided, secure all bolts. Loosely bolt clutch pump to pump plate (9) with pump bolts provided. Align clutch pulley to drive pulley (1), tighten pump bolts securely. **IMPORTANT:** Make sure throttle linkage will not make contact with bracket (8), trim bracket if necessary to provide clearance.  
**NOTE:** Corner of fan shroud may need to be notched for clutch clearance.
6. Install pump drive belts (19), adjust pump plate (11) for proper belt tension. Tighten bolts (14 & 15) on pump plate.
7. Secure battery in tray as far from clutch as possible.  
**IMPORTANT:** Make sure clutch cannot contact battery during operation. Relocate battery closer to fender if necessary. Connect battery.

**NOTE:** Make sure pump drive belts have adequate clearance to fan and fan has clearance to radiator.

**NOTE:** Make sure electric sender on fuel pump has clearance to bracket (10) and wires are protected to prevent damage.

**NOTE:** Move battery in tray toward fender for additional clearance to clutch pump.

# DMK 52 -1 Belt

1991-93 Dodge Truck 250,350

5.9 Cummins Diesel

W-WO/AC, W/Oil Intercooler

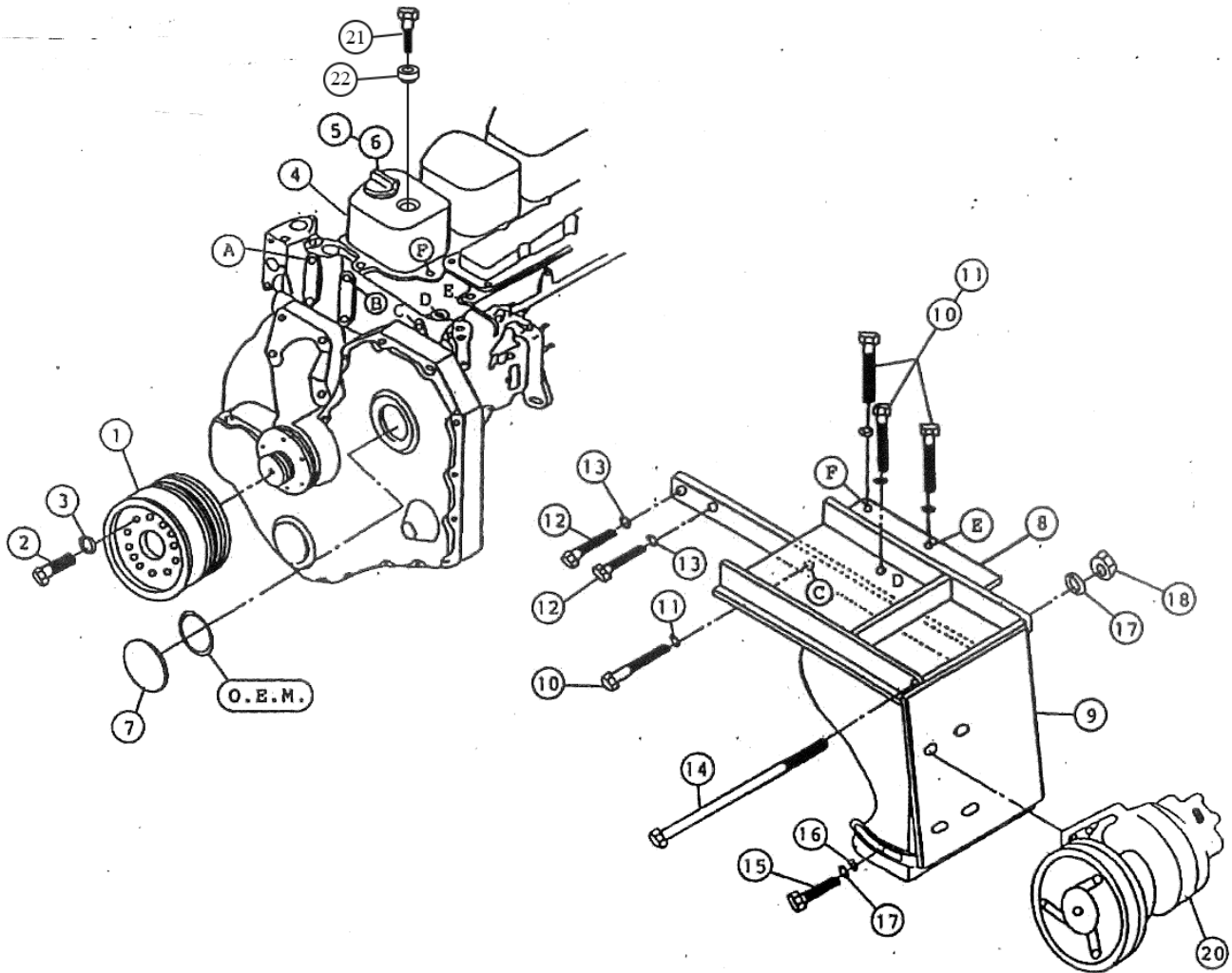

## PARTS LIST

- |                         |   |
|-------------------------|---|
| 1. DPC 521 (1)          | 11. 10mm LW (4)                                   |
| 2. 6mm x 16mm 1.0 (6)   | 12. 8mm x 25mm 1.25 (2)                           |
| 3. 6mm LW (6)           | 13. 8mm LW (2)                                    |
| 4. Valve Cover (1)      | 14. 3/8 x 4 1/2 NC (1)                            |
| 5. Fill Cap (1)         | 15. 3/8 x 1 1/4 NC (1)                            |
| 6. Cap Seal (1)         | 16. 3/8 FW (1)                                    |
| 7. Hole Cover (1)       | 17. 3/8 LW (2)                                    |
| 8. DMB 520 (1)          | 18. 3/8 NC (1)                                    |
| 9. DMP 52(0-4) (1)      | 19. A50F (1) (Not Shown) (#2 A49F, #4A48F)        |
| 10. 10mm x 30mm 1.5 (4) | 20. Clutch Pump Assembly (1)<br>(Sold Separately) |
|                         | 21. Shoulder Bolt (1)                             |
|                         | 22. Rubber Grommet (1)                            |

**NOTE:** With 7" clutch: #2 A51F, #4 A50F.