



**CW Mill Equipment Co., Inc.**

14 Commerce Drive Sabetha, KS 66534

Phone: (785) 284-3454

Fax: (785) 284-3601

Email: [brackets@cwmill.com](mailto:brackets@cwmill.com)

Website: [www.cwkits.com](http://www.cwkits.com)

## VFLMK25J180-6

2019-2022 Freightliner/Mercedes 2500-4500 Sprinter  
3.0L V6 Diesel w/-w/o AC, Requires 6 Groove Pulley

Wrenches are Available and Suggested for Removal and Retorquing  
Harmonic Balancer Bolt, Part# VFL23WR-1 & VFL23WR-2.  
These Are Sold Separately.

### INSTALLATION NOTES

---

1. The buyer is responsible for providing trained and experienced installation decision making with technical know-how to apply professional judgment that specifically applies to each individual installation.
2. Be sure to read and understand all available information including but not limited to instructions, warnings, sale terms, and warranties for the vehicle and all system components prior to attempting installation.
3. Remove air cleaner assembly. Remove the fan and fan shroud. Fan nut has left-hand threads. Remove harmonic balancer bolt using wrench (Part# *VFL23WR-1* sold separately) (Bolt has right hand threads).
4. Install pulley adapter (1) using bolt (3), OEM spacer, and set screws (4). Torque harmonic balancer bolt to 280 ft/lbs. using wrench (Part# *VFL23WR-2* sold separately). Cross-torque set screws at 10 in/lbs., 30 in/lbs., 60 in/lbs., 90 in/lbs., 120 in/lbs. Mild-grade of Loctite is advisable to use. Install drive pulley (2) with bolts (5) to pulley adapter (1). Install studs (9) at location (A, B), studs (10) at location (C, D) and torque to 5 ft/lbs. Install main bracket (6) with nuts (17) at locations "A" and "B". Check for gap at locations "C" and "D" with feelers gauge. Remove bracket (6) and install appropriate shims (27, 28, 29) on studs at locations "C" and "D". Remove the two lower bolts from the OEM alternator. Reinstall main bracket (6) and then brace (16) using nuts (17). Do not tighten. Install the two lower alternator bolts back into alternator through the brace (16) Torque bolts to 20 ft/lbs. and nuts (17) to 20 ft/lbs. Install front brace (7) using bolts (12, 13), lock washer (11), and spacer (8). Install belt tensioner (14) using bolt (15) and flat washer (24).
5. Install alternator using bolts (18, 20, 22), nut (19), and washers (21). Install new drive belt (26). Install fan spacer (25), fan, and fan shroud. Fan shroud will need to be trimmed for clearance with the drive belt tensioner. Run the engine and check for proper belt tracking and clearances.



**CW Mill Equipment Co., Inc.**  
 14 Commerce Drive Sabetha, KS 66534  
 Phone: (785) 284-3454  
 Fax: (785) 284-3601  
 Email: brackets@cwmill.com  
 Website: [www.cwkits.com](http://www.cwkits.com)

# VFLMK25J180-6

2019-2022 Freightliner/Mercedes 2500-4500 Sprinter  
 3.0L V6 Diesel w/-w/o AC, Requires 6 Groove Pulley

Wrenches are Available and Suggested for Removal and Retorquing  
 Harmonic Balancer Bolt, Part# VFL23WR-1 & VFL23WR-2.  
 These Are Sold Separately.

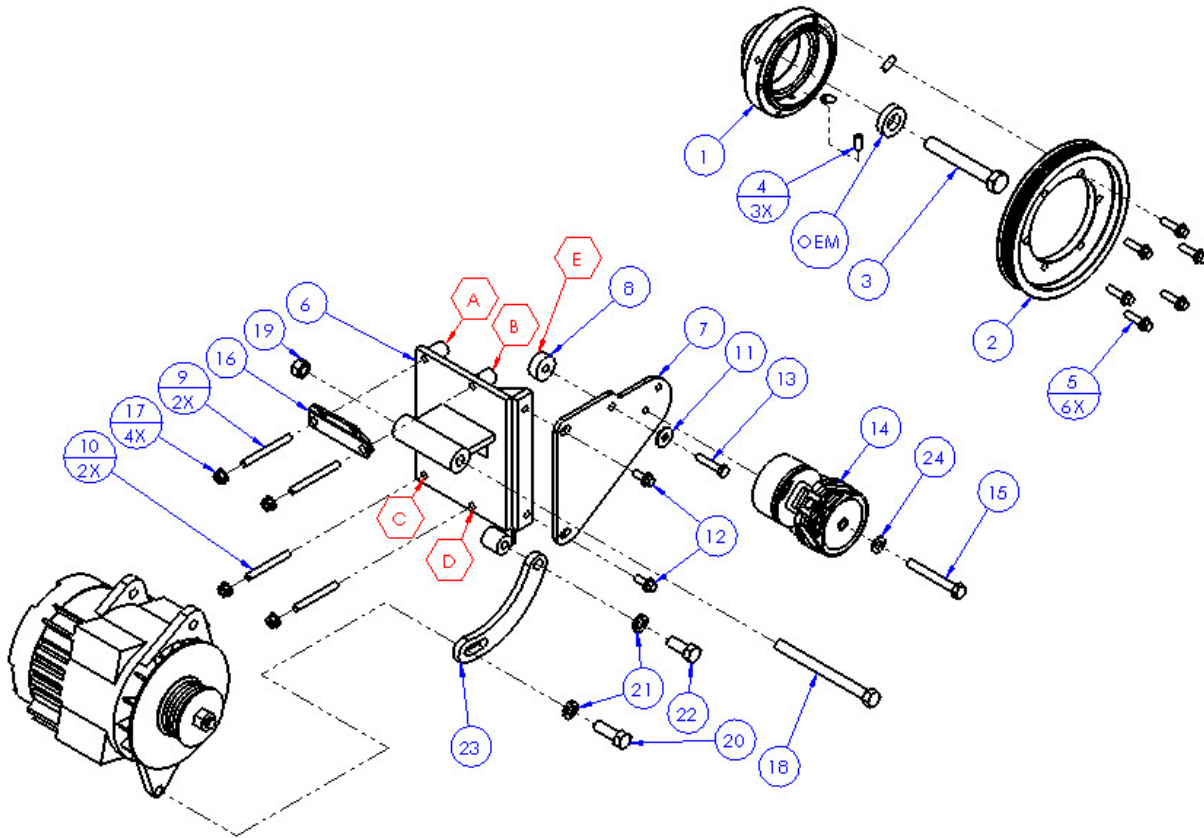

PARTS LIST					
Item	Description	Qty.	Item	Description	Qty.
<b>Pulley Assembly</b>			16	VFLMB232	1
1	VFLPA23	1	17	8mm Flange Nut	4
2	VFLPC236-7.5	1	18	1/2" x 6" Bolt	1
3	18mm x 110mm x 1.5 Bolt	1	19	1/2" Nut	1
4	8mm x 20mm Set Screw	3	20	1/2" x 1-1/2" Bolt	1
5	8mm x 30mm Flange Bolt	6	21	1/2" Lock Washer	2
<b>Bracket Assembly</b>			22	1/2" x 1-1/4" Bolt	1
6	VFLMP25J180	1	23	J180B3	1
7	VFLMB231	1	24	3/8" Flat Washer	1
8	SP125-.500	1	25	FSK38 (Not Shown)	1
9	8mm x 80mm Stud	2	<b>Belt</b>		
10	8mm x 70mm Stud	2	26	K060478 Gates	1
11	8mm Lock Washer	1	<b>Shims (Not Shown)</b>		
12	10mm x 20mm Flanged Bolt	2	27	.005" Shims	2
13	8mm x 35mm Bolt	1	28	.010" Shims	2
14	89200C Tensioner	1	29	.020" Shims	2
15	10mm x 75mm Bolt	1			



## CW Mill Equipment Co., Inc.

14 Commerce Drive Sabetha, KS 66534

Phone: (785) 284-3454

Fax: (785) 284-3601

Email: brackets@cwmill.com

Website: [www.cwkits.com](http://www.cwkits.com)

## VFLMK25J180-6

2019-2022 Freightliner/Mercedes 2500-4500 Sprinter

3.0L V6 Diesel w/-w/o AC, Requires 6 Groove Pulley

Wrenches are Available and Suggested for Removal and Retorquing Harmonic Balancer Bolt, Part# VFL23WR-1 & VFL23WR-2. These Are Sold Separately.

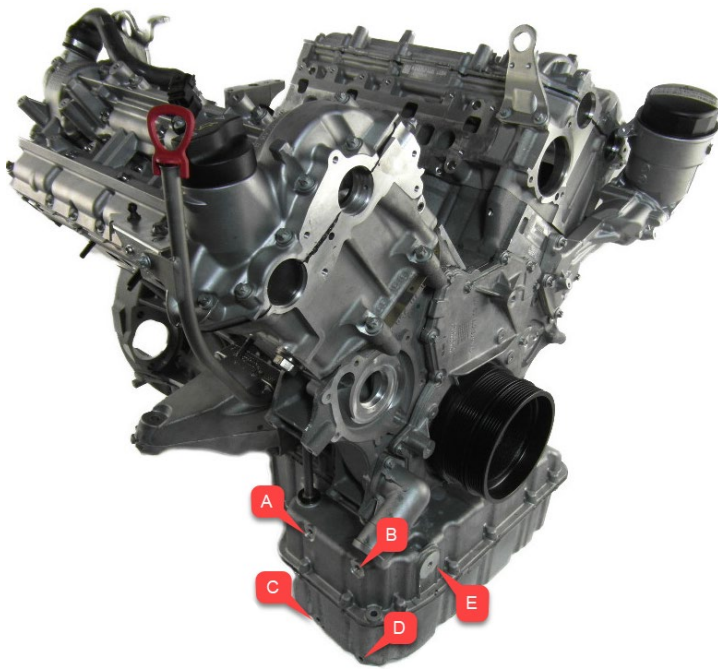

Mounting Location

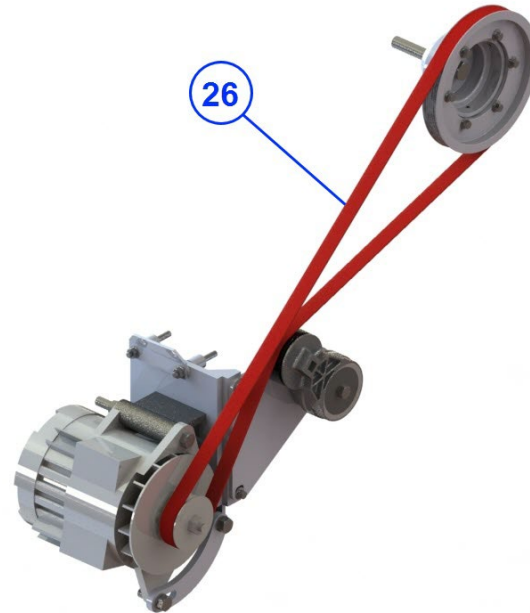

Belt Routing

Disclaimer: (1.) Due to the custom nature and variation of all add-on systems of this type, no complete system kits are offered by the manufacturer, and any group of parts marketed as a kit is limited to only the individually defined parts in that specific kit. The system designer's rotating accessory components are not included, offered, or fully known by the manufacturer. In addition to the absence of the rotating accessory system, other potential components such as additional clamps, brackets, wear liners, hardware, or other items that may be required by the system designer must be identified and supplied by the actual system designer. (2.) Due to vehicle manufacturer's assembly tolerances, production changes, and installation variances, it is the buyer's responsibility to ensure adequate clearance for all components including space for and safe location of the fan, radiator, all lines, and wires. Check for possible movement, vibration, friction points, heat exposure and/or shifting of any and all components such as hoses, wires, and all other components including those that may otherwise be considered non-moving and/or unaffected by the installation (3.) The buyer is responsible for the entire installation of a mounting kit as the mounting kit is part of a custom process controlled by the buyer through their whole system design and directed installer as the installer evaluates, locates, routes, aligns, and tightens all components while determining if additional clamps, brackets, wear-liners, or other components may be required, beyond those included in the kit. Any additional items required, beyond those included in the kit, are to be provided at the expense of the buyer. (4.) The buyer is responsible for the development and communication of their whole system installation procedures, safety precautions, application, and use of the engine accessory mounting kit in their system, including efforts to maintain vehicle control and prevent pinch, wear, impact, and/or burn exposure on all hoses, wires, and other parts. (5.) The buyer is responsible for providing trained and experienced installation decision making with technical know-how to apply professional judgment that specifically applies to each individual installation. The buyers chosen installers must be qualified and experienced technicians that are familiar with the vehicle and accessory being mounted as well as the buyer's whole system design and installation procedures associated with the kit. (6.) The buyer is responsible for determining and achieving compliance to all regulatory issues that apply to the use of all products. (7.) The manufacturer reserves the right to make changes and/or improvements to any product at any time with or without notice.