



FMK266A-8

**2023 *Dwknf"Fcvq"2302304245"qt"Ncvgt+"Ford F-250-F-550 Super"Duty
809N"X:"RQ YGTUVTQMG"FKGUGN**

For use W-WO AC, W/O OEM Dual Alternators."Y/YQ"Ckt"Dtcngu
W/O Ford ProPower Option

Requires SAE Two-Bolt A-Flange Pump Mount Only,
Requires 6-Groove Clutch, Must Use Side Ported Pump with 45° Fittings,
Pump Restricted To 2.2 Cu. In. Due To Clearance Issues

INSTALLATION NOTES

1. Disconnect batteries. Remove the air cleaner from the passenger side and the charge air tube from the driver's side. Remove the P/S reservoir from the fan shroud and lay aside. It is not necessary to drain any P/S fluid. Remove the top half of the fan shroud. Unplug the fan wire and remove the fan. Fan nut has right hand threads. Remove the top two fan diffuser nuts. Remove the belt and tensioner. Remove the 5 bolts holding the fan hub to the engine and remove it from the engine compartment. Retain the bolts for use in installation.
2. Remove the four bolts from the crank pulley and install the new drive pulley(1) using bolts (2) **On 2016 models trucks make certain the machined cavity in the pulley is aligned with the counter weight on the inside of the damper** A mild grade of lock-tite is recommended. Install pump onto bracket(3) using bolts(19), flatwashers(20), lockwashers(21) and nuts(22). It might be necessary to have the fittings installed before sliding the bracket against the engine. Remove the split bushings from the OEM bracket and install them into the new bracket. Install the main bracket(3) in place of the fan hub reusing the OEM bolts. Install clutch and coil per manufacturers instructions. Always check pump alignment with drive pulley.
3. Install the OEM tensioner and the OEM belt back onto the engine as shown in illustration on back. Remove the idler from the OEM fan hub and remove the bolt from the idler. Install the O.E.M. idler using bolt(13), lockwasher(8), flatwasher(7) and bushing(10). Install the pump tensioner bracket(4) onto the bracket and engine using bolts(5,6). Install idler(15) with the short bushing(11) to tensioner bracket(4) using bolt(14), lockwasher(8), and flatwasher(7). Install idler(15) with the long bushing(9) onto bracket(3) using bolt(12), lockwasher(8) and flatwasher(7). Install tensioner(16) using bolt(17). Install pump drive belt as shown in illustration on back. Achieving proper belt alignment is the installer's responsibility.
4. Replace the nuts onto the fan diffuser. It may be necessary to trim the diffuser if it hits the clutch. Replace the fan. Tighten the fan nut, then rotate the wire holder up and bolt it to bracket(4) using bolt(18). Replace the fan shroud. Connect the pump hoses. Replace the air cleaner and charge air tube.
5. Make certain no wires come in contact with any moving or hot parts.

CW Mill Equipment Co., Inc. Mounting Kit and Mounting Kit Component Disclaimer: (1.) Due to the custom nature and variation of all add-on systems of this type, no complete system kits are offered by the manufacturer, and any group of parts marketed as a kit is limited to only the individually defined parts in that specific kit. The system designer's rotating accessory components are not included, offered, or fully known by the manufacturer. In addition to the absence of the rotating accessory system, other potential components such as additional clamps, brackets, wear liners, hardware, or other items that may be required by the system designer must be identified and supplied by the actual system designer. (2.) Due to vehicle manufacturer's assembly tolerances, production changes, and installation variances, it is the buyer's responsibility to ensure adequate clearance for all components including space for and safe location of the fan, radiator, all lines, and wires. Check for possible movement, vibration, friction points, heat exposure and/or shifting of any and all components such as hoses, wires, and all other components including those that may otherwise be considered non-moving and/or unaffected by the installation (3.) The buyer is responsible for the entire installation of a mounting kit as the mounting kit is part of a custom process controlled by the buyer through their whole system design and directed installer as the installer evaluates, locates, routes, aligns, and tightens all components while determining if additional clamps, brackets, wear-liners, or other components may be required, beyond those included in the kit. Any additional items required, beyond those included in the kit, are to be provided at the expense of the buyer. (4.) The buyer is responsible for the development and communication of their whole system installation procedures, safety precautions, application, and use of the engine accessory mounting kit in their system, including efforts to maintain vehicle control and prevent pinch, wear, impact, and/or burn exposure on all hoses, wires, and other parts. (5.) The buyer is responsible for providing trained and experienced installation decision making with technical know-how to apply professional judgment that specifically applies to each individual installation. The buyers chosen installers must be qualified and experienced technicians that are familiar with the vehicle and accessory being mounted as well as the buyer's whole system design and installation procedures associated with the kit. (6.) The buyer is responsible for determining and achieving compliance to all regulatory issues that apply to the use of all products. (7.) The manufacturer reserves the right to make changes and/or improvements to any product at any time with or without notice.

06/08/2023

FMK266A-8 6

2023 (Build Date 01.01.2023 or Later) Ford F-250-F-550 Super Duty

6.7L V8 POWERSTROKE DIESEL

For use W-WO AC, W/O OEM Dual Alternators, W/-W/O Air Brakes

W/O Ford ProPower Option

Requires SAE Two-Bolt A-Flange Pump Mount Only, Requires 8 Groove Clutch, Must Use Side Ported Pump with 45° Fittings, Pump Restricted To 2.2 Cu. In. Due To Clearance Issues

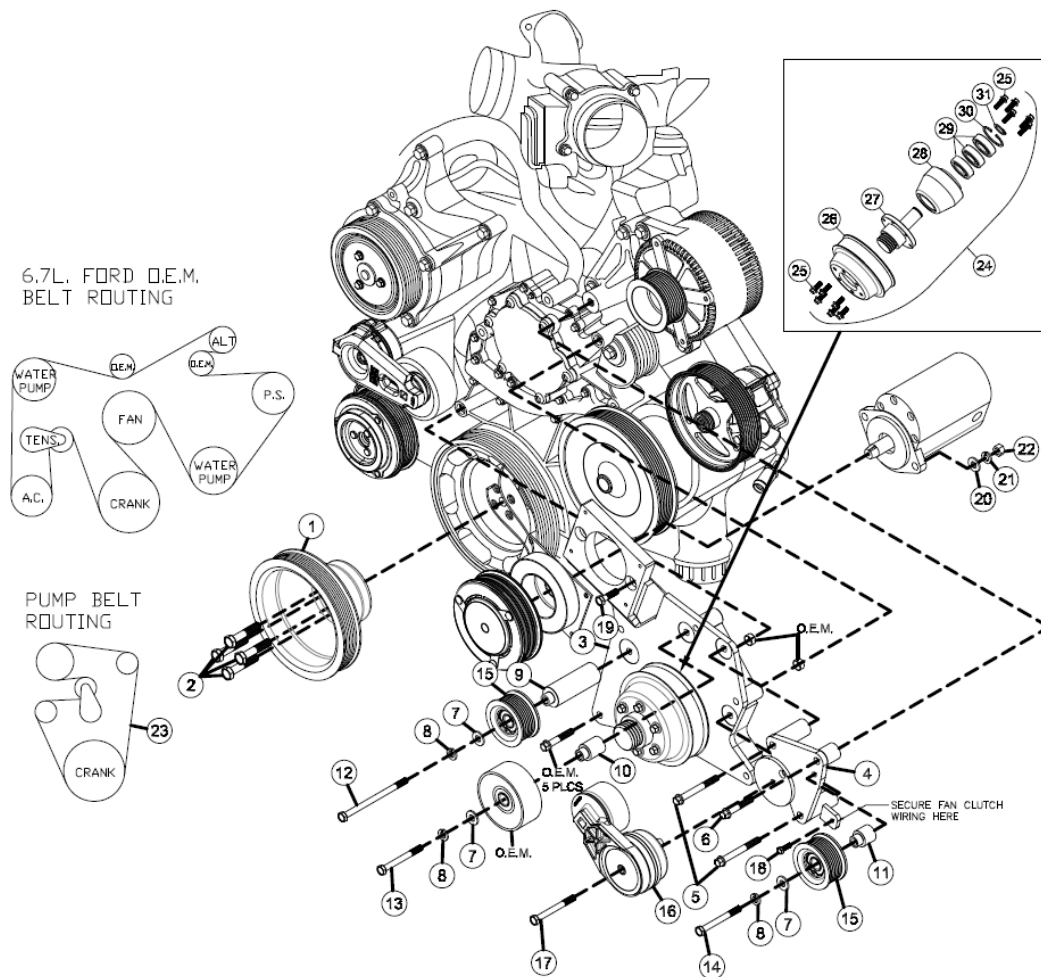

PARTS LIST

- | | |
|--|--|
| 1. FPC2638AL (1) | 18. 8mm x 12mm Flange (1) |
| 2. 12mm x 75mm 1.5 (4) | 19. 3/8 x 1-1/2 (2) |
| 3. FMP264A-8 (1) (<u>Does not include assembly 24</u>) | 20. 3/8 Flatwasher (2) |
| 4. FMB2610 (1) | 21. 3/8 Lockwasher (2) |
| 5. 10mm x 80mm Flange (2) | 22. 3/8 Nut (2) |
| 6. 10mm x 50mm Flange (1) | 23. Dayco 5080705 (1) |
| 7. 3/8 Flatwasher (3) | 24. FSK262 (1) |
| 8. 10mm Lockwasher (3) | <u>ITEM 24 INCLUDES ITEMS 25-31</u> |
| 9. FMB2617 (1) | 25. 8mm x 20mm Flange (11) |
| 10. FMB2616 (1) | 26. FPC2620 (1) |
| 11. FMB2615 (1) | 27. FSO261 (1) |
| 12. 10mm x 120mm (1) | 28. FMB2611 (1) |
| 13. 10mm x 60mm (1) | 29. MRC205SZZ Bearing (3) |
| 14. 10mm x 50mm (1) | 30. HO206ST-PA Snap Ring (1) |
| 15. 89053 (2) | 31. SH98 Snap Ring (1) |
| 16. 89470 Dayco (1) | |
| 17. 10mm x 65mm (1) | |

06/08/2023