



FMK49A-8WP

2017-2022 Ford F-250-F-350 Super Duty
6.2L V8 Gas w/ A/C

Requires SAE Two-Bolt 'A' Flange Pump, 8-Groove Clutch
Recommended 1.75 in³ or 8 gal. Pump w/ 12hp Restriction

NOTE: Must Use Rear Ported Pump

Kit comes with heavy-duty water pump to prevent water pump failure.

INSTALLATION NOTES

1. The buyer is responsible for providing trained and experienced installation decision making with technical know-how to apply professional judgment that specifically applies to each individual installation.
2. Be sure to read and understand all available information including but not limited to instructions, warnings, sales terms, and warranties for the vehicle and all system components prior to attempting installation.
3. Disconnect the battery and drain engine coolant. Remove the fan and upper radiator hose, fan has right hand threads. (It is not necessary to remove the fan from the fan shroud, but care must be taken not to damage the radiator). Remove the damper bolt and clean any silicone or dirt from the damper pilot. Install the pump drive pulley (1) using bolt (2). Torque the bolt to 150-160 ft. lbs. Install set screws (3) into the pulley using a mild grade of Loc-tite and turn them in until they just make contact with the damper. Cross tighten them 1/8 turn at a time until you reach 35-40 **Inch lbs.**

NOTE: ALLEN BOLTS MUST BE TIGHTENED EVENLY

4. Disconnect the hoses from the radiator reservoir and remove the three bolts holding it in place. Install the main reservoir bracket with two 8mm x 12mm flange bolts. Install the reservoir brace over the ground wire located on the fender. Do not tighten at this time. Install the reservoir onto the main bracket as shown in the picture. Attach it to the brace on the fender with an OEM bolt and 8mm flange nut included in the kit. Install the 1" hose extension with clamps provided. The quick disconnect will need to have the plastic hose clamp removed in order to rotate the hose as shown. Replace the 3/8 hose with the one included in the kit and secure it with the loom clamp provided
5. Install new water pump (32) according to water pump installation sheet. Remove the clip holding the hose onto the radiator reservoir and remove the hose. Remove the power steering reservoir from the fan shroud and drain the fluid. Relocate the ABS module rearward with included hardware (20-24). Remove the top two bolts from the driver's side timing cover and install the studs (5). Remove the bolt from the idler on the passenger side, but leave the idler installed. Install the pump (18) and clutch onto the bracket (4) per manufacturer's instructions. Install the pump and bracket assembly onto the engine with the bottom bushing going over the existing idler location on the timing cover using bolt (7) and nuts (6). Tighten securely. Install the idlers (10) using bushings (11) and bolts (12). Install tensioner (8) using bolt (9). Install the belt (19) as shown in diagram.
6. Replace the upper radiator hose to its original location. Using hose hardware included (24-27) reroute the radiator reservoir hose. Approximately 1" can be cut from the nipple on the reservoir to let the 90-degree elbow go on further and gain more clearance to the pump. Install the power steering reservoir hose extension replace and refill the reservoir. Use hose clamp provided to secure the power steering hose to the bracket just below the clutch. Install the fan spacer and fan.

CAUTION: Before starting the engine, check to make certain no wires, hoses, etc. that may have been disturbed during installation do not come in contact with any hot or moving parts. Run the engine and check for proper belt tracking, adjust if necessary.



CW Mill Equipment Co., Inc.
14 Commerce Drive Sabetha, KS 66534
Phone: (785) 284-3454
Fax: (785) 284-3601
Email: brackets@cwmill.com
Website: www.cwkits.com

FMK49A-8WP

2017-2022 Ford F-250-F-350 Super Duty
6.2L V8 Gas w/ A/C

Requires SAE Two-Bolt 'A' Flange Pump, 8-Groove Clutch
Recommended 1.75 in³ or 8 gal. Pump w/ 12hp Restriction

NOTE: Must Use Rear Ported Pump

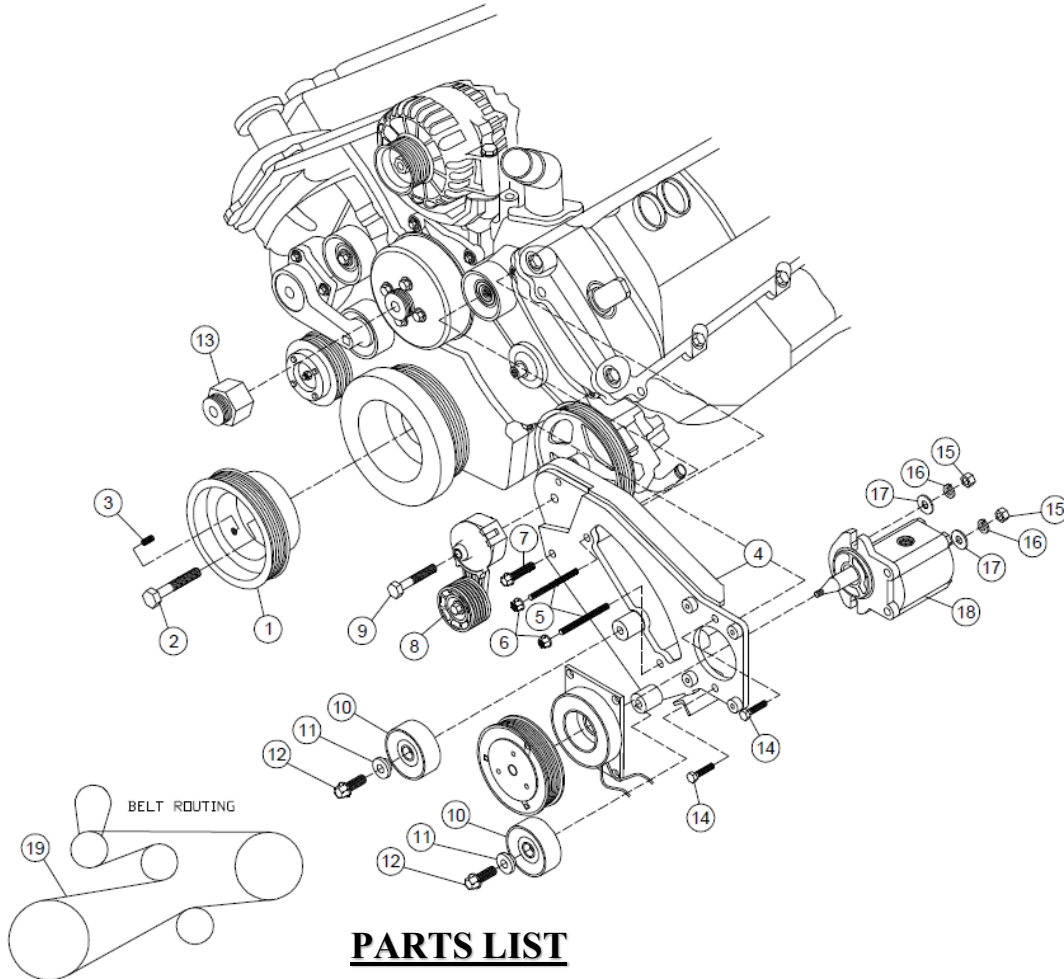

PARTS LIST

- | | |
|-----------------------------------|--|
| 1. FPC488 (1) | 19. 5080750 Dayco (1) |
| 2. 14mm x 120mm (1) | <u>ITEMS 20-23 (ABS BRAKE MODULE KIT) NOT SHOWN</u> |
| 3. 8mm x 16mm Set Screw (3) | 20. FMB 481 (Module Bracket) (1) |
| 4. FMP 48A-8 (1) | 21. FMB 482 (Module Bracket) (1) |
| 5. 8mm x 130mm Stud (2) | 22. 8mm x 20mm Flange Bolt (1) |
| 6. 8mm Flange Nut (2) | 23. 8mm Flange Nut (3) |
| 7. 8mm x 8mm Flange Bolt (1) | <u>ITEMS 24-27 (COOLANT HOSE KIT) NOT SHOWN</u> |
| 8. 89213-8 Tensioner (1) | 24. FMB 484 (Coolant Hose Extension) (1) |
| 9. 12mm x 65mm Short Head (1) | 25. 4200-16-16 Hose Barb (1) |
| 10. 89016 Dayco (2) | 26. #16 Hose Clamp (3) |
| 11. FMB 480 Alignment Bushing (2) | 27. #20 Hose Clamp (2) |
| 12. 10mm x 30mm Flange Bolt (2) | <u>ITEMS 28-31 (P.S. HOSE KIT) NOT SHOWN</u> |
| 13. FSK 6.8B (1) | 28. 4" of 3/4" Oil Hose (1) |
| 14. 3/8 x 1 1/2 Bolt (2) | 29. 4200-12-12 Hose Barb (1) |
| 15. 3/8 NC (2) | 30. #12 Hose Clamp (2) |
| 16. 3/8 LW (2) | 31. #20 Hose Clamp (1) |
| 17. 3/8 FW (2) | 32. 6.2L Heavy Duty Water Pump (1) |
| 18. Pump (sold separately) | |



CW Mill Equipment Co., Inc.
14 Commerce Drive Sabetha, KS 66534
Phone: (785) 284-3454
Fax: (785) 284-3601
Email: brackets@cwmill.com
Website: www.cwkits.com

FMK49A-8WP

2017-2022 Ford F-250-F-350 Super Duty
6.2L V8 Gas w/ A/C

Requires SAE Two-Bolt 'A' Flange Pump, 8-Groove Clutch
Recommended 1.75 in³ or 8 gal. Pump w/ 12hp Restriction

NOTE: Must Use Rear Ported Pump

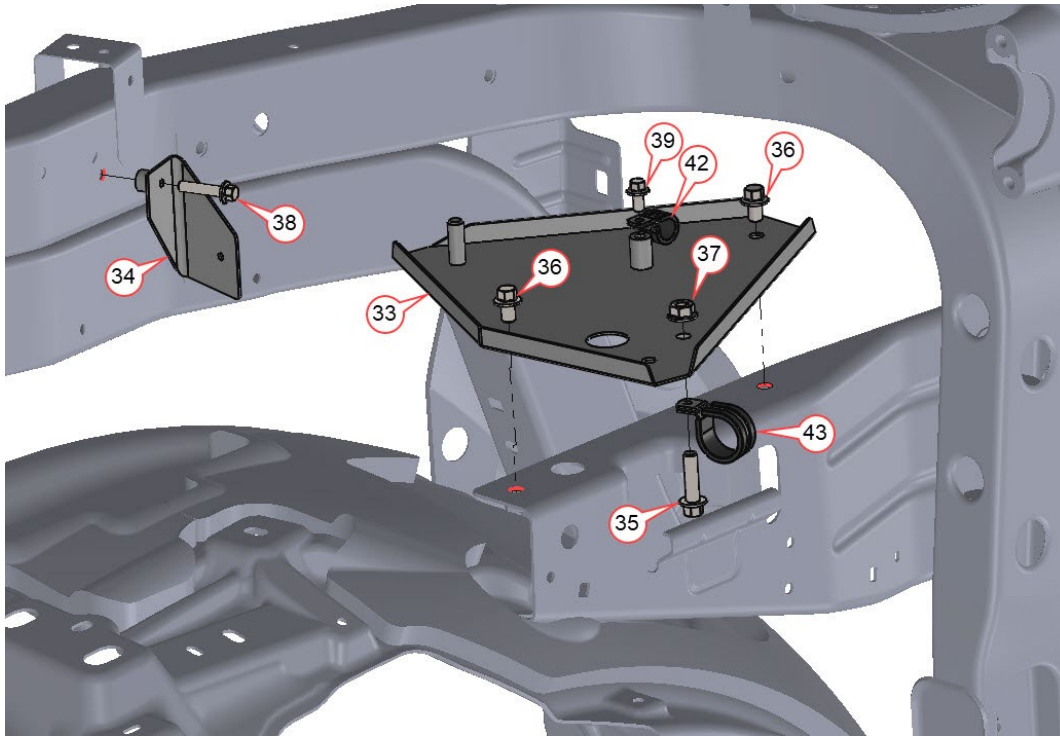

RESERVOIR RELOCATION PARTS LIST

- 33. FMB241 (1)
- 34. FMB242 (1)
- 35. 8X30MM FLG BOLT (1)
- 36. 8X12MM FLG BOLT (2)
- 37. 8MM FLG NUT (6)
- 38. 6X30MM FLG BOLT (1)
- 39. 6X12MM FLG BOLT (1)
- 40. 1" HEATER HOSE (10")
- 41. 3/8 HEATER HOSE (36")
- 42. #10 ADEL CLAMP (1)
- 43. #24 ADEL CLAMP (1)
- 44. #4 HOSE CLAMP (2)
- 45. #16 HOSE CLAMP (2)
- 46. #20 HOSE CLAMP (1)
- 47. 1" DBL HOSE BARB (1)



CW Mill Equipment Co., Inc.
14 Commerce Drive Sabetha, KS 66534
Phone: (785) 284-3454
Fax: (785) 284-3601
Email: brackets@cwmill.com
Website: www.cwkits.com

FMK49A-8WP

2017-2022 Ford F-250-F-350 Super Duty
6.2L V8 Gas w/ A/C

Requires SAE Two-Bolt 'A' Flange Pump, 8-Groove Clutch
Recommended 1.75 in³ or 8 gal. Pump w/ 12hp Restriction

NOTE: Must Use Rear Ported Pump



Disclaimer: (1.) Due to the custom nature and variation of all add-on systems of this type, no complete system kits are offered by the manufacturer, and any group of parts marketed as a kit is limited to only the individually defined parts in that specific kit. The system designer's rotating accessory components are not included, offered, or fully known by the manufacturer. In addition to the absence of the rotating accessory system, other potential components such as additional clamps, brackets, wear liners, hardware, or other items that may be required by the system designer must be identified and supplied by the actual system designer. (2.) Due to vehicle manufacturer's assembly tolerances, production changes, and installation variances, it is the buyer's responsibility to insure adequate clearance for all components including space for and safe location of the fan, radiator, all lines, and wires. Check for possible movement, vibration, friction points, heat exposure and/or shifting of any and all components such as hoses, wires, and all other components including those that may otherwise be considered non-moving and/or unaffected by the installation (3.) The buyer is responsible for the entire installation of a mounting kit as the mounting kit as the mounting kit is part of a custom process controlled by the buyer through their whole system design and directed installer as the installer evaluates, locates, routes, aligns, and tightens all components while determining if additional clamps, brackets, wear-liners, or other components may be required, beyond those included in the kit. Any additional items required, beyond those included in the kit, are to be provided at the expense of the buyer. (4.) the buyer is responsible for the development and communication of their whole system installation procedures, safety precautions, application, and use of the engine accessory mounting kit in their system, including efforts to maintain vehicle control and prevent pinch, wear, impact, and/or burn exposure on all hoses, wires, and other parts. (5.) The buyer is responsible for providing trained and experienced installation decision making with technical know-how to apply professional judgment that specifically applies to each individual installation. The buyers chosen installers must be qualified and experienced technicians that are familiar with the vehicle and accessory being mounted as well as the buyer's whole system design and installation procedures associated with the kit. (6.) The buyer is responsible for determining and achieving compliance to all regulatory issues that apply to the use of all products. (7.) The manufacturer reserves the right to make changes and/or improvements to any product at any time with or without notice.