



FMK4992V-8WP

2017-2022 Ford F-250-F-350 Super Duty
6.2L V8 Gas w/w/o A/C

Requires 8-Groove Pulley
Must use Vortec 92V Style Alternator

Kit Comes with Heavy-Duty Water Pump to Prevent Water Pump Failure

INSTALLATION NOTES

1. The buyer is responsible for providing trained and experienced installation decision making with technical know-how to apply professional judgment that specifically applies to each individual installation.
2. Be sure to read and understand all available information including but not limited to instructions, warnings, sales terms, and warranties for the vehicle and all system components prior to attempting installation.
3. Disconnect the battery and drain engine coolant. Remove the fan and upper radiator hose, fan has right hand threads. (It is not necessary to remove the fan from the fan shroud, but care must be taken not to damage the radiator). Remove the damper bolt and clean any silicone or dirt from the damper pilot. Install drive pulley (1) using bolt (2). Torque the bolt to 150-160 ft. lbs. Install set screws (3) into the pulley using a mild grade of Loctite and turn them in until they just make contact with the damper. Cross-tighten them 1/8 turn at a time until you reach 35-40 **Inch lbs.** **NOTE: (ALLEN BOLTS MUST BE TIGHTENED EVENLY).**
4. Disconnect the hoses from the radiator reservoir and remove the three bolts holding it in place. Install the main reservoir bracket (31) with bolts (34). Install the reservoir brace (32) with hardware (36) over the ground wire located on the fender. Do not tighten at this time. Install the reservoir onto the main reservoir bracket (31). As shown in the picture. Attach it to the brace (32) on the fender with an OEM bolt and nut (35). Install the 1" hose extension (38) with hardware provided. The quick disconnect will need to have the plastic hose clamp removed in order to rotate the hose as shown. Replace the 3/8" hose with the one included in this kit (39). Secure it with adel clamp (40).
5. Install new water pump (30) according to the water pump installation sheets. Remove the clip holding the hose onto the radiator reservoir and remove the hose. Remove the power steering reservoir from the fan shroud and drain the fluid. Relocate the ABS module rearward with included hardware (18-22). Remove the top two bolts from the driver's side timing cover and install the studs (5). Remove the bolt from the idler on the driver's side, but leave the idler installed. Install the alternator using bolts (13) and slide bushings (14) onto the bracket (4). Install the bracket assembly onto the engine with the bottom bushing going over the existing idler location on the timing cover using bolt (7) and nuts (6). Tighten securely. Install the idlers (8) using bushings (9) and bolts (10). Install tensioner (11) using bolt (12). Install the belt (15) as shown in diagram.
6. Replace the upper radiator hose to its original location. Using hose hardware included (23-26) reroute the radiator reservoir hose. Approximately 1" can be cut from the nipple on the reservoir to let the 90° elbow go on further and gain more clearance to the pump. Install the power steering reservoir hose extension (26-29) replace and refill the reservoir. Use hose clamp provided to secure the power steering hose to the bracket just below the alternator pulley. Install the fan spacer (16) and fan. Properly refill the coolant and reconnect the battery.

CAUTION: Before starting the engine, check to make certain no wires, hoses, etc. that may have been disturbed during installation do not come in contact with any hot or moving parts. Properly refill any fluids that may have been drained, check for leaks. Run the engine and check for proper belt tracking and clearance of any hoses, wires, etc. It is the installer's responsibility to correct/adjust any components, if necessary, before the vehicle is put into service.

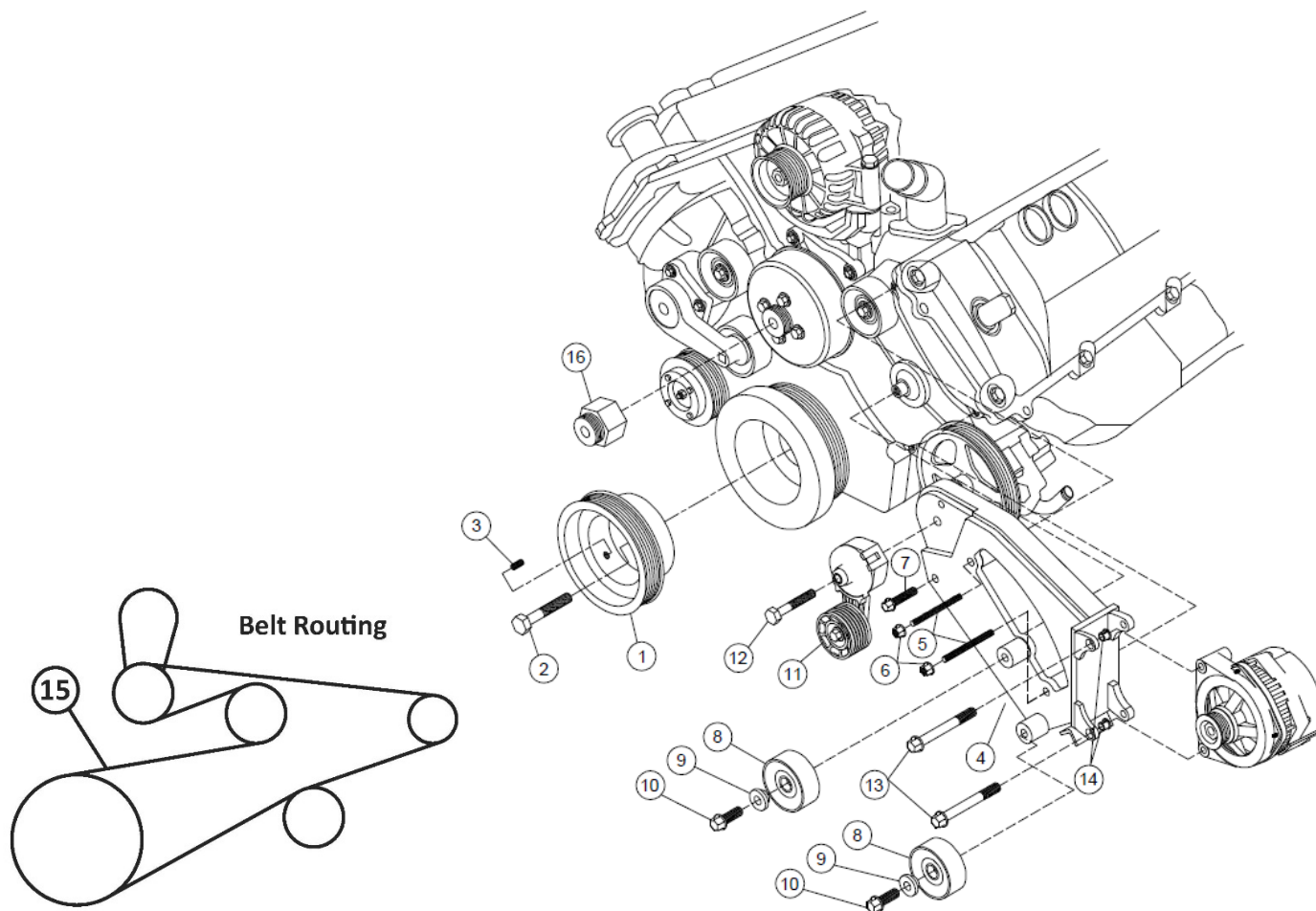

PARTS LIST

1. FPC488 (1)
2. 14mm x 120mm (1)
3. 8mm x 16mm Set Screw (3)
4. FMP 4892V-8 (1)
5. 8mm x 130mm Stud (2)
6. 8mm Flange Nut (2)
7. 8mm x 50mm Flange Bolt (1)
8. 89016 Dayco (2)
9. FMB 480 Alignment Bushing (2)
10. 10mm x 30mm Flange Bolt (2)
11. 89213-8 Tensioner (1)
12. 12mm x 65mm Short Head (1)
13. 10mm x 80mm Flange (2)
14. 1255-0090 Slide Bushing (2)
15. 5080745 Dayco (1)
16. FSK 6.8B (1)
17. Alternator (Not Included)

ITEMS 18-21 (ABS BRAKE MODULE KIT) NOT SHOWN

18. FMB 481 (Module Bracket) (1)
19. FMB 482 (Module Bracket) (1)
20. 8mm x 20mm Flange Bolt (1)
21. 8mm Flange Nut (3)

ITEMS 22-25 (COOLANT HOSE KIT) NOT SHOWN

22. FMB 484 (Coolant Hose Extension) (1)
23. 4200-16-16 Hose Barb (1)
24. #16 Hose Clamp (3)
25. #20 Hose Clamp (2)

ITEMS 26-29 (P.S. HOSE KIT) NOT SHOWN

26. 4" of 3/4" Oil Hose (1)
27. 4200-12-12 Hose Barb (1)
28. #12 Hose Clamp (2)
29. #20 Hose Clamp (1)
30. 6.2L Heavy Duty Water Pump (1)

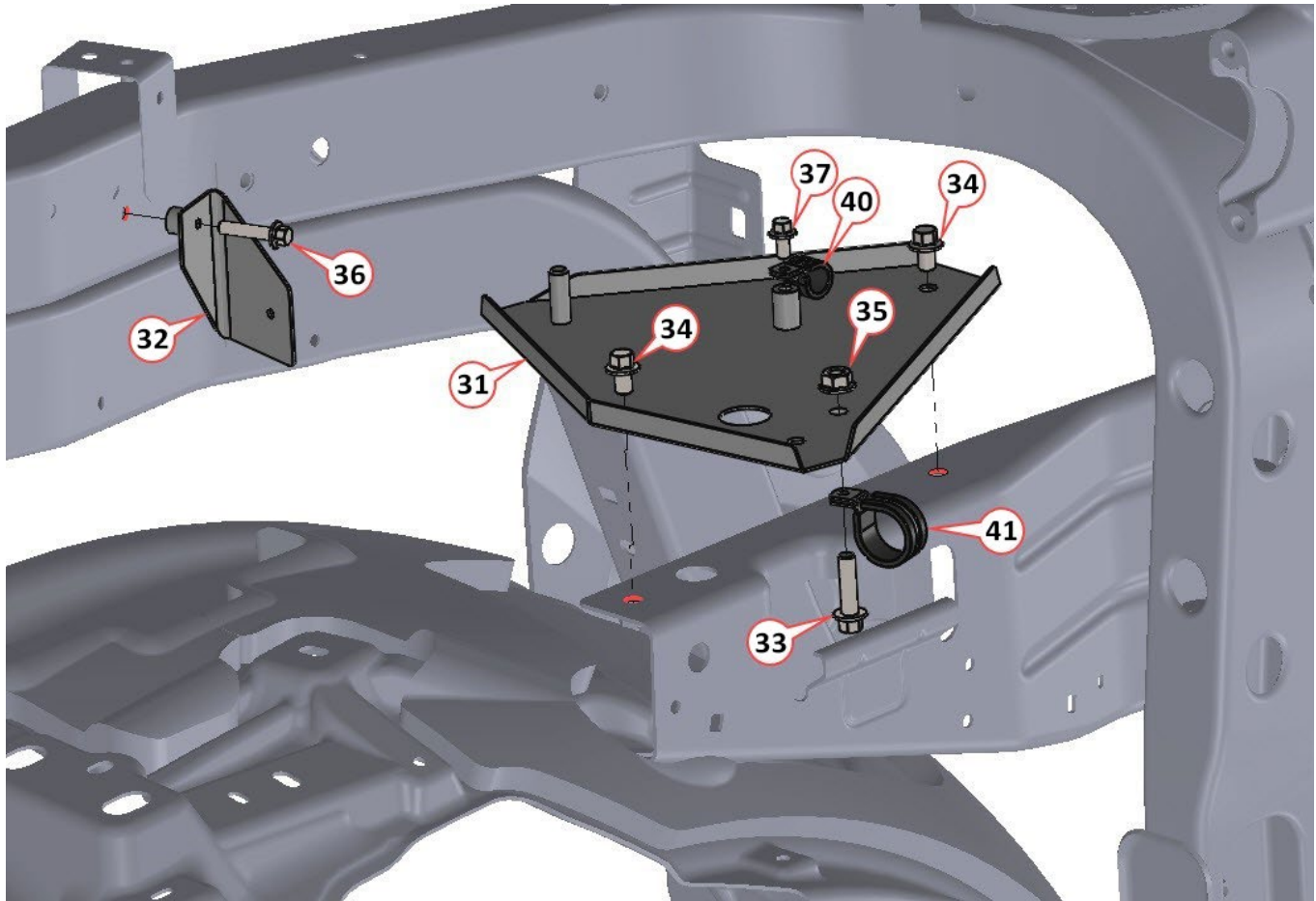

Reservoir Relocation Parts List							
Item	Part Number	Description	Qty.	Item	Part Number	Description	Qty.
31	FMB241	Main Reservoir Bracket	1	39	1018234	3/8" Heater Hose	36"
32	FMB242	Reservoir Brace	1	40	1005113	#10 Adel Clamp	1
33	1013349	M8-1.25 x 30mm 10.9Gr Hex Flg. Bolt	1	41	1021296	#24 Adel Clamp	1
34	1011623	M8-1.25 x 12mm 10.9Gr Hex Flg. Bolt	2	42	1016347	#4 Hose Clamp	2
35	1013333	M8-1.25 10.9Gr Hex Flg. Nut	6	43	1015525	#16 Hose Clamp	2
36	1016342	M6-1.0 x 30mm 10.9Gr Hex Flg. Bolt	1	44	1009294	#20 Hose Clamp	1
37	1016340	M6-1.0 x 12mm 10.9Gr Hex Flg. Bolt	1	45	1008593	1" Double Hose Barb	1
38	1007564	1" Heater Hose	10"				

CW **CW Mill Equipment Co., Inc.**
14 Commerce Drive Sabetha, KS 66534
Phone: (785) 284-3454
Fax: (785) 284-3601
Email: brackets@cwmill.com
Website: www.cwkits.com

MOUNTING KITS

FMK4992V-8WP

2017-2022 Ford F-250-F-350 Super Duty
6.2L V8 Gas w/-w/o A/C

Requires 8-Groove Pulley
Must use Vortec 92V Style Alternator



Reservoir Picture



CW Mill Equipment Co., Inc.
 14 Commerce Drive Sabetha, KS 66534
 Phone: (785) 284-3454
 Fax: (785) 284-3601
 Email: brackets@cwmill.com
 Website: www.cwkits.com

FMK4992V-8WP

2017-2022 Ford F-250-F-350 Super Duty
 6.2L V8 Gas w/-w/o A/C

Requires 8-Groove Pulley
Must use Vortec 92V Style Alternator

INSTALLER NOTES / DISCLAIMER

CW Mill Equipment Co., Inc. Mounting Kit and Mounting Kit Component Disclaimer: (1.) Due to the custom nature and variation of all add-on systems of this type, no complete system kits are offered by the manufacturer, and any group of parts marketed as a kit is limited to only the individually defined parts in that specific kit. The system designer's rotating accessory components are not included, offered, or fully known by the manufacturer. In addition to the absence of the rotating accessory system, other potential components such as additional clamps, brackets, wear liners, hardware, or other items that may be required by the system designer must be identified and supplied by the actual system designer. (2.) Due to vehicle manufacturer's assembly tolerances, production changes, and installation variances, it is the buyer's responsibility to ensure adequate clearance for all components including space for and safe location of the fan, radiator, all lines, and wires. Check for possible movement, vibration, friction points, heat exposure and/or shifting of any and all components such as hoses, wires, and all other components including those that may otherwise be considered non-moving and/or unaffected by the installation (3.) The buyer is responsible for the entire installation of a mounting kit as the mounting kit is part of a custom process controlled by the buyer through their whole system design and directed installer as the installer evaluates, locates, routes, aligns, and tightens all components while determining if additional clamps, brackets, wear-liners, or other components may be required, beyond those included in the kit. Any additional items required, beyond those included in the kit, are to be provided at the expense of the buyer. (4.) The buyer is responsible for the development and communication of their whole system installation procedures, safety precautions, application, and use of the engine accessory mounting kit in their system, including efforts to maintain vehicle control and prevent pinch, wear, impact, and/or burn exposure on all hoses, wires, and other parts. (5.) The buyer is responsible for providing trained and experienced installation decision making with technical know-how to apply professional judgment that specifically applies to each individual installation. The buyers chosen installers must be qualified and experienced technicians that are familiar with the vehicle and accessory being mounted as well as the buyer's whole system design and installation procedures associated with the kit. (6.) The buyer is responsible for determining and achieving compliance to all regulatory issues that apply to the use of all products. (7.) The manufacturer reserves the right to make changes and/or improvements to any product at any time with or without notice.