



CMK13292V-I6

2020-2024 Chevrolet Silverado 1500
2020-2024 GMC Sierra 1500
5.3L V8 Gas w/ A/C, w/o Dual Alternators

Requires 6-Groove Pulley
For use w/ GM 92V Style Alternator

On 2020 and newer model year trucks, either, GM part number 12725728 will need to be purchased and replace the OEM water pump. And/or the OEM water pump can be sent back to CW Mill Equipment Co., Inc. to be machined for this mounting kit to work.

INSTALLATION NOTES

1. The buyer is responsible for providing trained and experienced installation decision making with technical know-how to apply professional judgment that specifically applies to each individual installation.
2. Be sure to read and understand all available information including but not limited to instructions, warnings, sale terms, and warranties for the vehicle and all system components prior to attempting installation.
3. Disconnect the negative battery cable and remove the air duct from the intake to the air filter box. It will not be reused. Remove the OEM fan/alternator belt. It is a stretch-fit belt that will not be reused. Cutting the belt is the easiest way to remove it.
4. Install tensioner bracket (10) with bolt (11) at location [A]. Torque bolt to 25 ft/lbs. Install tensioner (8) with bolt (9). Torque bolt to 20 ft/lbs.
5. Remove the OEM alternator bolt (5) at location [B] and loosen the alternator bolt at location [C]. Swing the alternator up in a clockwise direction if facing towards the front of the engine, and install the main bracket (1) at location [B] with the OEM alternator bolt (5) that was removed. Do not tighten yet. Attach the OEM alternator to the main bracket (1) with bolt (4) loosely. Install rear brace (3) with bolts (7) into the cylinder head at location [D] and bolts (6) into the main bracket (1). Do not tighten yet. Tighten the OEM alternator bolt first to 25 ft/lbs. Then alternator-main bracket bolt (4) to 30 ft/lbs. Evenly tighten all rear brace bolts, then torque to 15 ft/lbs.
6. Install the auxiliary alternator to the main bracket (1) using bolt (26). Remove the inside alternator bolt at location [C]. Install alternator brace (29) with flat washer (30) and bolt (31) at the OEM alternator location [C], and bolt (27) with nut (28) to the auxiliary alternator. Torque bolts to 25 ft/lbs. Install grooved idler (12) with alignment bushing (13) and bolt (14) onto the main bracket (1). Torque to 25 ft/lbs. Install smooth idler (15), alignment bushing (16) and bolt (17) at location [E]. Torque bolt to 15 ft/lbs.
7. Install belt (25) and route it as shown in the illustration. Install 90° rubber elbow assembly (20) onto the intake inlet with the bellows to the air filter side. Install the 3-1/2" to 4" coupler (21) onto the air filter box with clamps (22,23). Install the steel air duct tube (24) into the coupler and the elbow. Position it so the 5/8" nipple is pointing at approximately a 45° angle upward and rearward. Tighten all clamps securely. Remove the PCV hose from the passenger side valve cover and install one end of the 5/8" oil hose (18) there and the other end to the nipple on the air duct with clamps (19). Tighten hose clamps securely.

NOTE: The OEM A/C line attached to the radiator support may need to slide to the passenger side slightly and secured to gain clearance to the add on A/C compressor.

CAUTION: Before starting the engine, check to make certain no wires, hoses, etc. that may have been disturbed during installation do not come in contact with any hot or moving parts. Run the engine and check for proper belt tracking, adjust if necessary.

CMK13292V-I6

2020-2024 Chevrolet Silverado 1500
 2020-2024 GMC Sierra 1500
 5.3L V8 Gas w/ A/C, w/o Dual Alternators

Requires 6-Groove Pulley
 For use w/ GM 92V Style Alternator

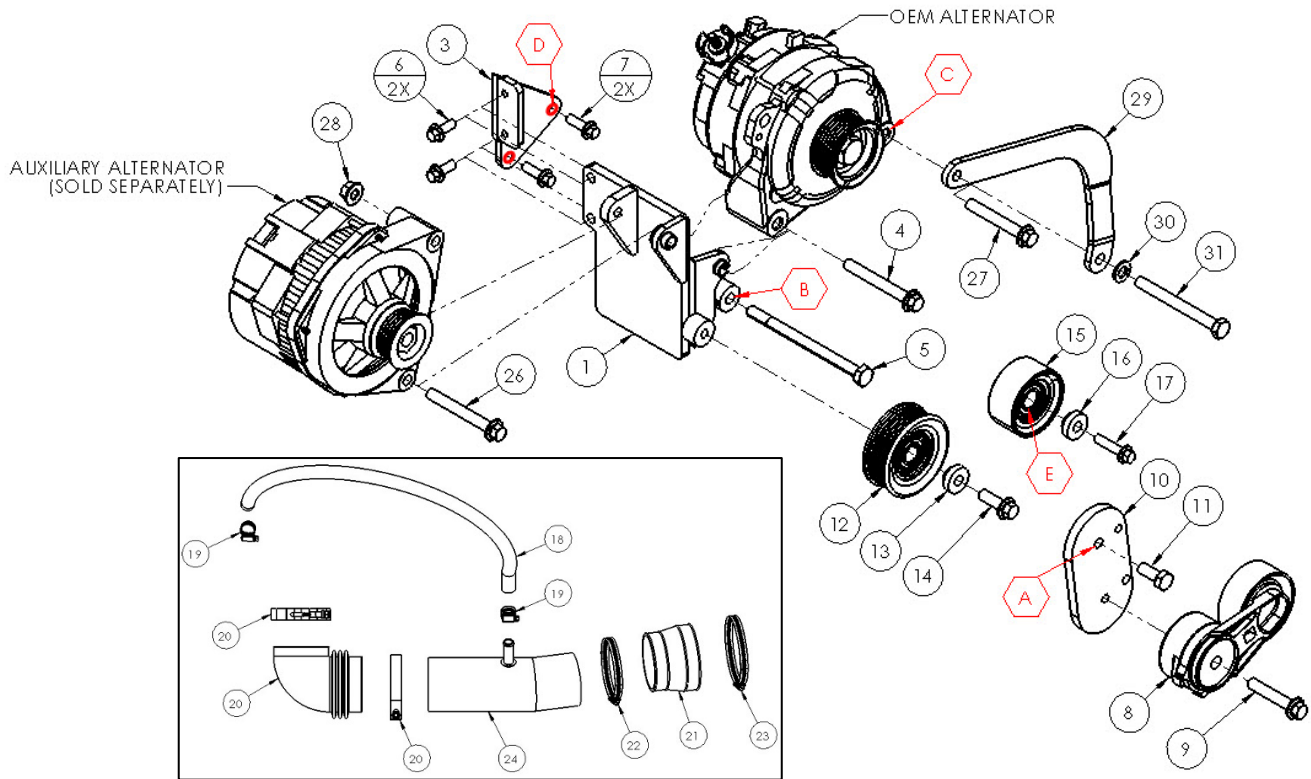

Hose Assembly (18-24) Top View

PARTS LIST							
Item	Part Number	Description	Qty.	Item	Part Number	Description	Qty.
Main Bracket				Air Intake Assembly			
1	CMB13292V	Main Bracket	1	18	1010299	5/8" Oil Hose	25"
2	1011888A	M14 Slide Bushing (Installed)	2	19	1018276	#8 Hose Clamps	2
Main Bracket Rear Support Brace				20	1018282	90° Air Duct Assembly (CMK132: 3½")	1
3	CMB132SD508-2	Main Bracket Rear Support Brace	1	21	1018281	3-1/2" to 4" Coupler	1
Main Bracket Mounting Hardware				22	1016326	#56 Hose Clamp	1
4	1006928	M10-1.5 x 80mm Flange Bolt	1	23	1016327	#64 Hose Clamp	1
5	N/A	OEM Alternator Bolt	1	24	C132AD	Custom Steel Tube	1
Main Bracket Rear Support Brace Mounting Hardware				Belt			
6	1013329	M8-1.25 x 20mm Flange Bolt	2	25	K061037	Gates 6-Groove 103.7" Belt	1
7	1011887	M8-1.25 x 25mm Flange Bolt	2	Auxiliary Alternator Mounting Hardware			
Tensioner Assembly				26	1006927	M10-1.5 x 80mm Flange Bolt	1
8	89396	Dayco Tensioner	1	27	1016343	M10-1.5 x 70mm Flange Bolt	1
9	1018225	M10-1.5 x 55mm Flange Bolt	1	28	1018204	M10-1.5 Flange Nut	1
Tensioner Bracket and Mounting Hardware				Auxiliary Alternator L Brace and Mounting Hardware			
10	CMB132SD508-3	Tensioner Bracket	1	29	CMK13292V-001	Alternator L Brace	1
11	1004000M	M10-1.5 x 25mm Bolt (.180" M)	1	30	1003748	M10 Flat Washer	1
Grooved Idler Pulley Assembly				31	1003981	M10-1.25 x 100mm Bolt	1
12	89051	Dayco Grooved Idler Pulley	1				
13	FMB480	Machined Idler Alignment Bushing	1				
14	1006927	M10-1.5 x 30mm Flange Bolt	1				
Smooth Idler Pulley Assembly							
15	TIPCS2.5	Custom Smooth Idler Pulley	1				
16	FMB480	Machined Idler Alignment Bushing	1				
17	1018224	M8-1.25 x 35mm Flange Bolt	1				

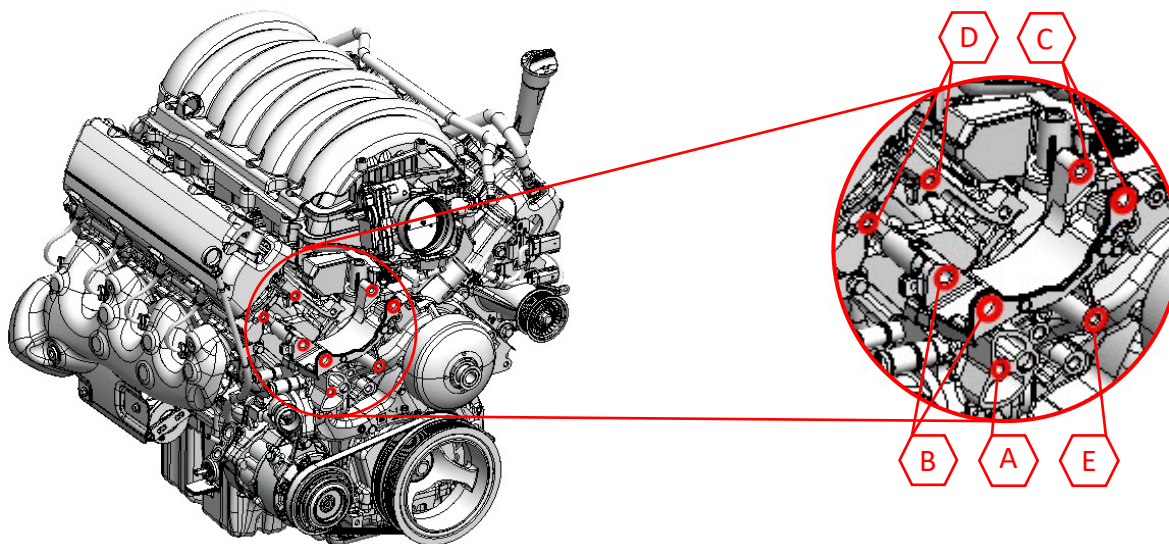

Mounting Locations Details

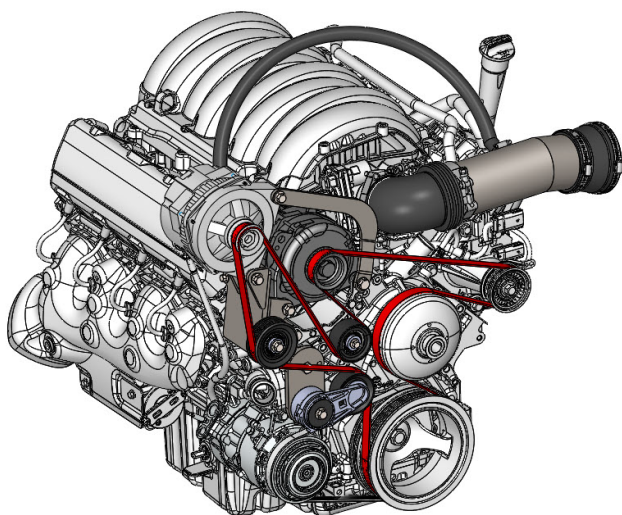

Kit Assembly

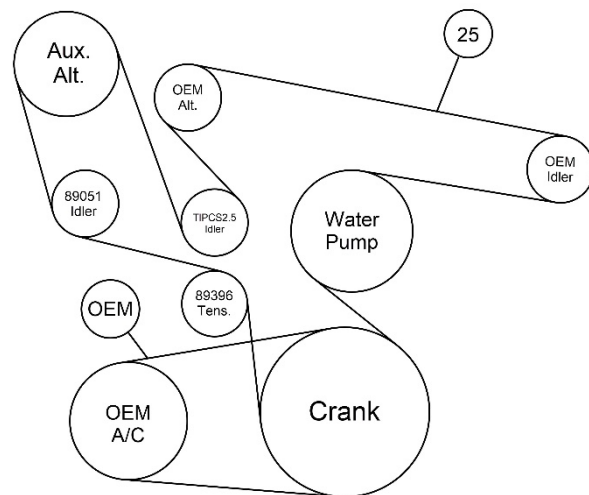

Belt Routing (25)

Disclaimer: (1.) Due to the custom nature and variation of all add-on systems of this type, no complete system kits are offered by the manufacturer, and any group of parts marketed as a kit is limited to only the individually defined parts in that specific kit. The system designer's rotating accessory components are not included, offered, or fully known by the manufacturer. In addition to the absence of the rotating accessory system, other potential components such as additional clamps, brackets, wear liners, hardware, or other items that may be required by the system designer must be identified and supplied by the actual system designer. (2.) Due to vehicle manufacturer's assembly tolerances, production changes, and installation variances, it is the buyer's responsibility to ensure adequate clearance for all components including space for and safe location of the fan, radiator, all lines, and wires. Check for possible movement, vibration, friction points, heat exposure and/or shifting of any and all components such as hoses, wires, and all other components including those that may otherwise be considered non-moving and/or unaffected by the installation (3.) The buyer is responsible for the entire installation of a mounting kit as the mounting kit is part of a custom process controlled by the buyer through their whole system design and directed installer as the installer evaluates, locates, routes, aligns, and tightens all components while determining if additional clamps, brackets, wear-liners, or other components may be required, beyond those included in the kit. Any additional items required, beyond those included in the kit, are to be provided at the expense of the buyer. (4.) The buyer is responsible for the development and communication of their whole system installation procedures, safety precautions, application, and use of the engine accessory mounting kit in their system, including efforts to maintain vehicle control and prevent pinch, wear, impact, and/or burn exposure on all hoses, wires, and other parts. (5.) The buyer is responsible for providing trained and experienced installation decision making with technical know-how to apply professional judgment that specifically applies to each individual installation. The buyers chosen installers must be qualified and experienced technicians that are familiar with the vehicle and accessory being mounted as well as the buyer's whole system design and installation procedures associated with the kit. (6.) The buyer is responsible for determining and achieving compliance to all regulatory issues that apply to the use of all products. (7.) The manufacturer reserves the right to make changes and/or improvements to any product at any time with or without notice.