



# FLMK80SD508-I8

2015-2024 Freightliner M2 Business Class  
8.9L Cummins ISL-9 Diesel w/ A/C

Requires 8-Groove, 119mm Diameter Clutch  
For use w/ TM13 TM15 or TM16 Ear Mount Compressor

## INSTALLATION NOTES

---

1. The buyer is responsible for providing trained and experienced installation decision making with technical know-how to apply professional judgment that specifically applies to each individual installation.
2. Be sure to read and understand all available information including but not limited to instructions, warnings, sales terms, and warranties for the vehicle and all system components prior to attempting installation.
3. Disconnect negative battery cables. Remove the cable ties securing the air line going to the air clutch from the wire harnesses running in front of the head. Re-route the air line to the front side of wire harnesses in front of the head by removing and re-installing at the fitting on the firewall. This is to allow wiring to set back closer to engine for better clearance. Re-secure wire harnesses using cable ties (20).
4. Remove the serpentine belt. Remove the factory idler pulley and spacer located at location [A] above the water pump. This will be re-used. Remove the four bolts and hose standoff from the radiator support on the driver side of engine.
5. Install mounting plate (1) using bolts (3,4), lock washers (5), and factory hose standoff on top of radiator support bracket. Re-connect overflow hose to standoff using zip tie (18). Additional retainers for overflow hose may need cut to prevent kinks. Do not tighten bolts. Install idler mount (6) using bolts (7) with flat washers (9) and lock washers (8). Then, bolt (15), OEM idler (13), and bushing (14) at location [A]. Once all bolts are finger tight, first torque bolt (13), then torque mounting plate bolts (3,4). Once this is done, tighten the other idler bracket bolts (7). Install idler (10) to idler bracket (6) using bolt (12) and spacer (11).
6. Install the auxiliary A/C compressor using bolts (16,17), nuts (18) and slide bushings (2). Install belt (19) according to the belt diagram below. Check all clearances to prevent damage to wiring, air lines, etc. Reconnect battery cables.

**CAUTION:** Before starting the engine. Check to make certain no wires, hoses, etc. that may have been disturbed during installation do not come in contact with any hot or moving parts. Run the engine and check for proper belt tracking, adjust if necessary.

Disclaimer: (1.) Due to the custom nature and variation of all add-on systems of this type, no complete system kits are offered by the manufacturer, and any group of parts marketed as a kit is limited to only the individually defined parts in that specific kit. The system designer's rotating accessory components are not included, offered, or fully known by the manufacturer. In addition to the absence of the rotating accessory system, other potential components such as additional clamps, brackets, wear liners, hardware, or other items that may be required by the system designer must be identified and supplied by the actual system designer. (2.) Due to vehicle manufacturer's assembly tolerances, production changes, and installation variances, it is the buyer's responsibility to ensure adequate clearance for all components including space for and safe location of the fan, radiator, all lines, and wires. Check for possible movement, vibration, friction points, heat exposure and/or shifting of any and all components such as hoses, wires, and all other components including those that may otherwise be considered non-moving and/or unaffected by the installation (3.) The buyer is responsible for the entire installation of a mounting kit as the mounting kit is part of a custom process controlled by the buyer through their whole system design and directed installer as the installer evaluates, locates, routes, aligns, and tightens all components while determining if additional clamps, brackets, wear-liners, or other components may be required, beyond those included in the kit. Any additional items required, beyond those included in the kit, are to be provided at the expense of the buyer. (4.) The buyer is responsible for the development and communication of their whole system installation procedures, safety precautions, application, and use of the engine accessory mounting kit in their system, including efforts to maintain vehicle control and prevent pinch, wear, impact, and/or burn exposure on all hoses, wires, and other parts. (5.) The buyer is responsible for providing trained and experienced installation decision making with technical know-how to apply professional judgment that specifically applies to each individual installation. The buyers chosen installers must be qualified and experienced technicians that are familiar with the vehicle and accessory being mounted as well as the buyer's whole system design and installation procedures associated with the kit. (6.) The buyer is responsible for determining and achieving compliance to all regulatory issues that apply to the use of all products. (7.) The manufacturer reserves the right to make changes and/or improvements to any product at any time with or without notice.

# FLMK80SD508-I8

2015-2024 Freightliner M2 Business Class  
 8.9L Cummins ISL-9 Diesel w/ A/C

Requires 8-Groove, 119mm Diameter Clutch  
 For use w/ TM13 TM15 or TM16 Ear Mount Compressor

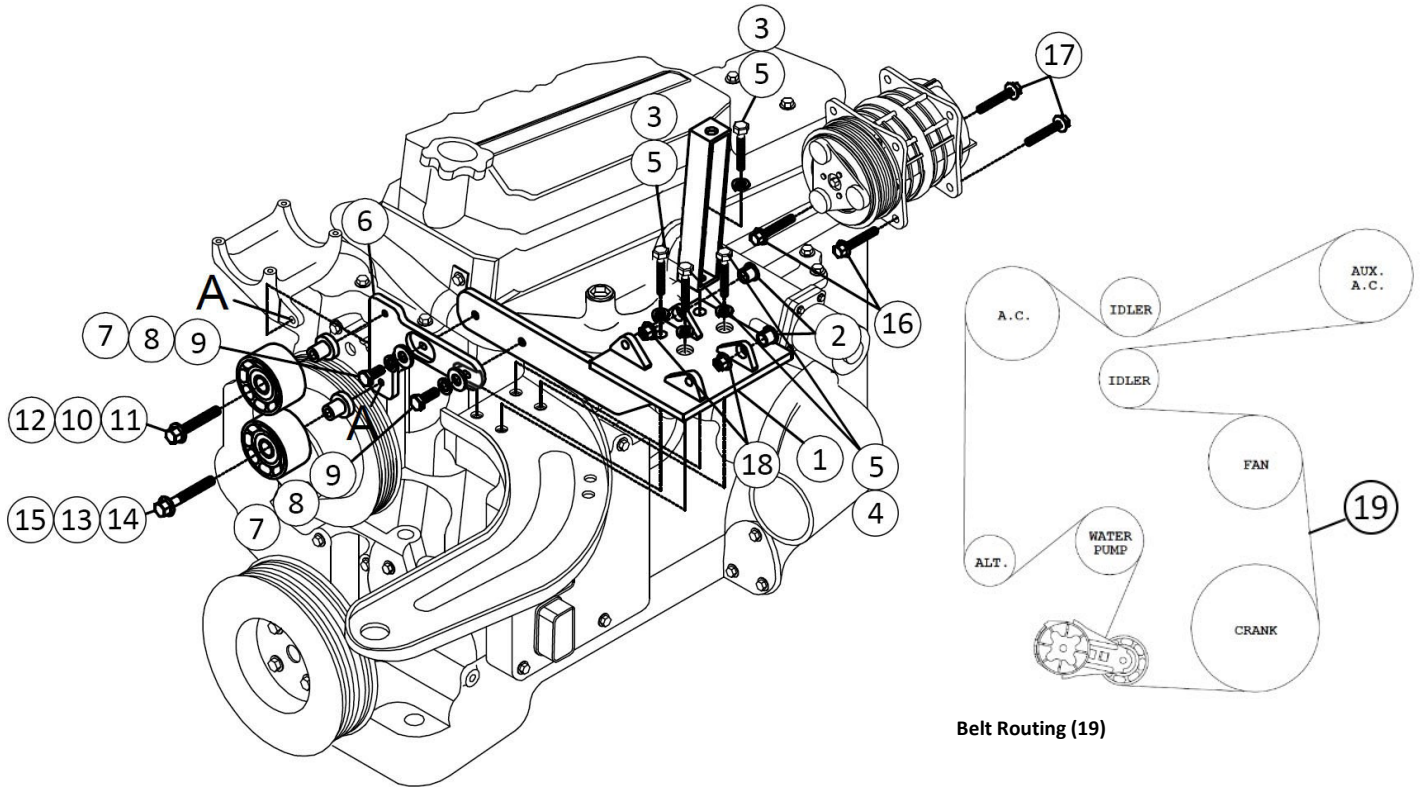

Belt Routing (19)

PARTS LIST							
Item	Part Number	Description	Qty.	Item	Part Number	Description	Qty.
<b>Main Bracket</b>				<b>Smooth Idler Pulley Assembly (Group 2)</b>			
1	FLMP80SD508-I8	Main Bracket	1	13	N/A	OEM Smooth Idler Pulley	1
2	1011888A	M14 Slide Bushing (Installed)	2	14	CMB741	Machined Idler Bushing	1
<b>Main Bracket Mounting Hardware</b>				15	1016343	M10-1.5 x 70mm Flange Bolt	1
3	1005594	M10-1.5 x 65mm Bolt	2	<b>Auxiliary A/C Compressor Mounting Hardware</b>			
4	1007594	M10-1.5 x 60mm Bolt	2	16	1006927	M10-1.5 x 30mm Flange Bolt	2
5	1003822	M10 Lock Washer	4	17	1006933	M10-1.5 x 40mm Flange Bolt	2
<b>Idler Assemblies Mount Plate</b>				18	1018204	M10-1.5 Flange Nut	2
6	FLMB801	Idler Assemblies Mount Plate	1	<b>Belt</b>			
<b>Idler Assemblies Mount Plate Mounting Hardware</b>				19	5081223	Dayco 8-Groove 122.3" Belt	1
7	1004000	M10-1.5 x 25mm Bolt	2	<b>Zip Ties (Not Shown)</b>			
8	1003822	M10 Lock Washer	2	20	1005413	7" Zip Tie	6
9	1003748	M10 Flat Washer	2	21	1005417	15" Zip Tie	1
<b>Smooth Idler Pulley Assembly (Group 1)</b>							
10	89101	Dayco Smooth Idler Pulley	1				
11	CMB741	Machined Idler Bushing	1				
12	1006934	M10-1.5 x 50mm Flange Bolt	1				