

INSTALLATION NOTES

1. Be sure to read and understand all available information including but not limited to instructions, warnings, sale terms, and warranties for the vehicle and all system components prior to attempting installation.
2. Remove negative cables and wires on batteries. Remove passenger side inner fender, remove fan belt.
3. Remove alternator, bracket, and lifting lug.
4. Cut the upper radiator hose as shown and install bet tube (22) with hose clamps (23).
5. Install new alternator bracket (1) with bolts (9). Install OEM alternator and angle bracket (3) that matches alternator bolt pattern with bolts (11) and washers (12) & (13). Use washers (12) between bracket (3) and alternator. Install wire harness support to keep harness off of alternator. Leave bolts (11) loose for now.
6. Install accessory drive plate (4) with bolts (8) & (10). Secure bolts (10), snug bolts (8), tighten bolts (11) adjust harness support to keep harness off of alternator and tighten bolts (8).
7. Install accessory alternator to plate (4) with bolts provided. Note: Inside bushing is shorter and the bolt head is machined for belt clearance.
8. Install flat idler (7) with bushing (5) and bolt (10) at lower location the furthest from engine. Install grooved idler (6) with bushing (5) and bolt (10). Snap rings towards radiator.
9. Secure wire harness to water line near fan pulley using clamps (14) & (15) and hardware (16) - (19). Pull slack from harness to keep it off of alternator. Keep clamps away from fan pulley. Push harness through OE clamp toward driver side to keep away from fan pulley if necessary.
10. Install belt (20) as shown in diagram, check for any belt interference.
11. Install negative battery cables, start and check belt tracking. Install inner fender.

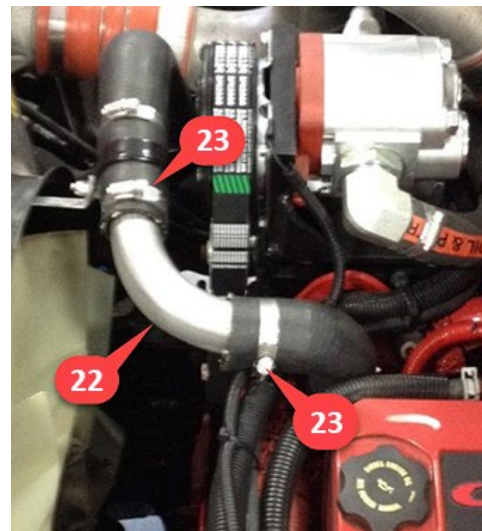

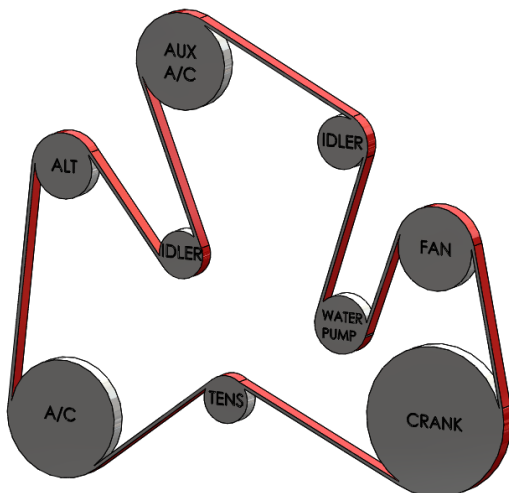

CW Mill Equipment Co., Inc.

14 Commerce Drive Sabetha, KS 66534

Phone: (785) 284-3454

Fax: (785) 284-3601

Email: brackets@cwmill.com

Website: www.cwkits.com

IMK3392V-I8

2016-2024 International Durastar 4300-4400

6.7L I6 Cummins ISB Diesel w/-w/o AC

Requires 8-Groove Pulley
For Use w/ Vortec 92V Alternator

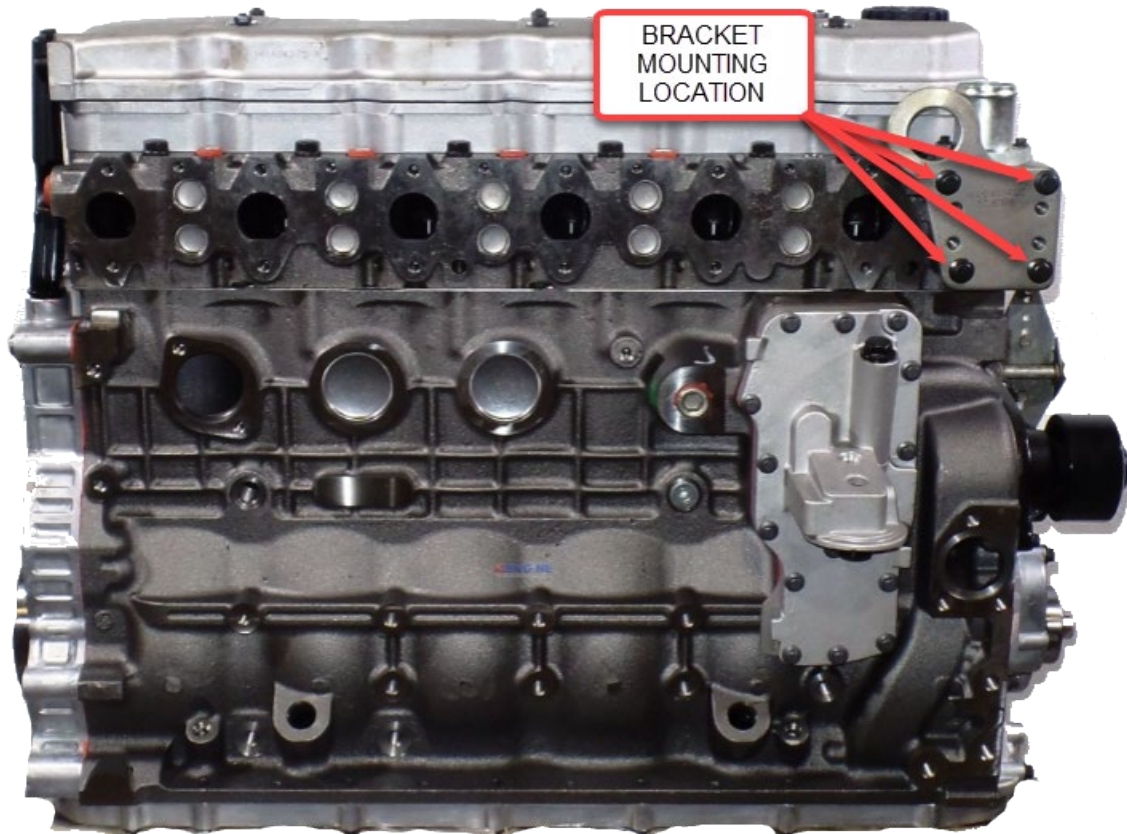

PARTS LIST

- | | |
|-----------------------------|---------------------------------|
| 1. IMB601 (1) | 13. 10mm Lock Washer (2) |
| 2. IMB602 (1) | 14. 16mm Clamp (1) |
| 3. IMB603 (1) | 15. 24mm Clamp (1) |
| 4. IMB604 (1) | 16. 1/4 x 1 Bolt (1) |
| 5. IMB605 (2) | 17. 1/4 Flat Washer (1) |
| 6. 8 Groove Idler (1) | 18. 1/4 Lock Washer (1) |
| 7. Flat Idler (1) | 19. 1/4 Nut (1) |
| 8. 10 x 20mm Flg Bolt (2) | 20. 5081305 Belt (1) |
| 9. 10 x 40mm Flg Bolt (4) | 21. 10 x 80mm Bolt (2) |
| 10. 10 x 50mm Flg Bolt (6) | <u>NOT SHOWN (22-23)</u> |
| 11. 10 x 110mm Flg Bolt (2) | 22. IMB33-01 Steel Tube (1) |
| 12. 3/8" Flat Washer (3) | 23. #28 Hose Clamp (3) |



CW Mill Equipment Co., Inc.

14 Commerce Drive Sabetha, KS 66534

Phone: (785) 284-3454

Fax: (785) 284-3601

Email: brackets@cwmill.com

Website: www.cwkits.com

IMK3392V-I8

2016-2024 International Durastar 4300-4400

6.7L I6 Cummins ISB Diesel w/-w/o AC

Requires 8-Groove Pulley
For Use w/ Vortec 92V Alternator

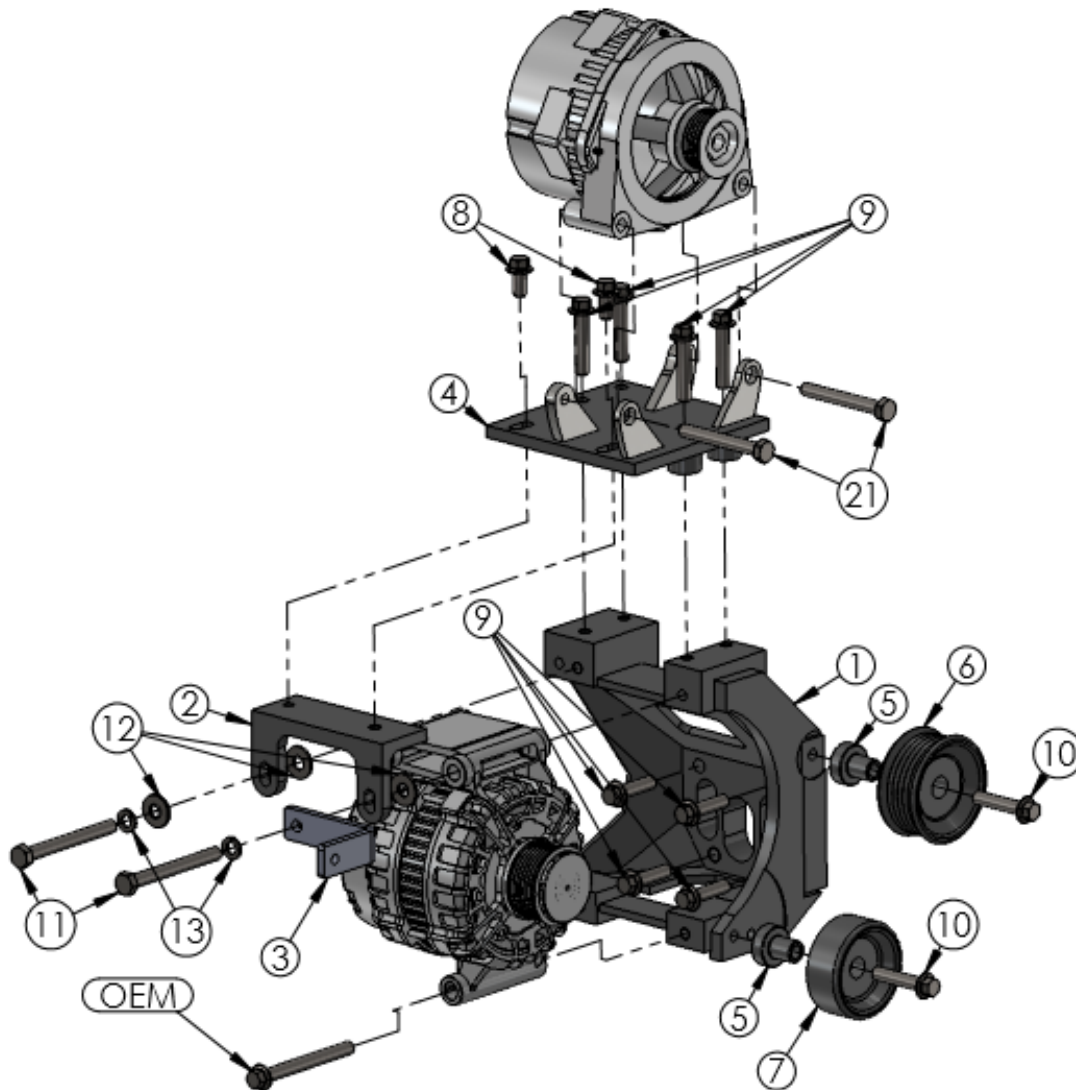

Disclaimer: (1.) Due to the custom nature and variation of all add-on systems of this type, no complete system kits are offered by the manufacturer, and any group of parts marketed as a kit is limited to only the individually defined parts in that specific kit. The system designer's rotating accessory components are not included, offered, or fully known by the manufacturer. In addition to the absence of the rotating accessory system, other potential components such as additional clamps, brackets, wear liners, hardware, or other items that may be required by the system designer must be identified and supplied by the actual system designer. (2.) Due to vehicle manufacturer's assembly tolerances, production changes, and installation variances, it is the buyer's responsibility to insure adequate clearance for all components including space for and safe location of the fan, radiator, all lines, and wires. Check for possible movement, vibration, friction points, heat exposure and/or shifting of any and all components such as hoses, wires, and all other components including those that may otherwise be considered non-moving and/or unaffected by the installation (3.) The buyer is responsible for the entire installation of a mounting kit as the mounting kit is part of a custom process controlled by the buyer through their whole system design and directed installer as the installer evaluates, locates, routes, aligns, and tightens all components while determining if additional clamps, brackets, wear-liners, or other components may be required, beyond those included in the kit. Any additional items required, beyond those included in the kit, are to be provided at the expense of the buyer. (4.) the buyer is responsible for the development and communication of their whole system installation procedures, safety precautions, application, and use of the engine accessory mounting kit in their system, including efforts to maintain vehicle control and prevent pinch, wear, impact, and/or burn exposure on all hoses, wires, and other parts. (5.) The buyer is responsible for providing trained and experienced installation decision making with technical know-how to apply professional judgment that specifically applies to each individual installation. The buyers chosen installers must be qualified and experienced technicians that are familiar with the vehicle and accessory being mounted as well as the buyer's whole system design and installation procedures associated with the kit. (6.) The buyer is responsible for determining and achieving compliance to all regulatory issues that apply to the use of all products. (7.) The manufacturer reserves the right to make changes and/or improvements to any product at any time with or without notice.