

INSTALLATION NOTES

1. Be sure to read and understand all available information including but not limited to instructions, warnings, sale terms, and warranties for the vehicle and all system components prior to attempting installation.
2. Disconnect negative cables on batteries. Remove passenger side inner fender, remove fan belt. Drain enough antifreeze to remove upper radiator hose.
3. Remove alternator, bracket, and lifting lug.
4. Cut the upper radiator hose as shown and install bent tube (18) with hose clamps (19).
5. Install new alternator bracket (1) with bolts (9). Install OEM alternator and angle bracket (3) that matches alternator bolt pattern with bolts (11) and washers (12) & (13). Use washers (12) between bracket (3) and alternator. Install new upper radiator hose support (3) reusing OEM clamp. Leave bolts (11) loose for now.
6. Install accessory drive plate (4) with bolts (8) & (10). Secure bolts (10), snug bolts (8), tighten bolts (11) and (8).
7. Install accessory pump to plate (4) with bolts provided.
8. Install flat idler (7) with bushing (5) and bolt (10) at lower location the furthest from engine. Install grooved idler (6) with bushing (5) and bolt (10). Snap rings towards radiator.
9. Install belt (20) as shown in diagram, check for any belt interference.
10. Refill antifreeze, install negative battery cables, start and check belt tracking. Install inner fender.

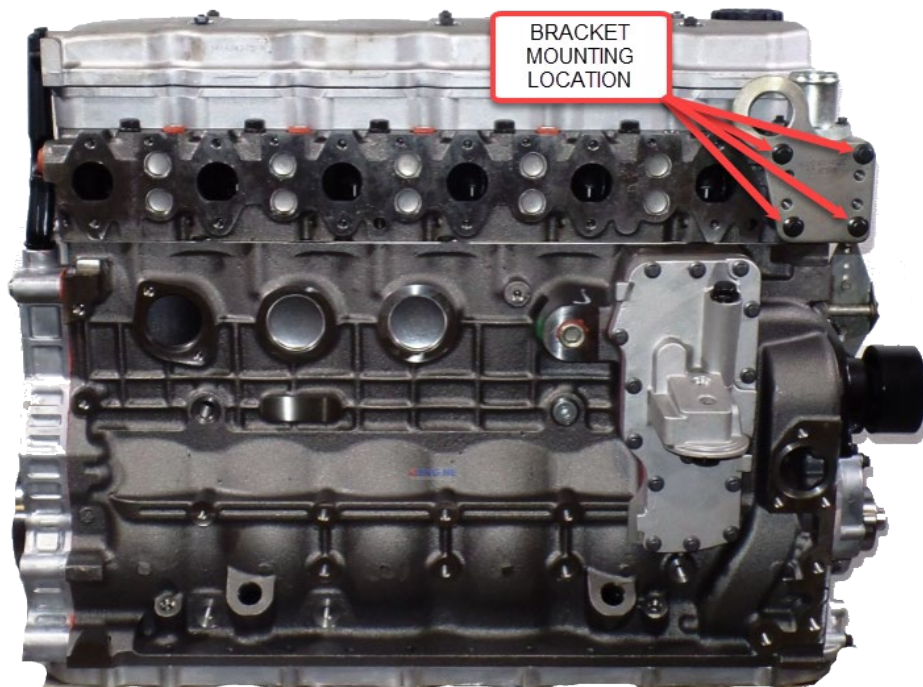

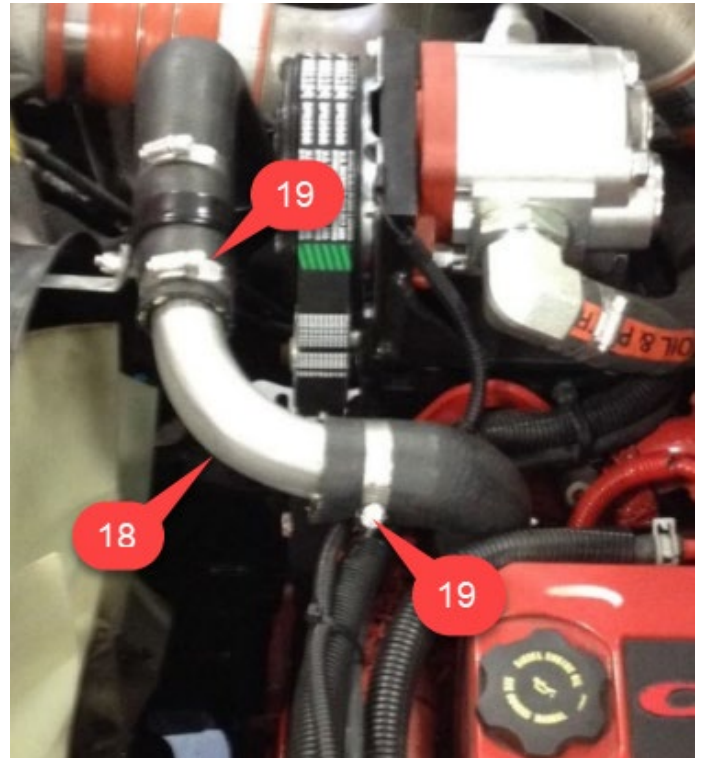
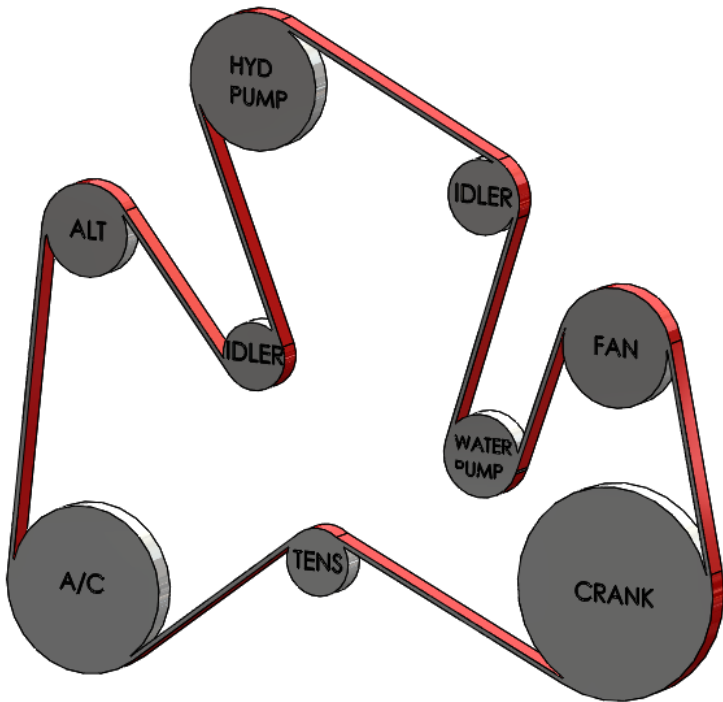

PARTS LIST

- | | |
|----------------------------|-----------------------------|
| 1. IMB601 (1) | 11. 10 x 110mm Flg Bolt (2) |
| 2. IMB602 (1) | 12. 3/8" Flat Washer (5) |
| 3. IMB603 (1) | 13. 10mm Lock Washer (2) |
| 4. IMP33A (1) | 14. 5081213 Belt (1) |
| 5. IMB605 (2) | 15. 3/8 x 1-1/2 Bolt (2) |
| 6. GPCD-8 (1) | 16. 3/8 Lock Washer (2) |
| 7. 89001 (1) | 17. 3/8 Nut (2) |
| 8. 10 x 20mm Flg Bolt (2) | 18. IMB33-01 Steel Tube (1) |
| 9. 10 x 40mm Flg Bolt (4) | 19. #28 Hose Clamp (3) |
| 10. 10 x 50mm Flg Bolt (6) | |

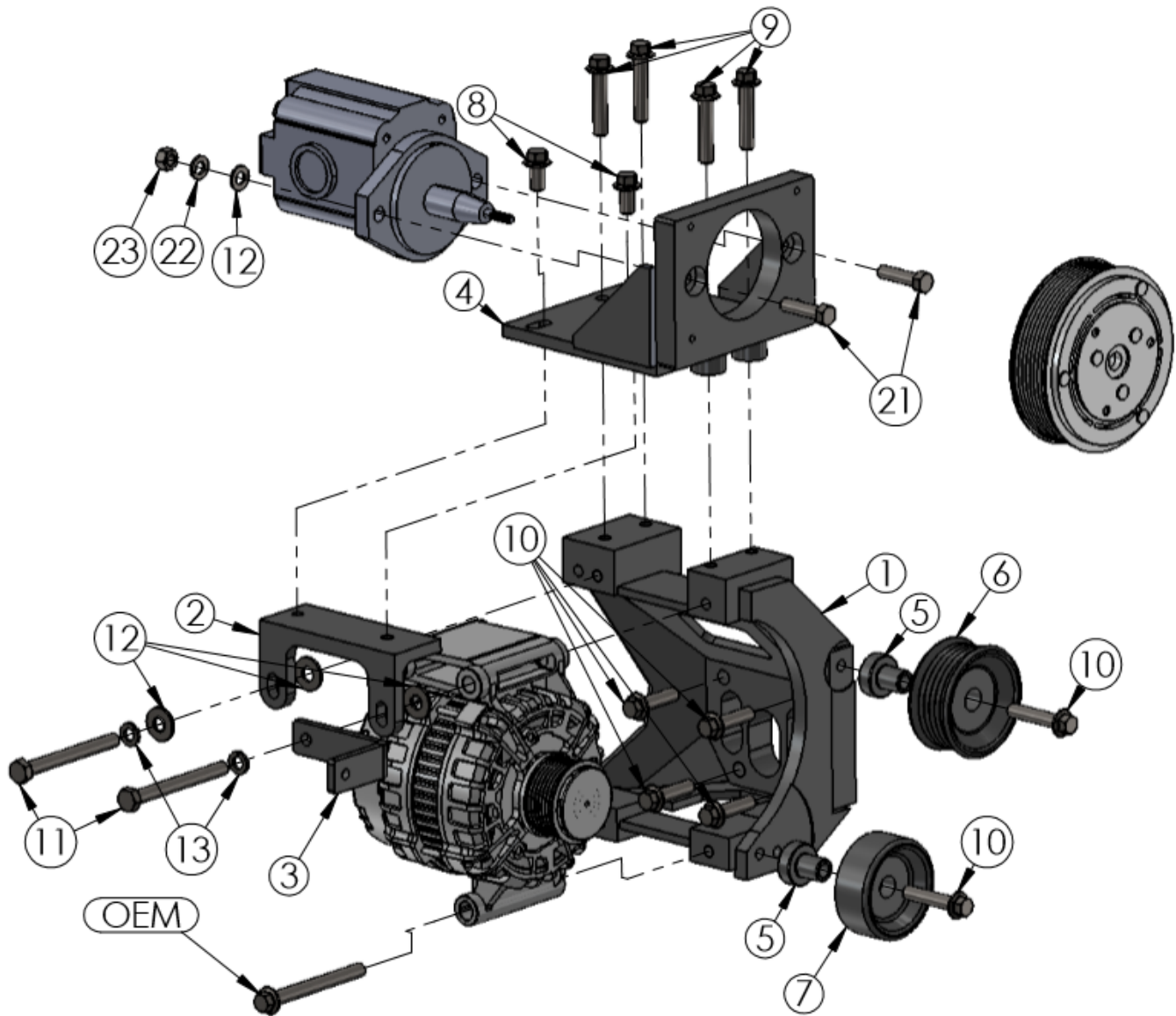

Disclaimer: (1.) Due to the custom nature and variation of all add-on systems of this type, no complete system kits are offered by the manufacturer, and any group of parts marketed as a kit is limited to only the individually defined parts in that specific kit. The system designer's rotating accessory components are not included, offered, or fully known by the manufacturer. In addition to the absence of the rotating accessory system, other potential components such as additional clamps, brackets, wear liners, hardware, or other items that may be required by the system designer must be identified and supplied by the actual system designer.

(2.) Due to vehicle manufacturer's assembly tolerances, production changes, and installation variances, it is the buyer's responsibility to insure adequate clearance for all components including space for and safe location of the fan, radiator, all lines, and wires. Check for possible movement, vibration, friction points, heat exposure and/or shifting of any and all components such as hoses, wires, and all other components including those that may otherwise be considered non-moving and/or unaffected by the installation (3.) The buyer is responsible for the entire installation of a mounting kit as the mounting kit is part of a custom process controlled by the buyer through their whole system design and directed installer as the installer evaluates, locates, routes, aligns, and tightens all components while determining if additional clamps, brackets, wear-liners, or other components may be required, beyond those included in the kit. Any additional items required, beyond those included in the kit, are to be provided at the expense of the buyer. (4.) The buyer is responsible for the development and communication of their whole system installation procedures, safety precautions, application, and use of the engine accessory mounting kit in their system, including efforts to maintain vehicle control and prevent pinch, wear, impact, and/or burn exposure on all hoses, wires, and other parts. (5.) The buyer is responsible for providing trained and experienced installation decision making with technical know-how to apply professional judgment that specifically applies to each individual installation. The buyers chosen installers must be qualified and experienced technicians that are familiar with the vehicle and accessory being mounted as well as the buyer's whole system design and installation procedures associated with the kit. (6.) The buyer is responsible for determining and achieving compliance to all regulatory issues that apply to the use of all products.

(7.) The manufacturer reserves the right to make changes and/or improvements to any product at any time with or without notice.