

INSTALLATION NOTES

1. Be sure to read and understand all available information including but not limited to instructions, warnings, sale terms, and warranties for the vehicle and all system components prior to attempting installation.
2. Remove negative cables and wires on batteries. Remove passenger side inner fender, remove fan belt.
3. Remove alternator, bracket, and lifting lug.
4. Install new alternator bracket (1) with bolts (9). Install OEM alternator and install angle bracket (3) that matches alternator bolt pattern with bolts (11) and washers (12) & (13). Use washers (12) between bracket (3) and alternator. Install wire harness support to keep harness off of alternator. Leave bolts (11) loose for now.
5. Install accessory drive plate (4) with bolts (8) & (10). Secure bolts (10), snug bolts (8), tighten bolts (11) adjust harness support to keep harness off of alternator and tighten bolts (8).
6. Install accessory hydraulic pump to plate (4) with bolts (21), washers (22), and plate (23) provided. Install flat idler (7) with bushing (5) and bolt (10) at lower location the furthest from engine. Install grooved idler (6) with bushing (5) and bolt (10). Snap rings towards radiator.
7. Secure wire harness to water line near fan pulley using clamps (14) & (15) and hardware (16) - (19). Pull slack from harness to keep it off of alternator. Keep clamps away from fan pulley. Push harness through OE clamp toward driver side to keep away from fan pulley if necessary.
8. Install belt (20) as shown in diagram, check for any belt interference.
9. Install negative battery cables, start and check belt tracking. Install inner fender.

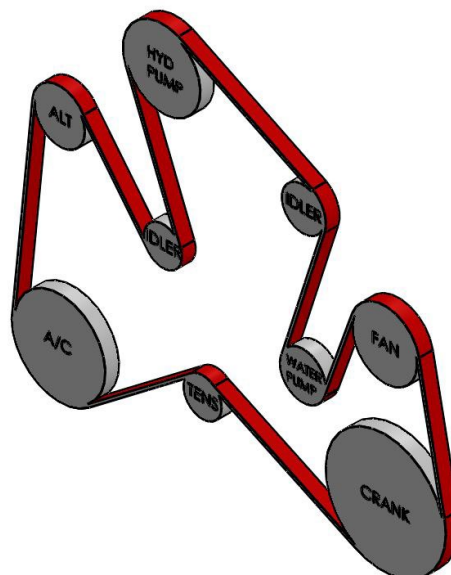

IMK60-I8

2016-2024

7000 Series 7300-7500 WORKSTAR 6.7 CUMMINS ISB

For use W-WO AC / Requires 8 Groove Clutch

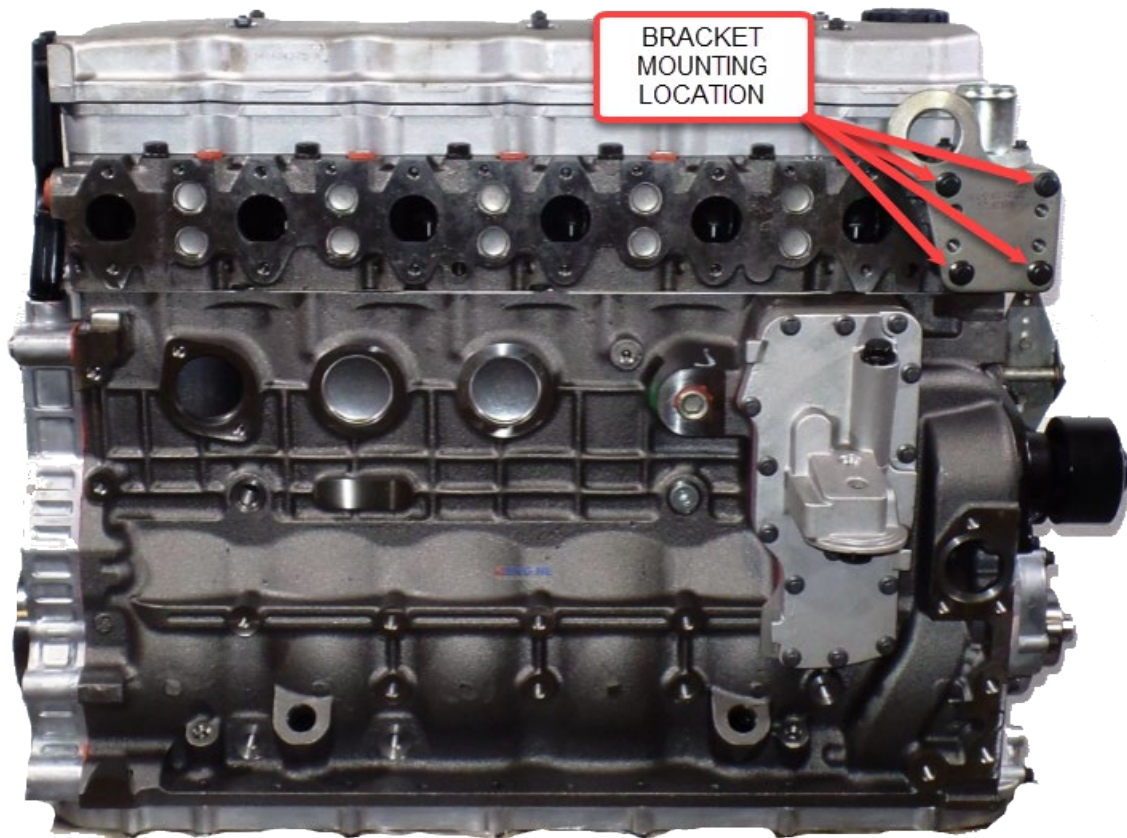

PARTS LIST

- | | |
|-----------------------------|-------------------------------|
| 1. IMB601 (1) | 13. 10mm Lock Washer (2) |
| 2. IMB602 (1) | 14. 16mm Clamp (1) |
| 3. IMB603 (1) | 15. 24mm Clamp (1) |
| 4. IMP60(0-4) (1) | 16. 1/4 x 1 Bolt (1) |
| 5. IMB605 (2) | 17. 1/4 Flat Washer (1) |
| 6. GPCD-8 (1) | 18. 1/4 Lock Washer (1) |
| 7. 89101 (1) | 19. 1/4 Nut (1) |
| 8. 10 x 20mm Flg Bolt (2) | 20. 5081333 Belt (1) |
| 9. 10 x 40mm Flg Bolt (4) | 21. 1/2" x 1 3/4" Bolt (2) |
| 10. 10 x 50mm Flg Bolt (5) | 22. 1/2" Lock Washer Bolt (2) |
| 11. 10 x 110mm Flg Bolt (2) | 23. #4 Pump Spacer (1) |
| 12. 3/8" Flat Washer (3) | |

IMK60-I8

2016-2024

7000 Series 7300-7500 WORKSTAR 6.7 CUMMINS ISB

For use W-WO AC / Requires 8 Groove Clutch

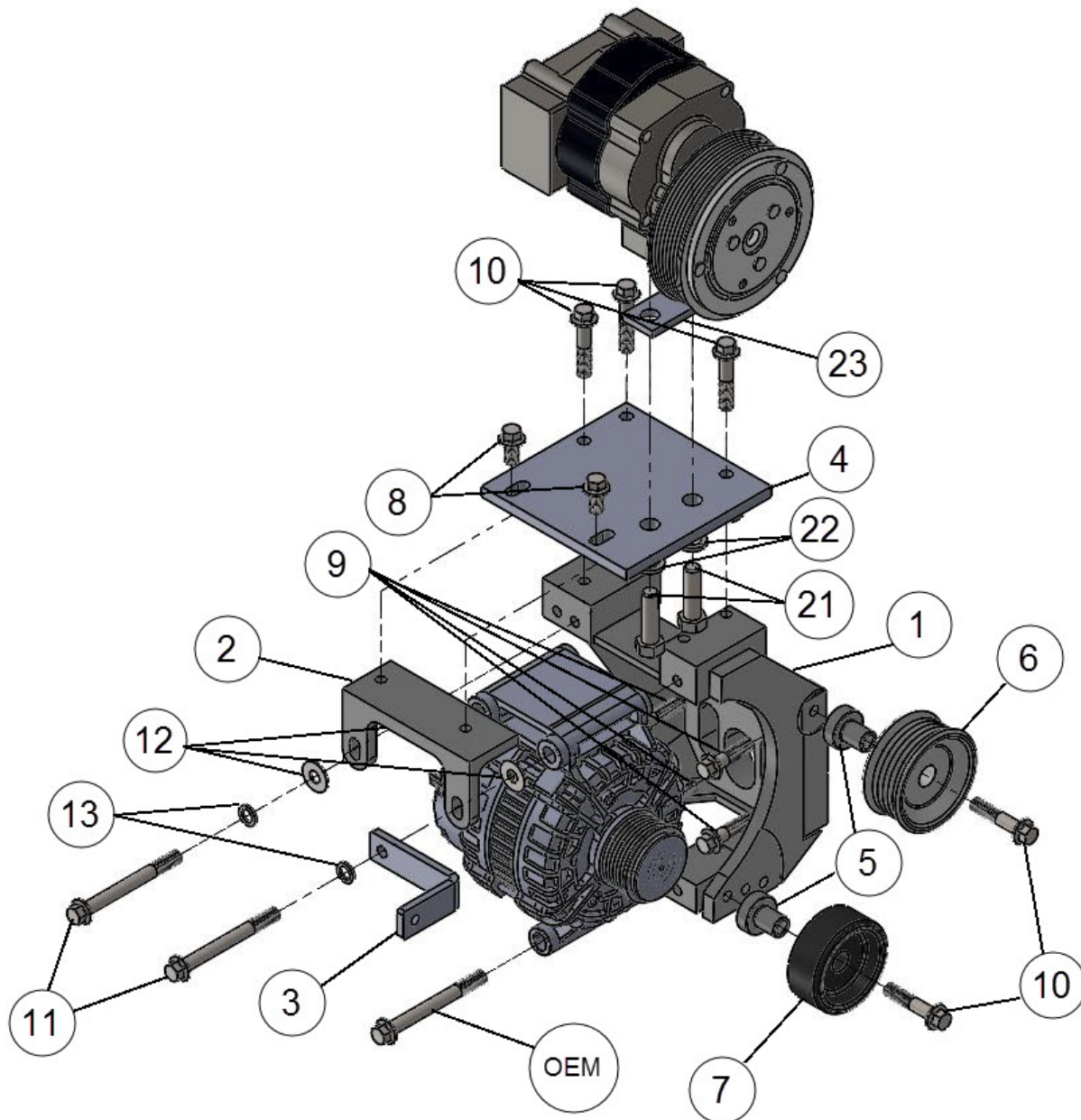

Disclaimer: Due to truck manufacturer's assembly tolerances, production changes, and installation variances, it is the buyer's responsibility to insure adequate clearance for all components including space for and safe location of the fan, radiator, all lines, and all wires. Check for possible movement, vibration, friction points, heat exposure and/or shifting of any and all components such as hoses, wires, and all other components including those that may otherwise be considered non-moving and/or unaffected by the installation. The buyer is to supply additional clamps, shields, brackets, wear-liners, hardware, etc., as needed for actual installation. (a) The buyer is responsible for the entire installation of a mounting kit as the mounting kit is a part of a custom process controlled by the buyer through their whole system design and their directed installer as the installer evaluates, locates, routes, aligns, and tightens all components while determining if additional clamps, brackets, wear liners, or other components may be required, beyond those included in the kit. Any additional items required, beyond those included in the kit, are to be provided at the expense of the buyer. (b) The buyer is responsible for the development and communication of their whole system installation procedures, safety precautions, application, and use of the engine accessory mounting kit in their system, including efforts to maintain vehicle control and prevent pinch, wear, impact, and/or burn exposure on all hoses, wires, and other parts. (c) The buyer is responsible for providing trained and experienced installation decision making with technical know-how to apply professional judgment that specifically applies to each individual installation. The buyer's chosen installers must be qualified and experienced technicians that are familiar with the vehicle and the accessory being mounted as well as the buyer's whole system design and installation procedures associated with the kit. Product configurations and design standards for all CW MILL EQUIPMENT CO., INC. products are subject to change without notice. Product variances may occur between similar past, present, & future units.