

## INSTALLATION NOTES

1. Be sure to read and understand all available information including but not limited to instructions, warnings, sale terms, and warranties for the vehicle and all system components prior to attempting installation.
2. Disconnect battery.
3. Drain coolant.
4. Remove air filter tube and filter box.
5. Modify the air filter box as shown for belt clearance. (figure 1)
6. Remove heater pipes and reinstall bolt to hold engine oil dipstick. (figure 2-3)
7. Remove crank bolt and install the included pulley and install new bolt-on items. (figure 5)
8. Remove alternator bolts and install main bracket. (figure 4) **(do not tighten)**
9. Install support bracket to main bracket tighten support bracket and then tighten main bracket.
10. Install tensioner (14) and belt (15). (figure 5)
11. Reinstall heater hoses and brackets. (figure 6-8)
12. Reinstall air filter tube and filter box.
13. Fill antifreeze.

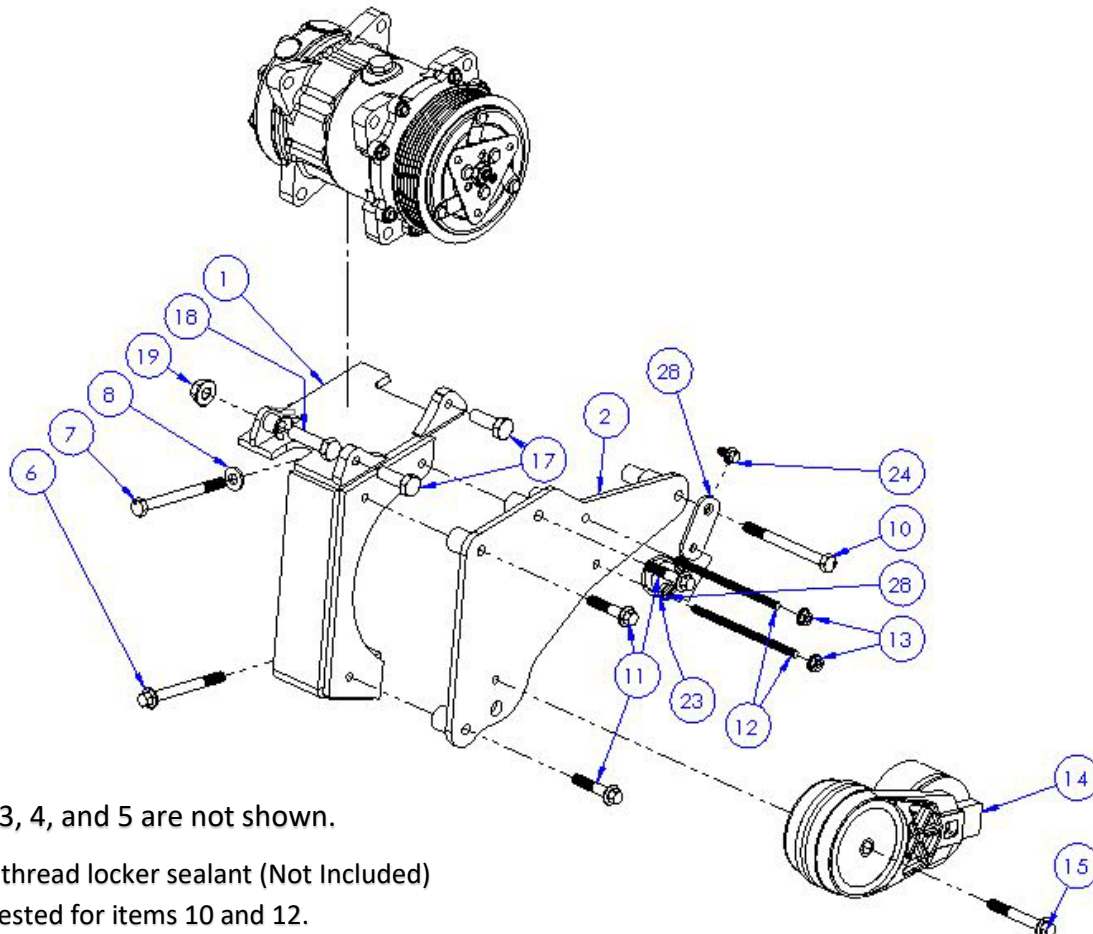

Items 3, 4, and 5 are not shown.

Use of thread locker sealant (Not Included)  
 is suggested for items 10 and 12.

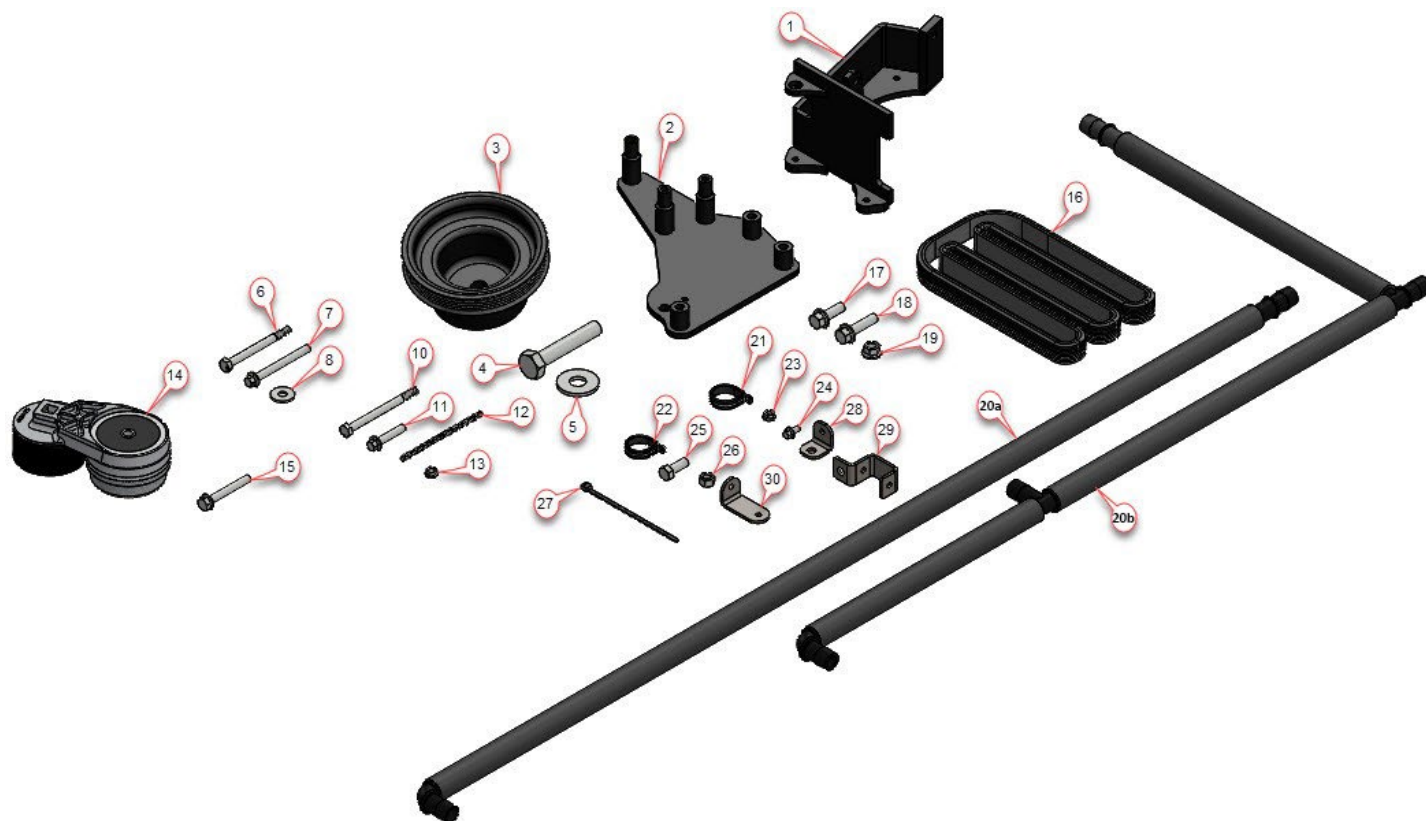

## PARTS LIST

- |                                   |  |
|-----------------------------------|--|
| 1. RMK30 (1)                      | 17. 10mm x 30mm Flange Bolts (2)       |
| 2. RMB30 (1)                      | 18. 10mm x 40mm Flange Bolt (1)        |
| 3. RPC306 3Pulley (1)             | 19. 10mm Flange Nut (1)                |
| 4. 16mm x 90mm Hex Bolt 1.5 (1)   | 20. a: R30HA-1                         |
| 5. 16mm Flat Washer (1)           | b: R30HA-2                             |
| 6. 8mm x 90mm Bolt (1)            | 21. #18 Heavy Duty Wire Loom Clamp (7) |
| 7. 8mm x 80mm Flange Bolt (1)     | 22. #16 Heavy Duty Wire Loom Clamp (3) |
| 8. 8mm Lock Washer (1)            | 23. 6mm Flange Nut (10)                |
| 9. OEM 8mm nut (1)                | 24. 6mm x 12mm Flange Bolt (9)         |
| 10. 8mm x 100mm Bolt (1)          | 25. 3/8" x 1" Bolt (4)                 |
| 11. 8mm x 40mm Flange Bolt (3)    | 26. 3/8" Nut (4)                       |
| 12. 6mm All Thread 115mm Long (2) | 27. Wire Tie Large (3)                 |
| 13. 6mm Flange Nuts (2)           | 28. 1" x 1" Hose Bracket (4)           |
| 14. 89364 Tensioner (1)           | 29. 1" x 1½" x 1" Hose Bracket (2)     |
| 15. 8mm x 60mm Flange Bolt (1)    | 30. 1" x 2" Hose Bracket (1)           |
| 16. 5060510                       |  |

FIGURE 1



FIGURE 3

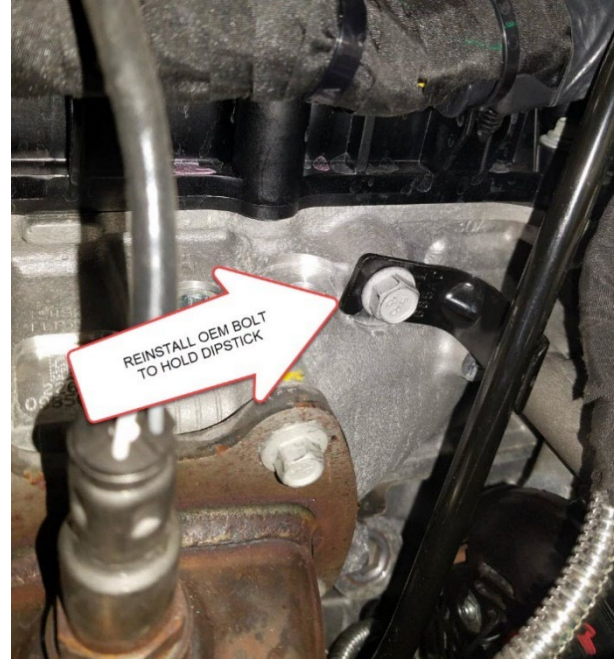

FIGURE 2





FIGURE 4

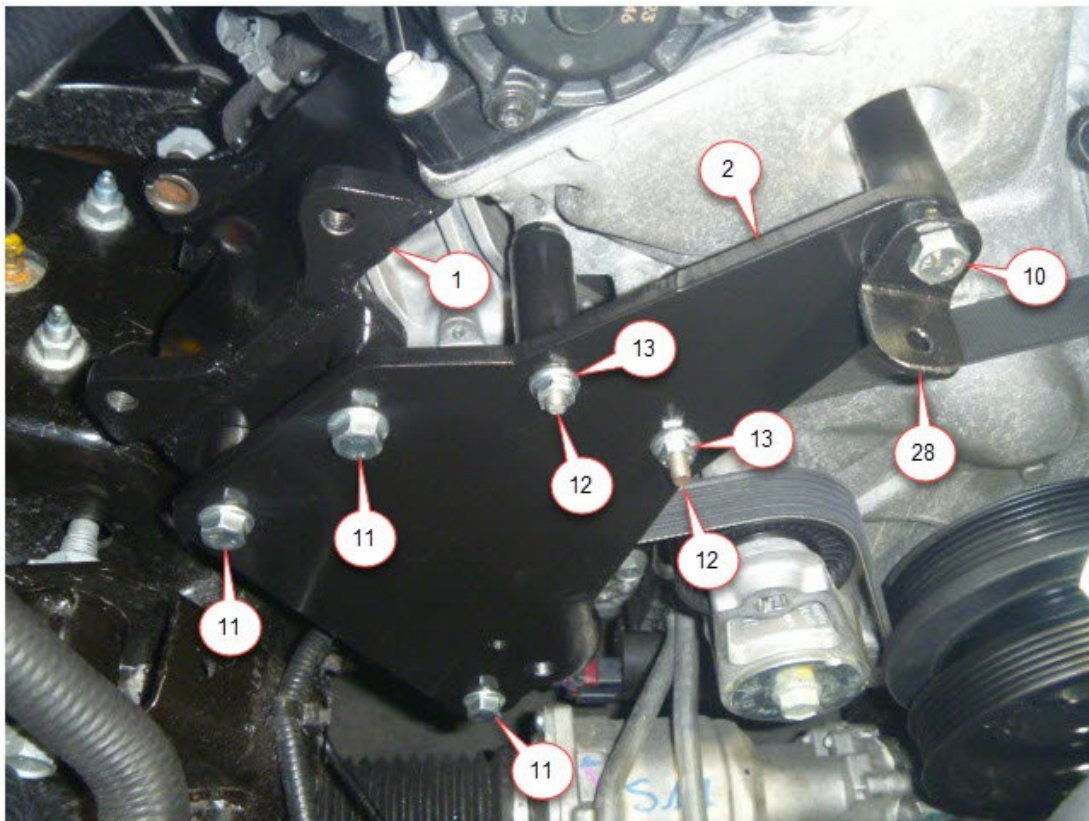

FIGURE 5

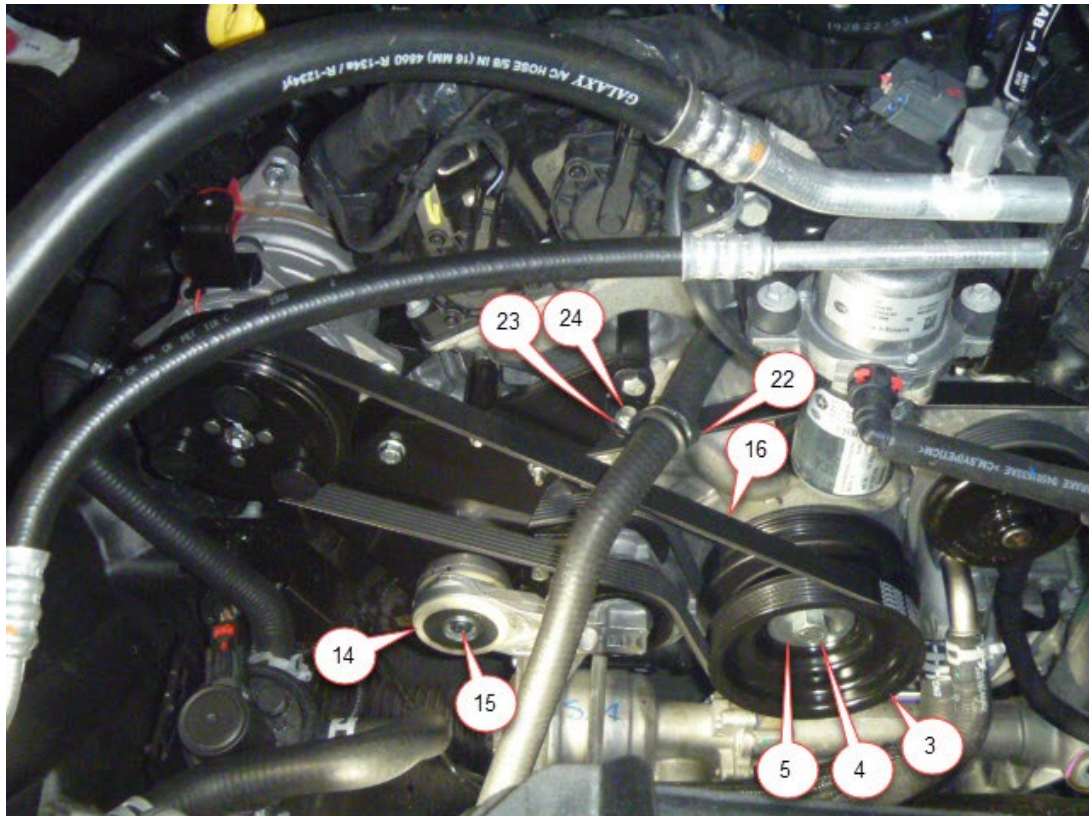



FIGURE 6

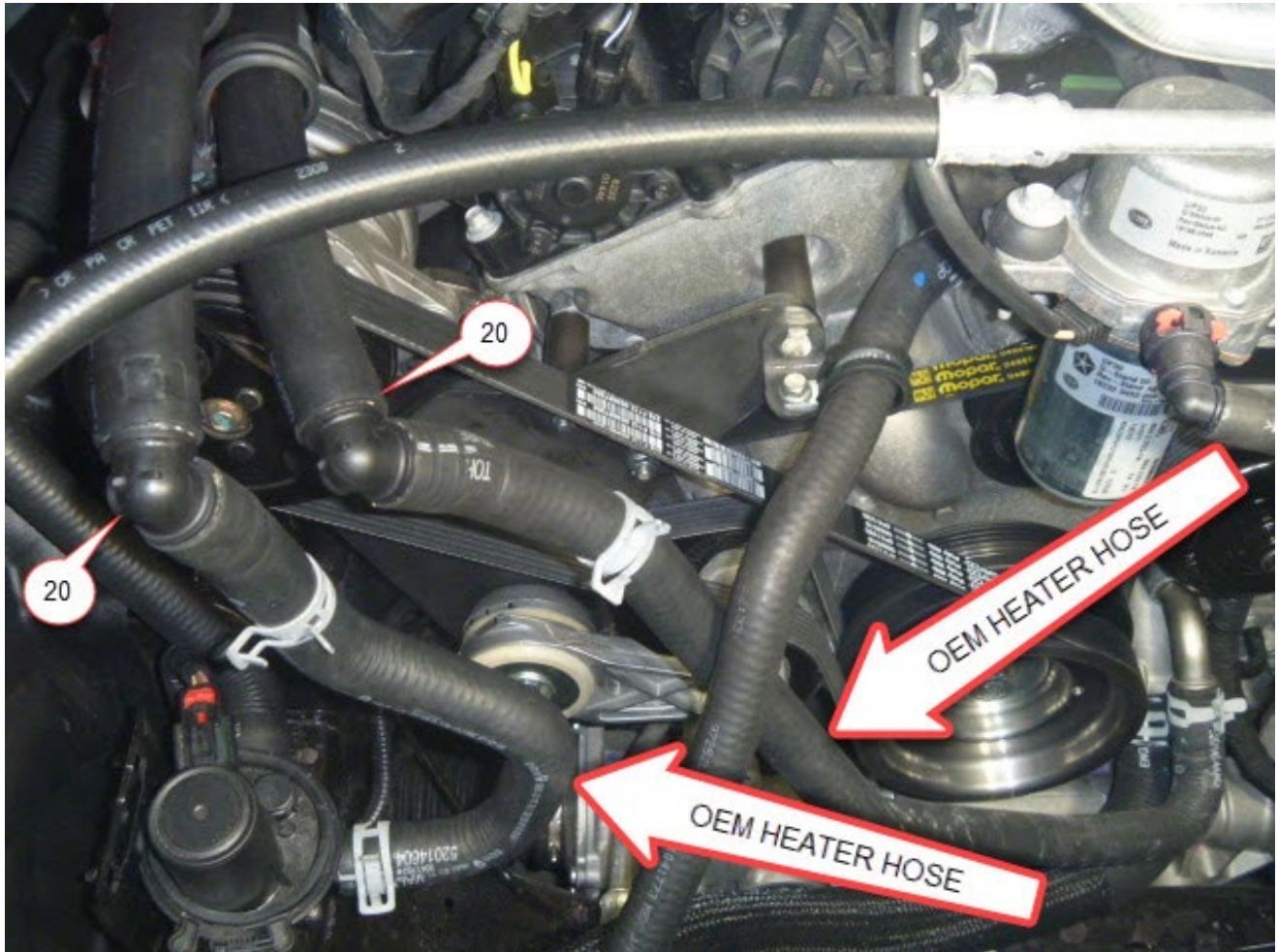

FIGURE 7

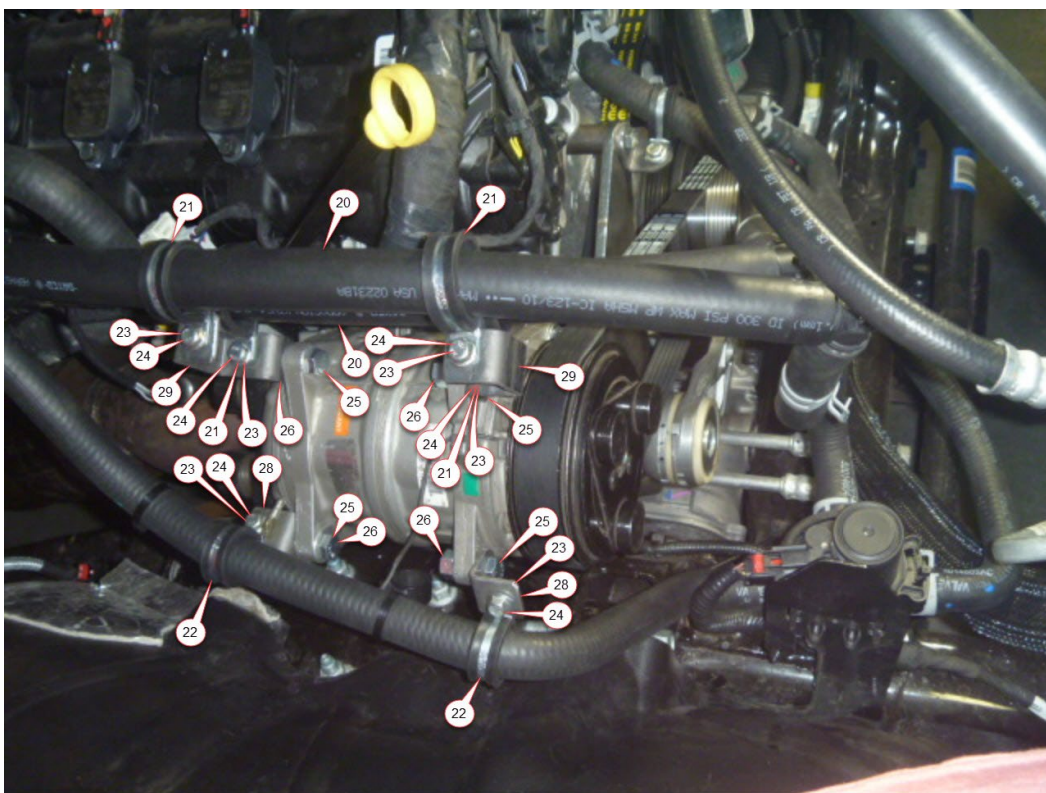



FIGURE 8



CW Mill Equipment Co., Inc. Mounting Kit and Mounting Kit Component Disclaimer: (1.) Due to the custom nature and variation of all add-on systems of this type, no complete system kits are offered by the manufacturer, and any group of parts marketed as a kit is limited to only the individually defined parts in that specific kit. The system designer's rotating accessory components are not included, offered, or fully known by the manufacturer. In addition to the absence of the rotating accessory system, other potential components such as additional clamps, brackets, wear liners, hardware, or other items that may be required by the system designer must be identified and supplied by the actual system designer. (2.) Due to vehicle manufacturer's assembly tolerances, production changes, and installation variances, it is the buyer's responsibility to ensure adequate clearance for all components including space for and safe location of the fan, radiator, all lines, and wires. Check for possible movement, vibration, friction points, heat exposure and/or shifting of any and all components such as hoses, wires, and all other components including those that may otherwise be considered non-moving and/or unaffected by the installation (3.) The buyer is responsible for the entire installation of a mounting kit as the mounting kit is part of a custom process controlled by the buyer through their whole system design and directed installer as the installer evaluates, locates, routes, aligns, and tightens all components while determining if additional clamps, brackets, wear-liners, or other components may be required, beyond those included in the kit. Any additional items required, beyond those included in the kit, are to be provided at the expense of the buyer. (4.) the buyer is responsible for the development and communication of their whole system installation procedures, safety precautions, application, and use of the engine accessory mounting kit in their system, including efforts to maintain vehicle control and prevent pinch, wear, impact, and/or burn exposure on all hoses, wires, and other parts. (5.) The buyer is responsible for providing trained and experienced installation decision making with technical know-how to apply professional judgment that specifically applies to each individual installation. The buyers chosen installers must be qualified and experienced technicians that are familiar with the vehicle and accessory being mounted as well as the buyer's whole system design and installation procedures associated with the kit. (6.) The buyer is responsible for determining and achieving compliance to all regulatory issues that apply to the use of all products. (7.) The manufacturer reserves the right to make changes and/or improvements to any product at any time with or without notice.