

INSTALLATION NOTES

Be sure to read and understand all available information including but not limited to instructions, warnings, sale terms, and warranties for the vehicle and all system components prior to attempting installation.

Disconnect the negative battery cable.

Remove the fan and fan shroud. (Fan nut has left hand threads.) The fan can be removed from underneath. Drain coolant below the level of the upper radiator hose and remove the upper hose to make it easier to remove the shroud. (Caution: Do not attempt to drain coolant while engine is hot!)

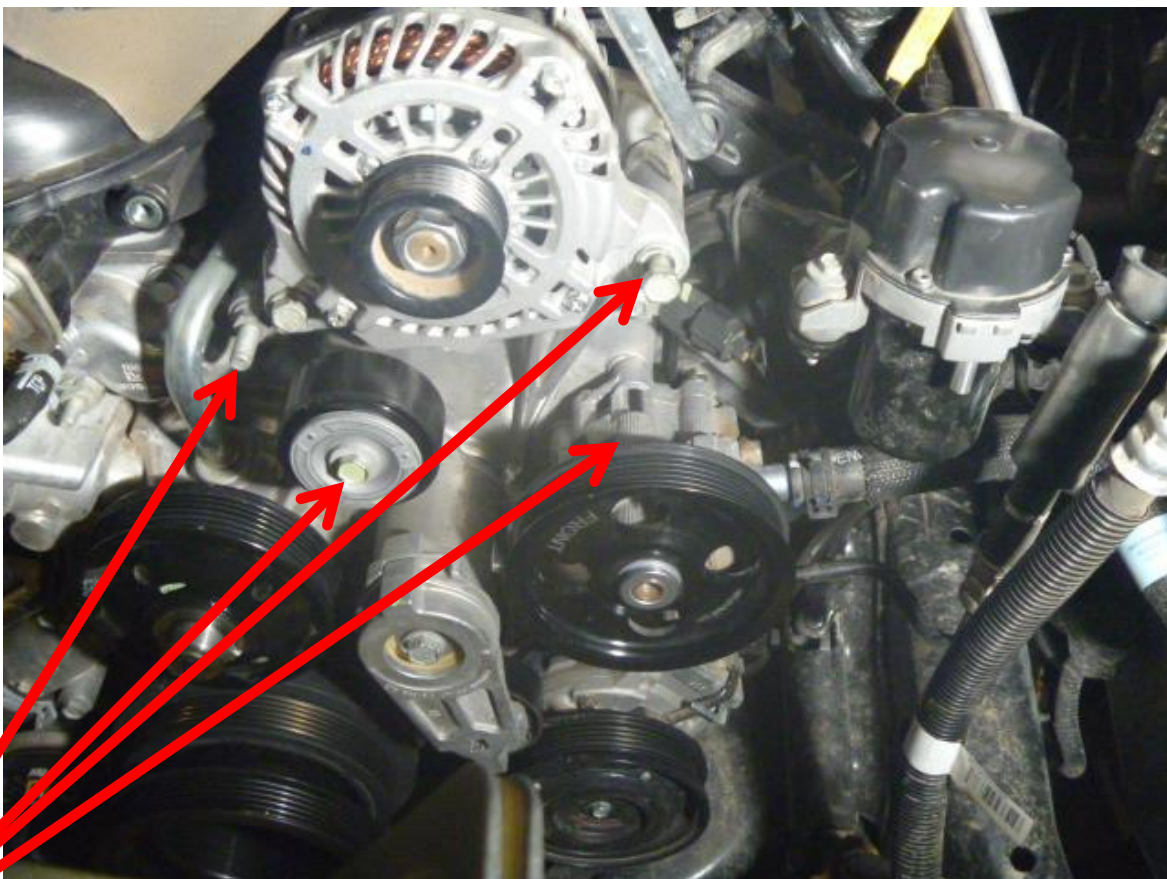

Remove the bolts from these locations. Remove the standoff for the air conditioner lines.

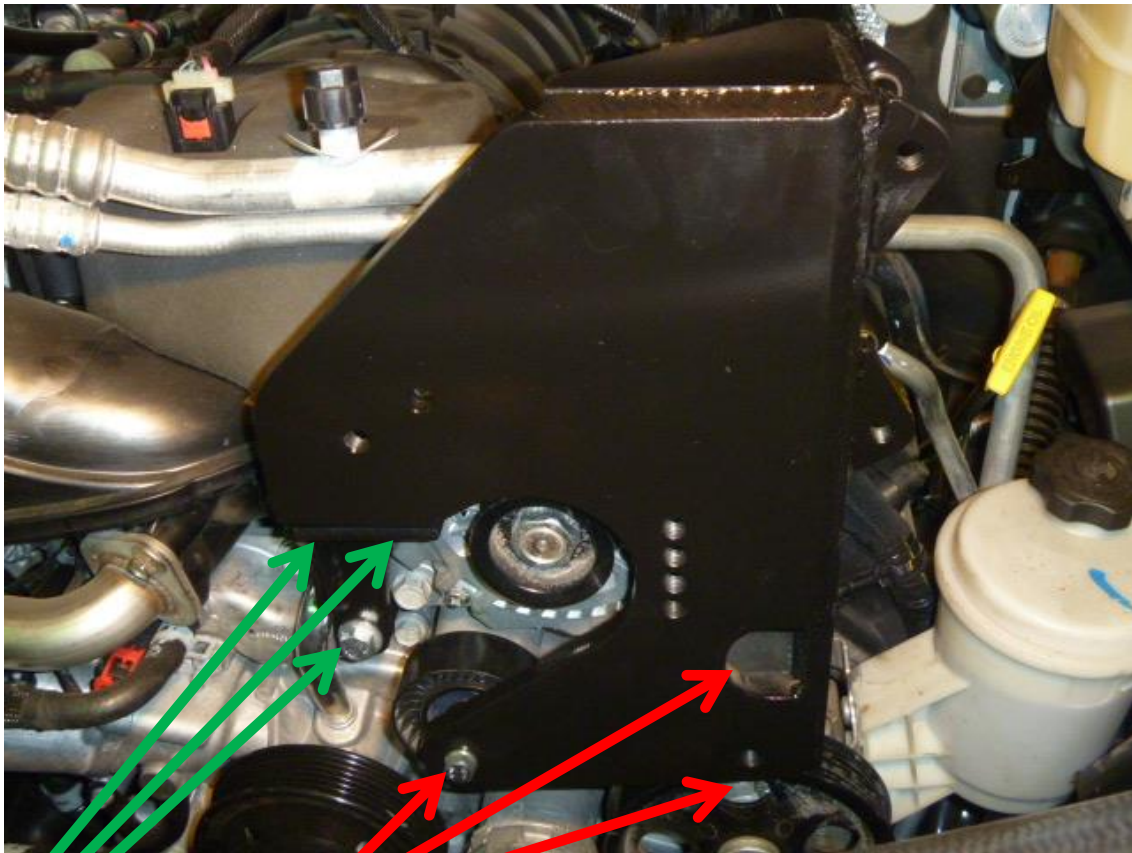

Install main bracket(5) using bolts(7,8,9) and lock washers(10,11). Tighten bolts securely.

Install the brace(6) using bolts(12,13).

Install the O.E.M. belt according to the O.E.M. belt routing.



Secure A/C line with the two #10 loom clamps(19) and two 6mm x 16mm flange bolts(20).

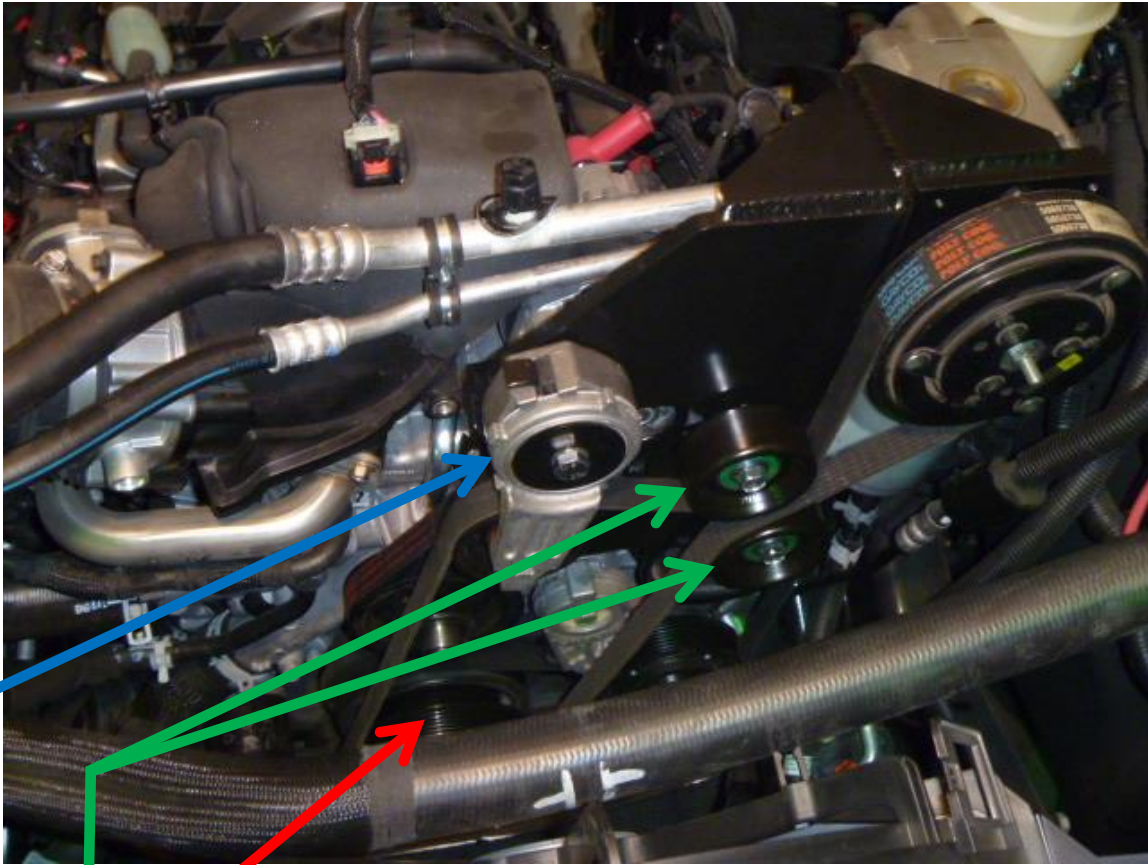

Remove harmonic balancer bolt. Install new drive pulley(1) using bolt(2) and flat washer(3). Before torquing the bolt, rotate the pulley counter clockwise until the drive studs make contact with the spokes in the balancer. Torque bolt(2) to 135 ft/lbs. Install the three 8mm set screws(26) into the drive pulley from the inside. Run them all out until they touch the damper evenly. Then, tighten each set a little at a time until you reach 15-20 inch pounds.

If not done already, install the clutch pump to bracket(5). Tighten pump bolts.

Install tensioner(17) using bolt(18).

Install idlers(15) as shown using idler spacers(14) and bolts(16). The upper idler will go into the lowest hole possible while the tensioner is fully compressed.

Install belt(25) as shown in photo above.

Install fan spacer(4) to water pump. Trim approximately 1" from the engine side top half of the fan shroud. Install upper portion of fan shroud and upper radiator hose. Replace the coolant. Install fan from underneath and then replace lower piece of the fan shroud. Reconnect negative battery cable. Make sure there are adequate clearances with all moving parts. Achieving the correct clearances and proper belt alignment is the installer's responsibility.

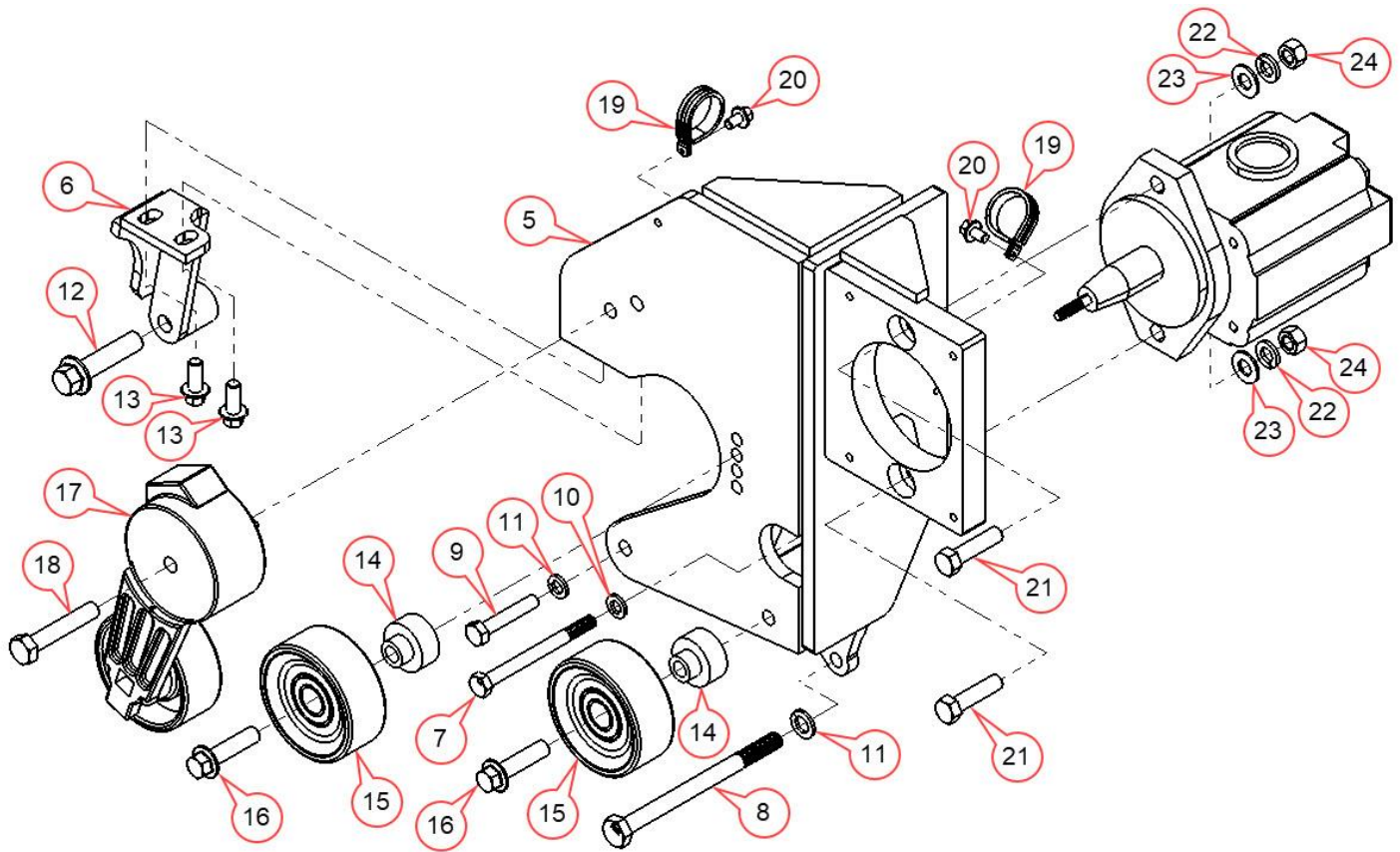

PARTS LIST

- | | |
|---------------------------------|---------------------------------|
| 1. DPC636 (1) | 14. FMB935 (2) |
| 2. 14mm x 120mm 1.5 (1) | 15. 89007 (2) |
| 3. 14mm Thick Flat Washer (1) | 16. 10mm x 40mm Flange Bolt (2) |
| 4. FSK38 (1) | 17. 89203-051 (1) |
| 5. RMP50A-6 (1) | 18. 10mm x 55mm (1) |
| 6. DMB631 (1) | 19. #10 Wire Loom Clamp (2) |
| 7. 10mm x 130mm (1) | 20. 6mm x 16mm Flange Bolt (2) |
| 8. 8mm x 90mm (1) | 21. 3/8" x 1-1/2" Bolt (2) |
| 9. 8mm x 45mm (1) | 22. 3/8" Lock Washer (2) |
| 10. 10mm Lock Washer (1) | 23. 3/8" Flat Washer (2) |
| 11. 8mm Lock Washer (2) | 24. 3/8" Nut (1) |
| 12. 10mm x 50mm Flange Bolt (1) | 25. 5060730 Belt (1) |
| 13. 8mm x 20mm Flange Bolt (2) | 26. 8mm x 20mm Set Screws (3) |

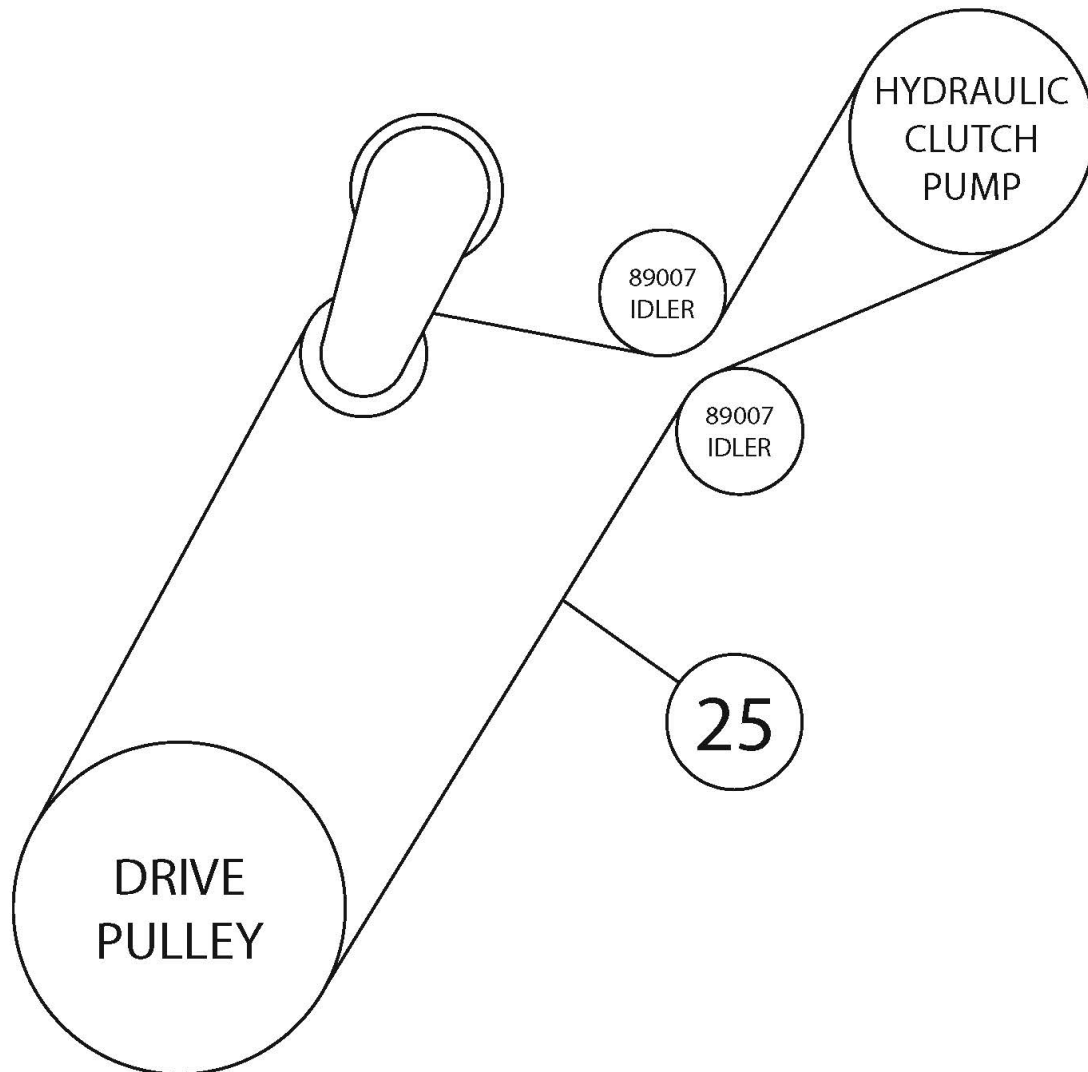

Disclaimer: (1.) Due to the custom nature and variation of all add-on systems of this type, no complete system kits are offered by the manufacturer, and any group of parts marketed as a kit is limited to only the individually defined parts in that specific kit. The system designer's rotating accessory components are not included, offered, or fully known by the manufacturer. In addition to the absence of the rotating accessory system, other potential components such as additional clamps, brackets, wear liners, hardware, or other items that may be required by the system designer must be identified and supplied by the actual system designer. (2.) Due to vehicle manufacturer's assembly tolerances, production changes, and installation variances, it is the buyer's responsibility to ensure adequate clearance for all components including space for and safe location of the fan, radiator, all lines, and wires. Check for possible movement, vibration, friction points, heat exposure and/or shifting of any and all components such as hoses, wires, and all other components including those that may otherwise be considered non-moving and/or unaffected by the installation (3.) The buyer is responsible for the entire installation of a mounting kit as the mounting kit as the mounting kit is part of a custom process controlled by the buyer through their whole system design and directed installer as the installer evaluates, locates, routes, aligns, and tightens all components while determining if additional clamps, brackets, wear-liners, or other components may be required, beyond those included in the kit. Any additional items required, beyond those included in the kit, are to be provided at the expense of the buyer. (4.) The buyer is responsible for the development and communication of their whole system installation procedures, safety precautions, application, and use of the engine accessory mounting kit in their system, including efforts to maintain vehicle control and prevent pinch, wear, impact, and/or burn exposure on all hoses, wires, and other parts. (5.) The buyer is responsible for providing trained and experienced installation decision making with technical know-how to apply professional judgment that specifically applies to each individual installation. The buyers chosen installers must be qualified and experienced technicians that are familiar with the vehicle and accessory being mounted as well as the buyer's whole system design and installation procedures associated with the kit. (6.) The buyer is responsible for determining and achieving compliance to all regulatory issues that apply to the use of all products. (7.) The manufacturer reserves the right to make changes and/or improvements to any product at any time with or without notice.