

INSTALLATION NOTES

1. Disconnect the negative battery cables. Remove the four nuts holding the fan shroud to the engine brackets. Remove the driver side fan shroud bracket from the engine, it will not be reused. Unplug the fan wire. Using the appropriate tool loosen the fan nut (Fan nut has right hand threads). Then remove the fan and fan shroud from the engine compartment. Remove the engine belt.
2. Remove the driver side inner fender. Disconnect the 5/16" P/S hose at the T. Then route it to the outside of the charge air tube and reconnect. When doing this, if the cap is left on the P/S reservoir, the fluid will only leak a small amount. Push tabs in on the fuse box housing and lift the fuse box up to allow access to the bottom of the housing. Secure the hose to the bottom of the fuse box housing with the wire loom clamp (19), bolt (17), and nut (18) from under the fender as shown in the picture. If installing on a 4500 or 5500 chassis, the power steering hose mounted to the steering gear box will need to be moved. To do this, remove the nut and clamp from power steering hose on the steering gear box. Install relocating bracket (15) using O.E.M. nut and install the power steering hose to bracket (15) using the O.E.M. clamp and bolt (16) as shown in the second photo.
3. Using three 8mm x 50mm flange bolts (4) with nuts (5) and one 8mm x 25mm flange bolt (8), install the bracket (1) onto the engine. Remove the bolt holding the upper radiator hose to the engine. Install brace (2) onto the engine with two 10mm x 20mm flange bolts (6) and onto the bracket with two 8mm x 20mm flange bolts (7). Secure bolts properly. Install the auxiliary alternator onto bracket (1) using bolts (13). Cut one inch from the back of the radiator hose brace and install it to the engine using the front bolt (6) of the bracket brace (2). Replace the inner fender with OEM hardware.
4. Install the idler (10) onto the bracket (1) using bolt (12), flat washer (11), and spacer (9) installing it into the lowest hole possible making it allowable to install the belt without excessive force. Install the belt (22) according to belt diagram. Using the clamp (21), bolt (20), and nut (5) provided, secure the small upper radiator hose to the side of the fuse box housing as shown in the third picture. Replace the fuse box. Replace the fan and fan shroud with OEM hardware. Install the fan shroud brace (3) onto the bracket with bolt (7) and to the fan shroud using bolt (8) and the OEM nut. Reconnect the battery cables. Run vehicle and check for proper belt tracking.

NOTE: Make certain any hoses, wires or components that were relocated during the installation are securely fastened and do not come in contact with any hot or moving parts.

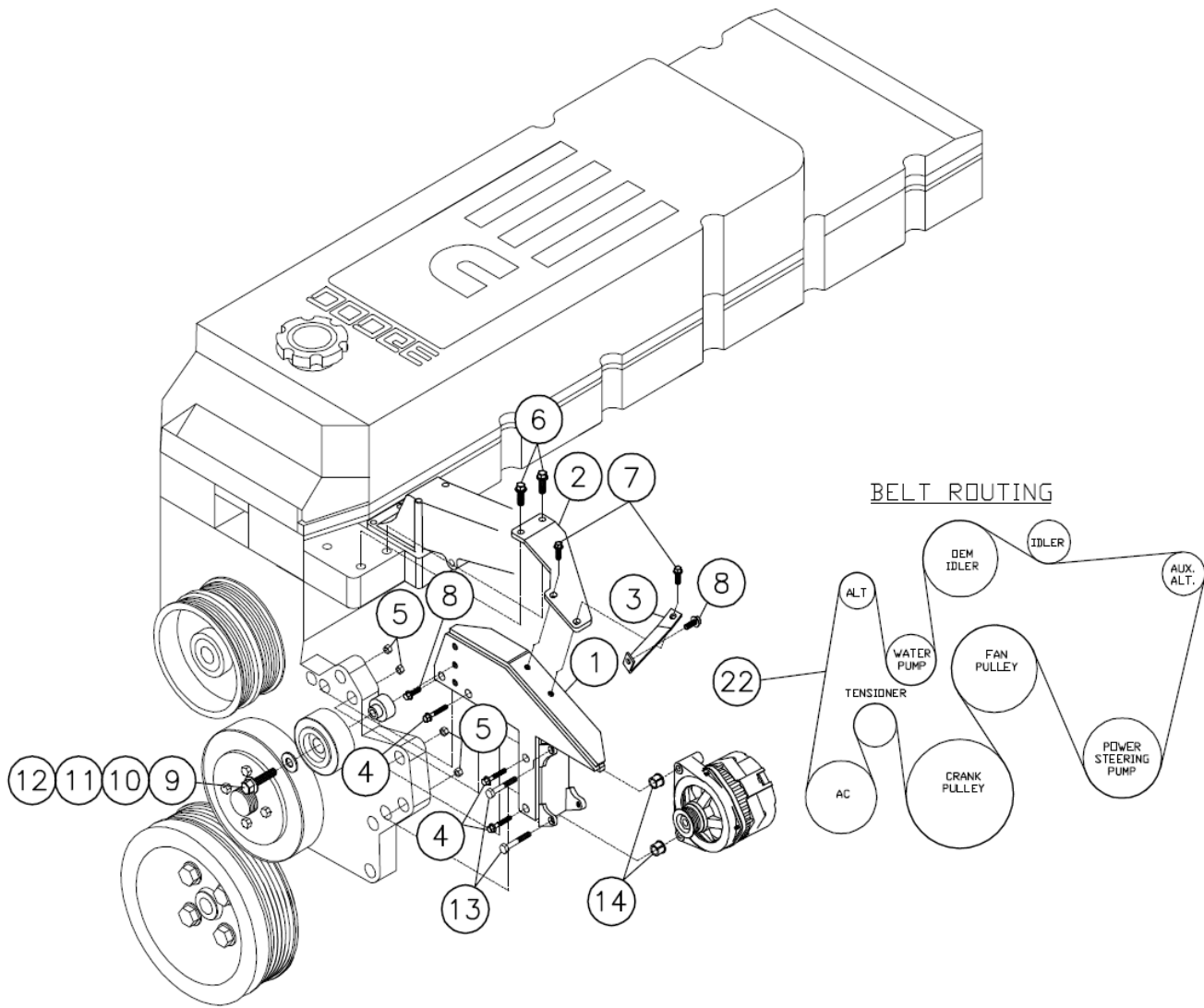

PARTS LIST

- 1. RMP6092V (1)
- 2. DMB591 (1)
- 3. DMB592 (1)
- 4. 8mm x 50mm Flange (3)
- 5. 8mm Flange Nut (4)
- 6. 10mm x 20mm Flange (2)
- 7. 8mm x 20mm Flange (2)
- 8. 8mm x 25mm Flange (2)
- 9. DMB594 (1)
- 10. 89048 Idler (1)
- 11. 3/8 Flat Washer (1)
- 12. 10mm x 45mm (1)
- 13. 10mm x 80mm Flange (2)

- 14. 1255-0090 Slide Bushing (2)

POWER STEERING LINE SUPPORT

- 15. DMB593 (1)
- 16. 6mm x 12mm Flange (1)

HOSE SUPPORT KIT

- 17. 6mm x 16mm Flange
- 18. 6mm Flange Nut (1)
- 19. #16 Wire Loom Clamp (1)
- 20. 8mm x 20mm Short Head Flange (1)
- 21. #32 Wire Loom Clamp (1)
- 22. 5081305 Belt (1)





11/6/2023