



RMK60A-I8

2019-2024 RAM 2500-5500

6.7L I6 Cummins Diesel w/ A/C, w/o Dual Alternators

Requires SAE Two Bolt 'A' Flange Pump, 8-Groove Clutch
Recommended 1.75 in³ or 8 gal. Pump w/ 12hp Restriction
Using a Rear Ported Pump Would Be Best

NOTE: Will NOT Work w/ 6" O.D. Clutch

NOTE: Will NOT Work w/ Trucks Equipped w/ Lane Departure

INSTALLATION NOTES

1. The buyer is responsible for providing trained and experienced installation decision making with technical know-how to apply professional judgment that specifically applies to each individual installation.
2. Be sure to read and understand all available information including but not limited to instructions, warnings, sale terms, and warranties for the vehicle and all system components prior to attempting installation.
3. Disconnect the negative battery cables.
4. Remove the top half of the fan shroud. Remove the four nuts holding the fan ring to the engine. Unplug the fan wire. Using the appropriate tool loosen the fan nut (Fan nut has right-hand threads). Then, remove the fan and fan ring from the engine compartment.
5. Remove the OEM belt.
6. Remove the power steering pump. Then, remove the upper driver side fan ring brace from the engine. The brace will not be reused.
7. Install the pump assemblies according to manufacturers' specifications onto the main bracket (1) with clutch pump mounting hardware (15-18). Do not install the clutch at this time. Install the main bracket (1) and clutch pump assembly onto the engine with mounting hardware (2-4). Do not tighten completely. Install the main bracket support brace (5) onto the main bracket (1) and the engine with mounting hardware (6-7) and bolt (9). Tighten all bolts very lightly. Then, tighten bracket and brace bolts securely. Install clutch assembly.
8. Reinstall power steering pump with OEM hardware. Install the smooth idler pulley assembly (11-14) onto the main bracket (1) in the lowest hole possible for now. Install belt (21) according to belt diagram. If the belt is too short. Move the smooth idler pulley assembly (11-14) up a hole until the belt can be installed.
9. Replace the fan and fan shroud with OEM hardware. Install the fan shroud support brace (8) onto the main bracket (1) with bolt (9) and to the fan ring using bolt (10) and the OEM nuts. Replace the top half of the fan shroud with OEM hardware.
10. If there is not adequate clearance between the pump bracket and power steering hose. Install clearance bracket (19) with bolt (20) as shown in the photo.
11. Reconnect the battery cables.

CAUTION: Before starting the engine. Check to make certain no wires, hoses, etc. that may have been disturbed during installation do not come in contact with any hot or moving parts. Run the engine and check for proper belt tracking, adjust if necessary.

Requires SAE Two Bolt 'A' Flange Pump, 8-Groove Clutch Recommended 1.75 in³ or 8 gal. Pump w/ 12hp Restriction

Using a Rear Ported Pump Would Be Best

NOTE: Will NOT Work w/ 6" O.D. Clutch

NOTE: Will NOT Work w/ Trucks Equipped w/ Lane Departure

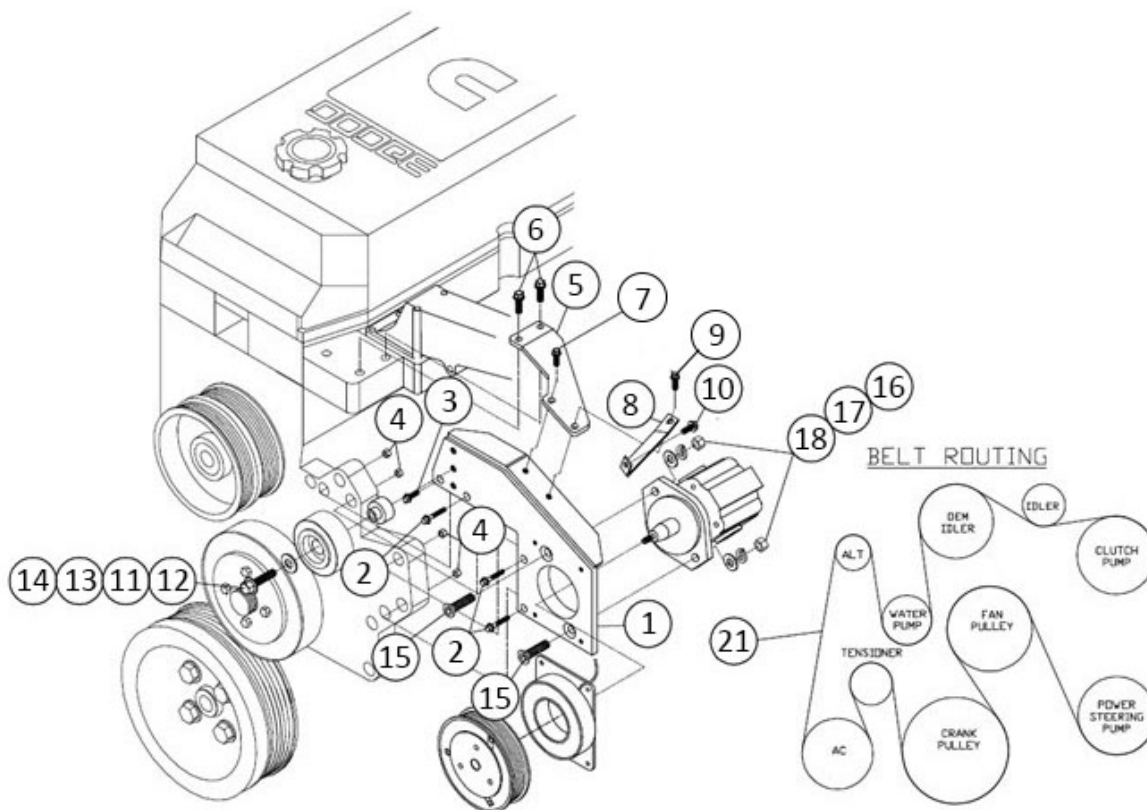

PARTS LIST							
Item	Part Number	Description	Qty.	Item	Part Number	Description	Qty.
Main Bracket				Smooth Idler Pulley Assembly			
1	RMP60A	Main Bracket	1	11	89048	Dayco Smooth Idler Pulley	1
Main Bracket Mounting Hardware				12	DMB594	Machined Idler Bushing	1
2	1013316	M8-1.25 x 50mm Flange Bolt	3	13	1007644	3/8" Flat Washer	1
3	1011887	M8-1.25 x 25mm Flange Bolt	1	14	1006630	M10-1.5 x 45mm Bolt	1
4	1013333	M8-1.25 Flange Nut	4	Clutch Pump Mounting Hardware			
Main Bracket Support Brace				15	1003930	3/8"-16 x 1-3/4" NC FHSCS	2
5	DMB591	Main Bracket Support Brace	1	16	1010314	3/8"-16 NC Nut	2
Main Bracket Support Brace Mounting Hardware				17	1010315	3/8" Lock Washer	2
6	1008390	M10-1.5 x 20mm Flange Bolt	2	18	1011654	5/16" Flat Washer	2
7	1013329	M8-1.25 x 20mm Flange Bolt	1	Power Steering Hose Clearance Hardware			
Fan Shroud Support Brace				19	RMB601	P/S Hose Clearance Bracket	1
8	DMB592	Fan Shroud Support Brace	1	20	1016342	M6-1.0 x 30mm Flange Bolt	1
Fan Shroud Support Brace Mounting Hardware				Belt			
9	1013329	M8-1.25 x 20mm Flange Bolt	1	21	5081305	Dayco 8-Groove 130.5" Belt	1
10	1011887	M8-1.25 x 25mm Flange Bolt	1				

CW **CW Mill Equipment Co., Inc.**
 14 Commerce Drive Sabetha, KS 66534
 Phone: (785) 284-3454
 Fax: (785) 284-3601
 Email: brackets@cwmill.com
 Website: www.cwkits.com

MOUNTING KITS

RMK60A-I8

2019-2024 RAM 2500-5500

6.7L I6 Cummins Diesel w/ A/C, w/o Dual Alternators

Requires SAE Two Bolt 'A' Flange Pump, 8-Groove Clutch
 Recommended 1.75 in³ or 8 gal. Pump w/ 12hp Restriction
 Using a Rear Ported Pump Would Be Best

NOTE: Will NOT Work w/ 6" O.D. Clutch

NOTE: Will NOT Work w/ Trucks Equipped w/ Lane Departure



Power Steering Hose Clearance Hardware (19-20)

Disclaimer: (1.) Due to the custom nature and variation of all add-on systems of this type, no complete system kits are offered by the manufacturer, and any group of parts marketed as a kit is limited to only the individually defined parts in that specific kit. The system designer's rotating accessory components are not included, offered, or fully known by the manufacturer. In addition to the absence of the rotating accessory system, other potential components such as additional clamps, brackets, wear liners, hardware, or other items that may be required by the system designer must be identified and supplied by the actual system designer. (2.) Due to vehicle manufacturer's assembly tolerances, production changes, and installation variances, it is the buyer's responsibility to ensure adequate clearance for all components including space for and safe location of the fan, radiator, all lines, and wires. Check for possible movement, vibration, friction points, heat exposure and/or shifting of any and all components such as hoses, wires, and all other components including those that may otherwise be considered non-moving and/or unaffected by the installation (3.) The buyer is responsible for the entire installation of a mounting kit as the mounting kit as the mounting kit is part of a custom process controlled by the buyer through their whole system design and directed installer as the installer evaluates, locates, routes, aligns, and tightens all components while determining if additional clamps, brackets, wear-liners, or other components may be required, beyond those included in the kit. Any additional items required, beyond those included in the kit, are to be provided at the expense of the buyer. (4.) The buyer is responsible for the development and communication of their whole system installation procedures, safety precautions, application, and use of the engine accessory mounting kit in their system, including efforts to maintain vehicle control and prevent pinch, wear, impact, and/or burn exposure on all hoses, wires, and other parts. (5.) The buyer is responsible for providing trained and experienced installation decision making with technical know-how to apply professional judgment that specifically applies to each individual installation. The buyers chosen installers must be qualified and experienced technicians that are familiar with the vehicle and accessory being mounted as well as the buyer's whole system design and installation procedures associated with the kit. (6.) The buyer is responsible for determining and achieving compliance to all regulatory issues that apply to the use of all products. (7.) The manufacturer reserves the right to make changes and/or improvements to any product at any time with or without notice