



CW Mill Equipment Co., Inc.

14 Commerce Drive Sabetha, KS 66534

Phone: (785) 284-3454

Fax: (785) 284-3601

Email: brackets@cwmill.com

Website: www.cwkits.com

VFK241A-I6

2021-2024 Ford E-350-E-450 Cutaway Van
7.3L V8 Gas w/ A/C, w/o OEM Dual Alternators

Requires 6-Groove Clutch
Requires SAE Two-Bolt 'A' Flange Pump
Recommend a 1.75 in.³ or 8 gal. Pump w/ 12hp Restriction

INSTALLATION NOTES

1. The buyer is responsible for providing trained and experienced installation decision making with technical know-how to apply professional judgment that specifically applies to each individual installation.
2. Be sure to read and understand all available information including but not limited to instructions, warnings, sales terms, and warranties for the vehicle and all system components prior to attempting installation.
3. Disconnect negative battery cable. Drain radiator for top hose removal.
4. Remove air cleaner box assembly. Cut box as shown. Remove upper radiator hose. Remove fan shroud. Remove fan clutch wire and bracket from engine. Remove belt. Disconnect alternator wires and remove alternator. Remove OEM alternator bracket and bolts.
5. Install new bracket (1) with 10mm x 150mm bolts (3) and 10mm lock washers (4). (Make sure to install bolt into bracket hole closest to water pump before installing bracket)
6. Install wire extension and heat shrink to alternator wire. Install alternator with OEM 10mm x 90mm bolt (8) and 10mm x 30mm flange bolt (9). Wires will go behind the bracket.
7. Install idler pulleys (5) with machined bushings (6) and 10mm x 40mm flange bolts (7). Install clutch pump with 10mm x 30mm flange bolts (10) and 10mm flange nuts (11). Install belt (16). Install fan wire and bracket.
8. Install new radiator hose and pipe (17-25). Install fan shroud. Install air cleaner bracket (2) as shown. Install air cleaner assembly. Fill coolant.

NOTE: Check for any water leaks and any hoses or wires that were disturbed during installation do not come in contact with any hot or moving parts. Run engine and check for proper belt tracking.

Disclaimer: (1.) Due to the custom nature and variation of all add-on systems of this type, no complete system kits are offered by the manufacturer, and any group of parts marketed as a kit is limited to only the individually defined parts in that specific kit. The system designer's rotating accessory components are not included, offered, or fully known by the manufacturer. In addition to the absence of the rotating accessory system, other potential components such as additional clamps, brackets, wear liners, hardware, or other items that may be required by the system designer must be identified and supplied by the actual system designer. (2.) Due to vehicle manufacturer's assembly tolerances, production changes, and installation variances, it is the buyer's responsibility to ensure adequate clearance for all components including space for and safe location of the fan, radiator, all lines, and wires. Check for possible movement, vibration, friction points, heat exposure and/or shifting of any and all components such as hoses, wires, and all other components including those that may otherwise be considered non-moving and/or unaffected by the installation (3.) The buyer is responsible for the entire installation of a mounting kit as the mounting kit is part of a custom process controlled by the buyer through their whole system design and directed installer as the installer evaluates, locates, routes, aligns, and tightens all components while determining if additional clamps, brackets, wear-liners, or other components may be required, beyond those included in the kit. Any additional items required, beyond those included in the kit, are to be provided at the expense of the buyer. (4.) The buyer is responsible for the development and communication of their whole system installation procedures, safety precautions, application, and use of the engine accessory mounting kit in their system, including efforts to maintain vehicle control and prevent pinch, wear, impact, and/or burn exposure on all hoses, wires, and other parts. (5.) The buyer is responsible for providing trained and experienced installation decision making with technical know-how to apply professional judgment that specifically applies to each individual installation. The buyers chosen installers must be qualified and experienced technicians that are familiar with the vehicle and accessory being mounted as well as the buyer's whole system design and installation procedures associated with the kit. (6.) The buyer is responsible for determining and achieving compliance to all regulatory issues that apply to the use of all products. (7.) The manufacturer reserves the right to make changes and/or improvements to any product at any time with or without notice.



CW Mill Equipment Co., Inc.
 14 Commerce Drive Sabetha, KS 66534
 Phone: (785) 284-3454
 Fax: (785) 284-3601
 Email: brackets@cwmill.com
 Website: www.cwkits.com

VFK241A-I6

2021-2024 Ford E-350-E-450 Cutaway Van
 7.3L V8 Gas w/ A/C, w/o OEM Dual Alternators

Requires 6-Groove Clutch
 Requires SAE Two-Bolt 'A' Flange Pump
 Recommend a 1.75 in.³ or 8 gal. Pump w/ 12hp Restriction

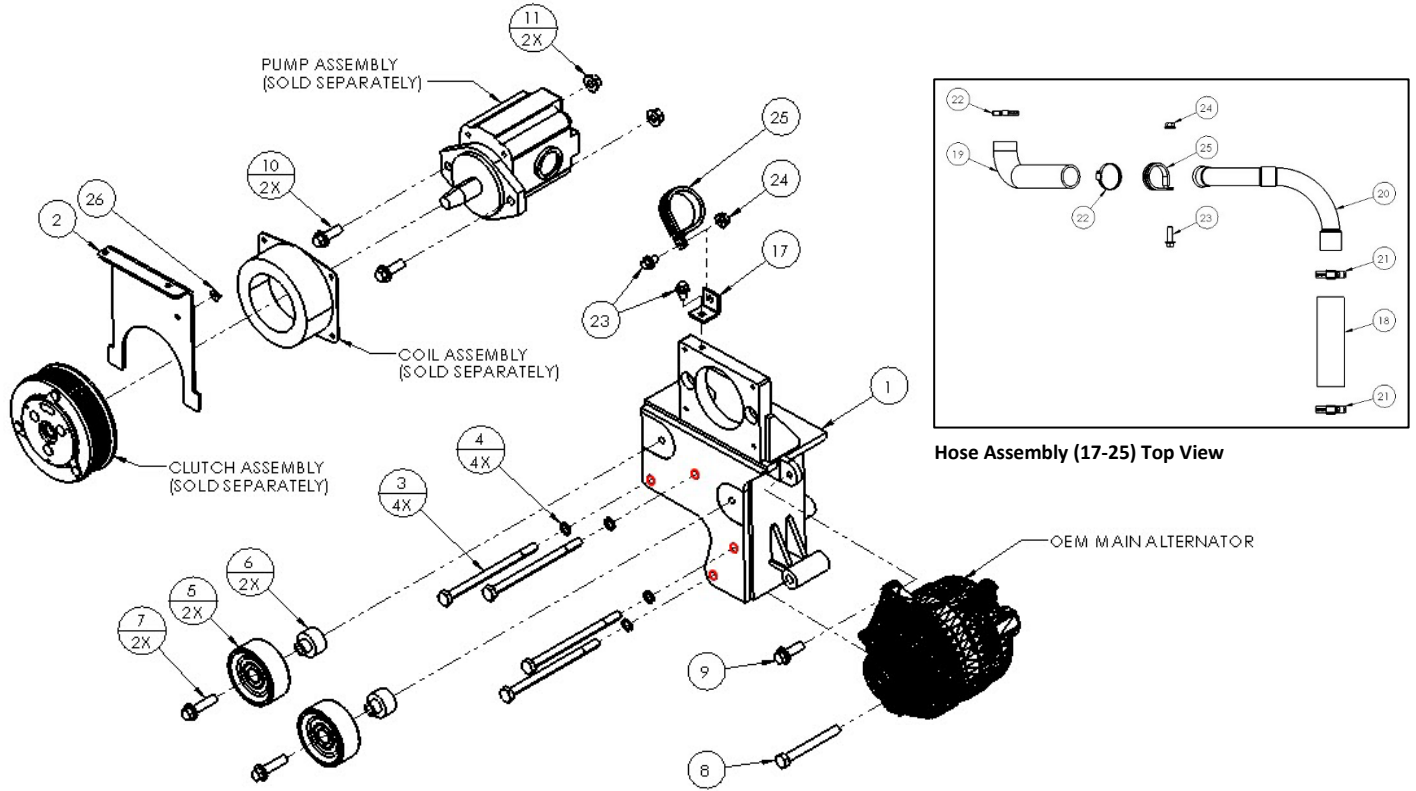

PARTS LIST							
Item	Part Number	Description	Qty.	Item	Part Number	Description	Qty.
Main Bracket				13	N/A	Heat Shrink	1
1	VFMB241A	Main Bracket	1	14	1011623	8mm x 12mm Flange Bolt	1
Air Cleaner Bracket				15	1013333	8mm Flange Nut	1
2	VFMB241-2	Air Cleaner Bracket	1	Belt			
Mounting Hardware (Main Bracket)				16	5061005	Dayco 6-Groove 100.5" Belt	1
3	1005275	10mm x 150mm Hex Bolts	4	Hose Assembly			
4	1003822	10mm Lock Washers	4	17	VFB241-3	Hose Bracket	1
Idler Pulley Assemblies				18	VFB241-2	1-3/4" ID x 7" Straight Rubber Hose	1
5	89007	Smooth Idler Pulleys	2	19	20626M	Modified Rubber Elbow	1
6	FMB241-1	Machined Bushings	2	20	VFB241-1	Steel Pipe	1
7	1006933	10mm x 40mm Flange Bolts	2	21	1006199	#28 Hose Clamps	2
Mounting Hardware (Main Alternator)				22	1016325	#24 Hose Clamps	2
8	N/A	OEM 10mm x 90mm Hex Bolt	1	23	1011623	8mm x 12mm Flange Bolts	2
9	1006927	10mm x 30mm Flange Bolt	1	24	1013333	8mm Flange Nut	1
Mounting Hardware (Clutch Pump)				25	1007886	#24 Adel Clamp	1
10	1006927	10mm x 30mm Flange Bolt	2	Air Duct Hardware			
11	1018204	10mm Flange Bolt	2	26	1016331	6mm Flange Nut	1
Wire Extension (Not Shown)							
12	N/A	Wire Extension	1				



CW Mill Equipment Co., Inc.

14 Commerce Drive Sabetha, KS 66534

Phone: (785) 284-3454

Fax: (785) 284-3601

Email: brackets@cwmill.com

Website: www.cwkits.com

VFK241A-I6

2021-2024 Ford E-350-E-450 Cutaway Van
7.3L V8 Gas w/ A/C, w/o OEM Dual Alternators

Requires 6-Groove Clutch
Requires SAE Two-Bolt 'A' Flange Pump
Recommend a 1.75 in.³ or 8 gal. Pump w/ 12hp Restriction



Air Cleaner Box Assembly (Cut at Red Lines)

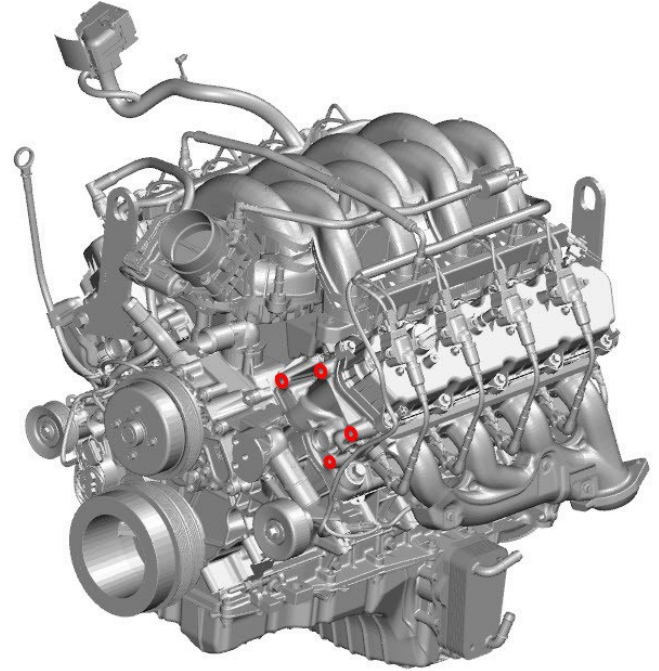

Mounting Locations

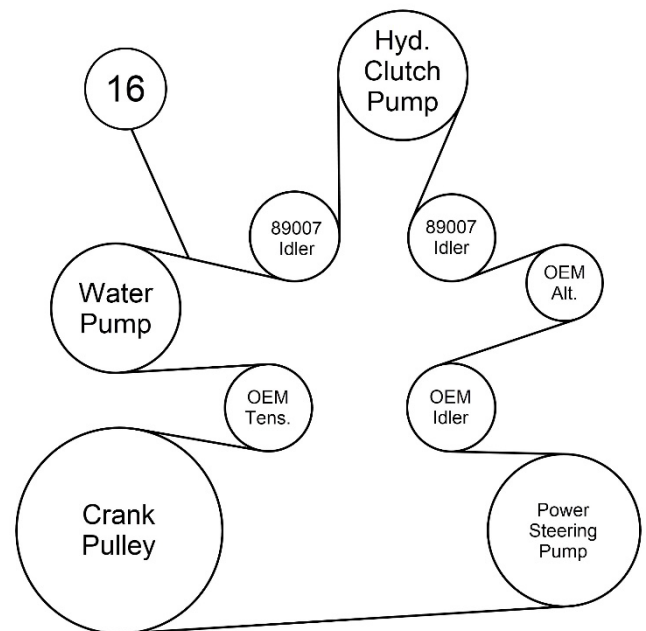

Belt Routing