



VRK30SD508-6

2022-2024 RAM ProMaster 1500-3500
3.6L V6 Gas, w/ A/C

For use w/ TM13, TM15 or TM16 Ear-Mount Compressor
Requires 6 or 8-Groove, 119mm Diameter Clutch
128% Overdrive Ratio w/ 119mm Diameter Clutch

INSTALLATION NOTES

(AUXILIARY A/C COMPRESSOR MOUNTING BRACKET/HARDWARE)

1. The buyer is responsible for providing trained and experienced installation decision making with technical know-how to apply professional judgment that specifically applies to each individual installation.
2. Be sure to read and understand all available information including but not limited to instructions, warnings, sale terms, and warranties for the vehicle and all system components prior to attempting installation.
3. Disconnect the negative battery cable. Battery is located under the driver's side floorboard. Remove the splash shield from underneath the passenger side of the van. After allowing the engine to cool, drain the engine coolant completely. The best way is to remove one of the lowest heater hoses at the front of the engine.
4. Remove both heater hoses connected to the lower radiator hose. Then, remove the complete lower radiator hose from the engine to the radiator, including the quick-disconnect at the radiator. Remove the OEM serpentine belt.
5. Remove the plug from the transmission bell housing to gain access to the ring gear. Use a pry bar through the hole in the bell housing to keep the engine from turning. Remove the crankshaft pulley bolt. Remove the plastic support clip holding the A/C line to the frame and discard. Install pulley (1) with bolt (2) and washer (3) finger tight. Make certain the pulley pilots into the engine damper. Rotate the pulley counter-clockwise until the pins make contact with the damper spokes. Torque bolt (2) to 220 ft/lbs.
6. Remove the A/C compressor from the engine (NOTE: Do not disconnect the A/C lines from the compressor). Support the compressor with a wire hook or other suitable tool. Remove the A/C compressor bracket from the engine. Install base plate bracket (4) with mounting hardware (5-7) at mounting locations [A-C]. Torque bolts (5-6) to 24 ft/lbs. Torque bolt (7) to 35 ft/lbs.
7. Remove the bolt holding the two steel heater hoses to the oil pan. Install the OEM compressor with OEM bolt (12) at the back of the compressor. Do not tighten completely. Place mounting bracket (8) over the OEM compressor. Install it with mounting hardware (10-11). Bolt (11) must go in the lower, most inward hole to avoid any contact with the steel heater hose. Tighten bolts (10-11) lightly. Then, torque them to 24-28 ft/lbs. Tighten OEM compressor bolt (12).
8. Reinstall the OEM belt to the same routing as OE.
9. Remove the rear nut from the air filter bracket and install brace (13) over the stud. Install adel clamp (14) over the A/C hose. Then, tighten the OEM nut and the clamp bolt (15) and nut (16) securely. This is to prevent the A/C line from impacting the add-on drive pulley and other moving components.
10. Install tensioner assembly (24-25), smooth idler pulley assembly (17-20), and grooved idler pulley assembly (21-23) with bolt (29) onto mounting bracket (8). Torque all bolts to 28 ft/lbs.
11. Install aftermarket A/C compressor with mounting hardware (26-28). Tighten securely.
12. Install belt (47) and route it as shown in the illustration.



VRK30SD508-6

2022-2024 RAM ProMaster 1500-3500
3.6L V6 Gas, w/ A/C

For use w/ TM13, TM15 or TM16 Ear-Mount Compressor
Requires 6 or 8-Groove, 119mm Diameter Clutch
128% Overdrive Ratio w/ 119mm Diameter Clutch

INSTALLATION NOTES (MODIFIED LOWER RADIATOR HOSE LINE ASSEMBLY)

1. Install the radiator quick-disconnect elbow (40) onto the radiator with the hose end facing inward. Install hose (39) marked with "RAD" and clamp (42) onto the coupler. Do not tighten.
2. Install the longer end of hose (37) marked with "ENG" and clamp (42) onto the engine. Do not tighten.
3. With clamps (42) installed over hoses (37-39), install steel pipes (35-36) with elbow (38). The nipple on steel pipe (36) should face inward.
4. Install adel clamp (32) over steel pipe (35). Install hose standoff (31) onto the back of idler bolt (29) with nut (30). Attach adel clamp (32) to hose standoff with bolt (33) and nut (34) loosely.
5. Adjust all hoses and pipes for best fit and clearances to the belt and any hot or moving parts. Tighten all hose clamps, adel clamp, nuts, and bolts securely.

NOTE: It is the installer's responsibility to make certain the hoses have adequate clearance to belts, and any other obstacles that might cause hose failures.

6. Using bolt (46) and spacers (44-45), secure the heater hoses to the oil pan as shown in image C (the 3/16" spacer (44) goes on top).
7. The hose in image D may need to be shortened approximately 1" for better fit and clearance. Use clamp (43) and tighten securely.
8. Install hose (41) with clamps (43) as shown in Image B. Tighten clamps securely.
9. Cut the hose coming from the reservoir for best fit and connect it to pipe (36). Use clamps (43).
10. Replace the engine coolant and reconnect the battery cable.
11. Trim the splash shield if necessary. Reinstall using OEM hardware.

CAUTION: Before starting the engine, check to make certain no wires, hoses, etc. that may have been disturbed during installation do not come in contact with any hot or moving parts. Properly refill any fluids that may have been drained. Check for leaks. Run the engine and check for proper belt tracking and clearance of any hoses, wires, etc. It is the installer's responsibility to correct/adjust any components, if necessary, before vehicle is put into service.

For use w/ TM13, TM15 or TM16 Ear-Mount Compressor
 Requires 6 or 8-Groove, 119mm Diameter Clutch
 128% Overdrive Ratio w/ 119mm Diameter Clutch

Mounting Hardware

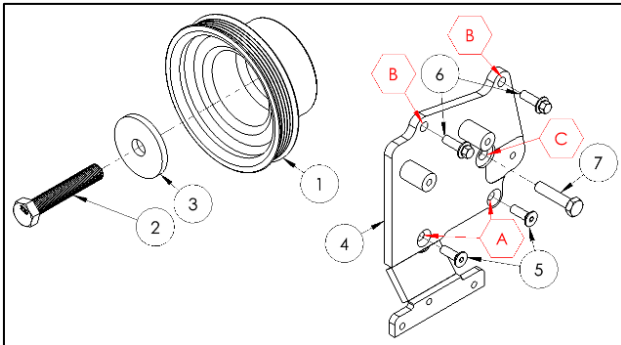

Add-on Pulley Assembly (1-3), Base Plate Bracket Assembly (4-7)

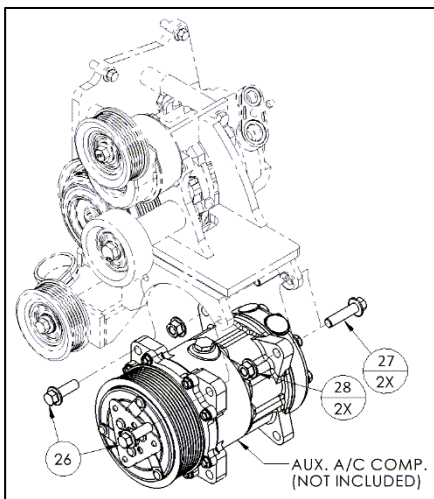
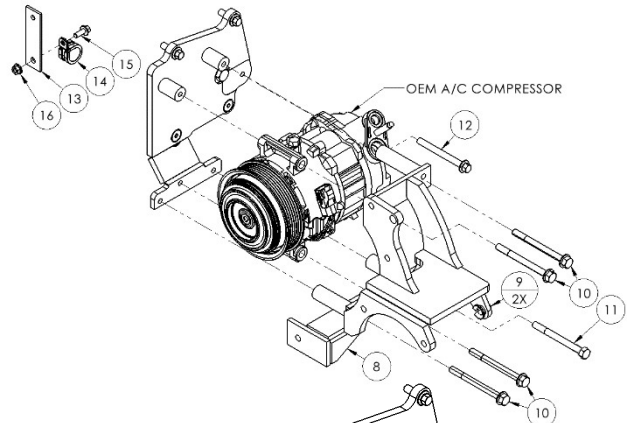

Auxiliary A/C Compressor Mounting Hardware (26-28)

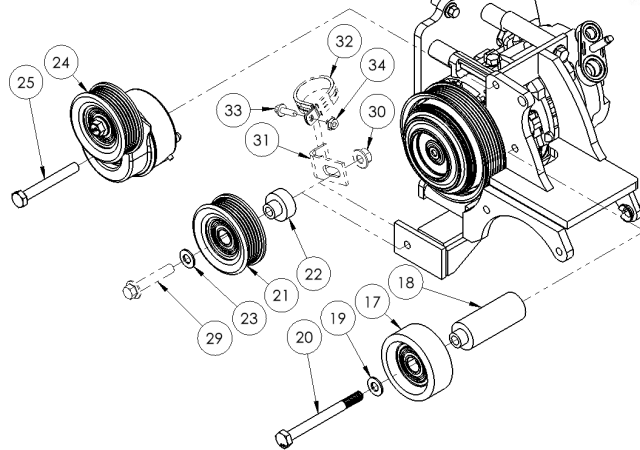

| PARTS LIST | | | | | | | |
|---|---------------|-------------------------------------|------|---|-------------|--|------|
| Item | Part Number | Description | Qty. | Item | Part Number | Description | Qty. |
| Add-on Pulley Assembly | | | | Smooth Idler Pulley Assembly | | | |
| 1 | VDPC306 | Add-on Pulley (6" Diameter) | 1 | 15 | 1016329 | M6-1.0 x 16mm 10.9Gr Hex Flg. Bolt | 1 |
| 2 | 1022530 | M16-1.5 x 90mm 10.9Gr Hex Bolt | 1 | 16 | 1016331 | M6-1.0 10.9Gr Hex Flg. Nut | 1 |
| 3 | 1022537 | M16 Thick Flat Washer | 1 | Grooved Idler Pulley Assembly | | | |
| Base Plate Bracket | | | | 17 | 89007 | Dayco Smooth Idler Pulley | 1 |
| 4 | VRMB301 | Base Plate Bracket | 1 | 18 | VDMB305 | Machined Idler Pulley Bushing (1.25" Dia.) | 1 |
| Base Plate Bracket Mounting Hardware | | | | 19 | 1007644 | 3/8" Flat Washer | 1 |
| 5 | 1022556 | M8-1.25 x 25mm 10.9Gr Torx FHSCS | 2 | 20 | 1005539 | M10-1.5 x 110mm 10.9Gr Hex Bolt | 1 |
| 6 | 1011887 | M8-1.25 x 25mm 10.9Gr Hex Flg. Bolt | 2 | Tensioner Assembly | | | |
| 7 | 1006630 | M10-1.5 x 45mm 10.9Gr Hex Bolt | 1 | 21 | 89051 | Dayco Grooved Idler Pulley | 1 |
| Auxiliary A/C Compressor Bracket | | | | 22 | VDMB306 | Machined Idler Pulley Bushing (1.25" Dia.) | 1 |
| 8 | VDMP30SD508-6 | Auxiliary A/C Compressor Bracket | 1 | 23 | 1007644 | 3/8" Flat Washer | 1 |
| 9 | 1011888A | M14 Slide Bushing (Installed) | 2 | 24 | 89260-051M | Custom Assembled & Modified Tensioner | 1 |
| Auxiliary A/C Compressor Bracket Mounting Hardware | | | | 25 | 1003980 | M10-1.5 x 80mm 10.9Gr Hex Bolt | 1 |
| 10 | 1011688 | M8-1.25 x 90mm 10.9Gr Hex Flg. Bolt | 4 | Auxiliary A/C Compressor Mounting Hardware | | | |
| 11 | 1022549 | M8-1.25 x 85mm 10.9Gr Hex Bolt | 1 | 26 | 1006927 | M10-1.5 x 30mm 10.9Gr Hex Flg. Bolt | 2 |
| 12 | N/A | OEM A/C Compressor Bolt | 1 | 27 | 1006933 | M10-1.5 x 40mm 10.9Gr Hex Flg. Bolt | 2 |
| A/C Line Hose Clamp Assembly | | | | 28 | 1018204 | M10-1.5 10.9Gr Hex Flg. Nut | 2 |
| 13 | VDMB3013 | A/C Line Brace | 1 | | | | |
| 14 | 1005112 | #12 Adel Clamp | 1 | | | | |

For use w/ TM13, TM15 or TM16 Ear-Mount Compressor
 Requires 6 or 8-Groove, 119mm Diameter Clutch
 128% Overdrive Ratio w/ 119mm Diameter Clutch

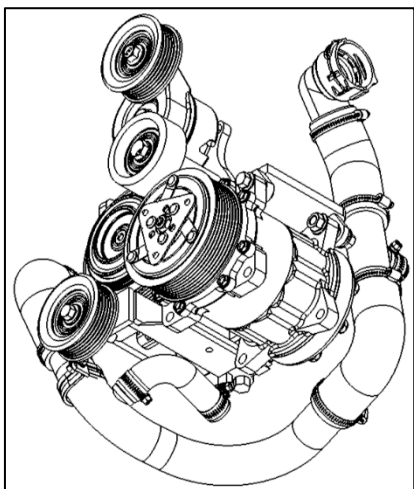
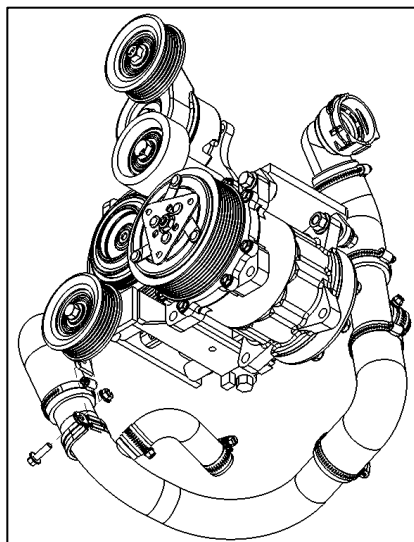

Lower Radiator Hose Line Assembly
 (Reference Only)

**Lower Radiator Hose Line Assembly
 (VR30HK)**

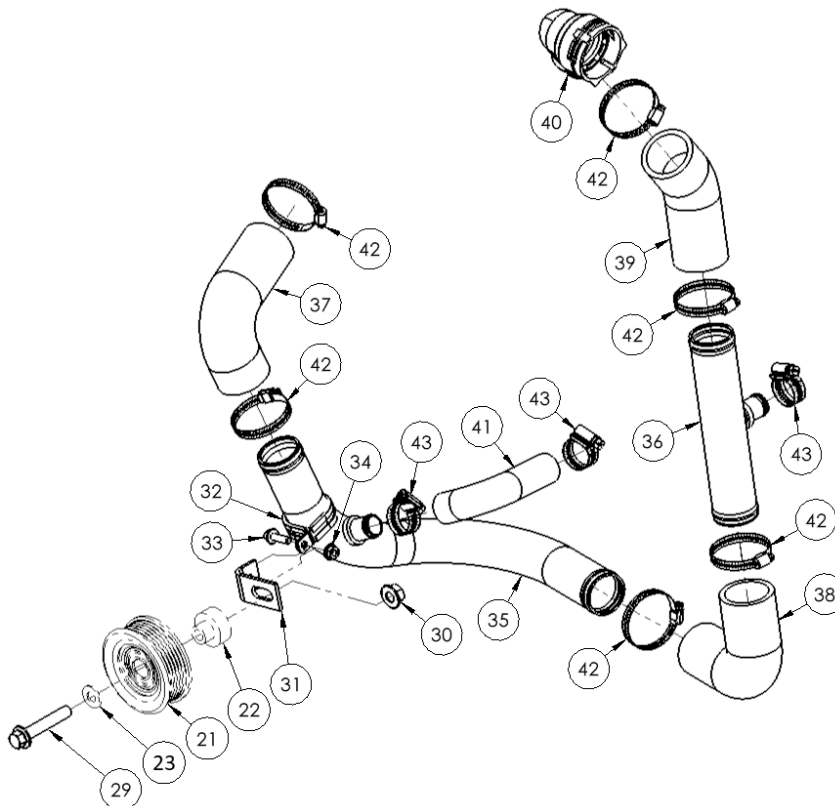

PARTS LIST

| Item | Part Number | Description | Qty. | Item | Part Number | Description | Qty. |
|--|-------------|-------------------------------------|------|--|-------------|---|------|
| Radiator Hose Support Assem. (Attaches to Grooved Idler Assem.) | | | | 38 | VRMB306 | 1-1/2" 90° Rubber Elbow | 1 |
| 29 | 1006934 | M10-1.5 x 50mm 10.9Gr Hex Flg. Bolt | 1 | 39 | VRMB307 | 1-1/2" 40° Rubber Elbow (Radiator) | 1 |
| 30 | 1018204 | M10-1.5 10.9Gr Hex Flg. Nut | 1 | 40 | 1022510 | 90° Quick-Disconnect Elbow | 1 |
| 31 | VRMB302 | Hose Support Brace | 1 | 41 | VRMB308 | 3/4" 90° Rubber Elbow | 1 |
| 32 | 1007886 | #24 Adel Clamp | 1 | 42 | 1016325 | #24 Hose Clamp | 6 |
| 33 | 1016330 | M6-1.0 x 20mm 10.9Gr Hex Flg. Bolt | 1 | 43 | 1006198 | #10 Hose Clamp (Qty. 2 Not Shown) | 5 |
| 34 | 1016331 | M6-1.0 10.9Gr Hex Flg. Nut | 1 | Heater Hose Support Brace Hardware (Shown in Image C) | | | |
| Radiator Hose Line Assembly | | | | 44 | SP64-0.1875 | 13/32" ID, 3/4" OD, 3/16" Length Spacer | 1 |
| 35 | VRMB303 | 1-1/2" Steel Pipe (Two Bends) | 1 | 45 | SP64-0.25 | 13/32" ID, 3/4" OD, 1/4" Length Spacer | 1 |
| 36 | VRMB304 | 1-1/2" Steel Pipe (Straight) | 1 | 46 | 1011887 | M8-1.25 x 25mm 10.9Gr Hex Flg. Bolt | 1 |
| 37 | VRMB305 | 1-1/2" 70° Rubber Elbow (Engine) | 1 | | | | |

Belt Routing

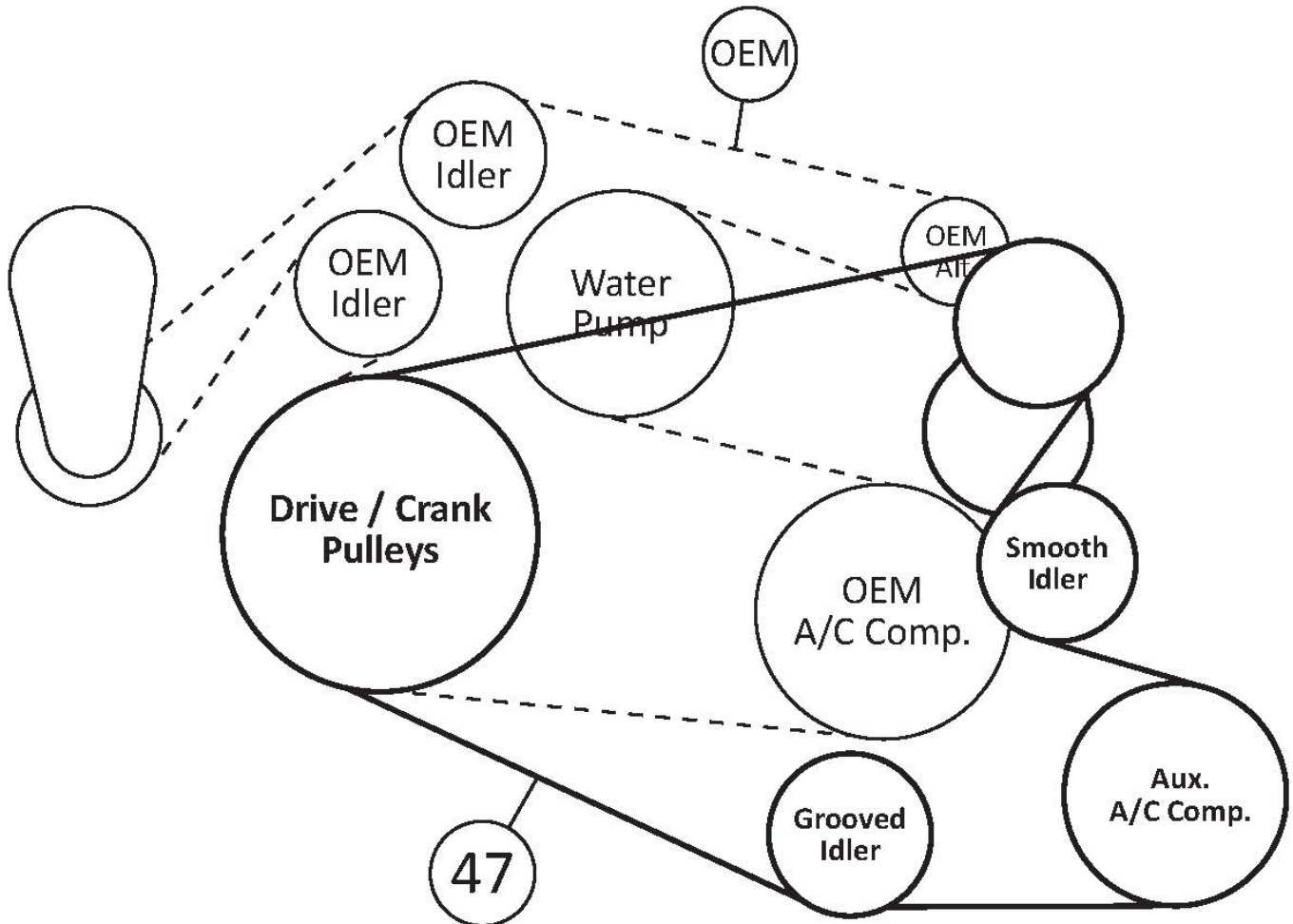

| PARTS LIST | | | |
|---|-------------|-------------------------------|------|
| Item | Part Number | Description | Qty. |
| Auxiliary A/C Compressor Drive Belt (Only One is Supplied) | | | |
| 47 | 5060555 | Dayco 6-Groove, 55.5" Belt | 1 |
| 47 | K060555 | Gates 6-Groove, 55.5" Belt | 1 |
| 47 | 555K6 | Imperial 6-Groove, 55.5" Belt | 1 |
| 47 | 6PK1410 | Metric 6-Groove, 1410mm Belt | 1 |

VRK30SD508-6

2022-2024 RAM ProMaster 1500-3500
3.6L V6 Gas, w/ A/C

For use w/ TM13, TM15 or TM16 Ear-Mount Compressor
Requires 6 or 8-Groove, 119mm Diameter Clutch
128% Overdrive Ratio w/ 119mm Diameter Clutch

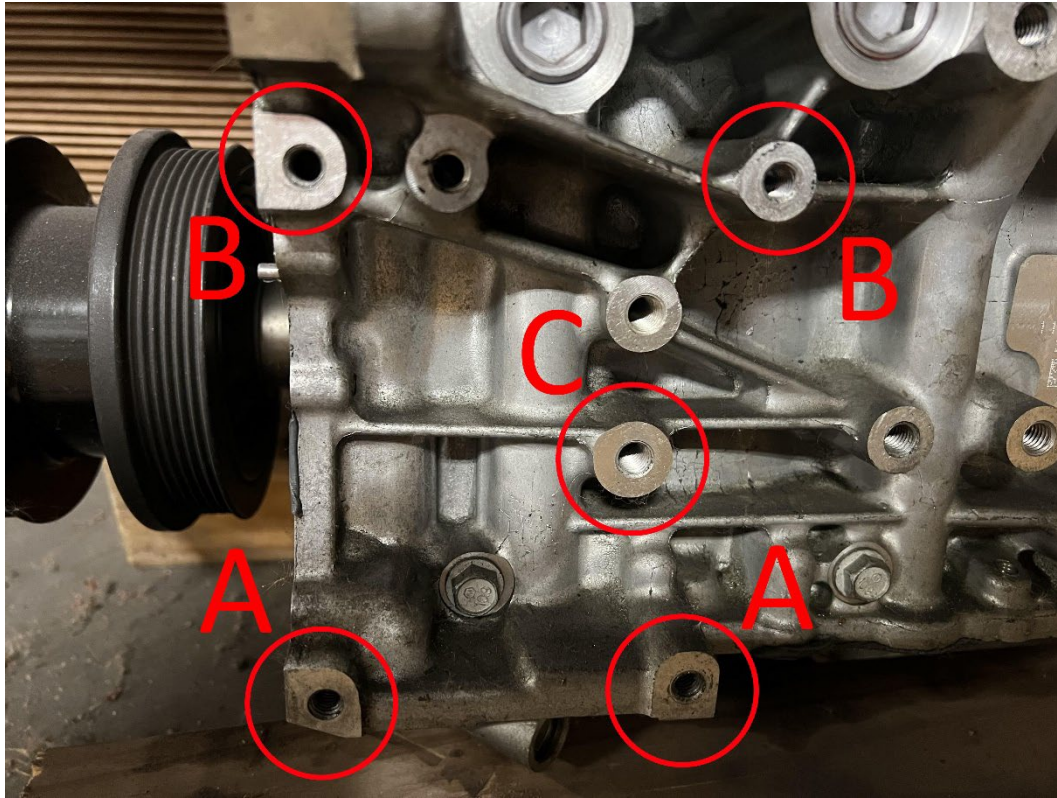

Image A

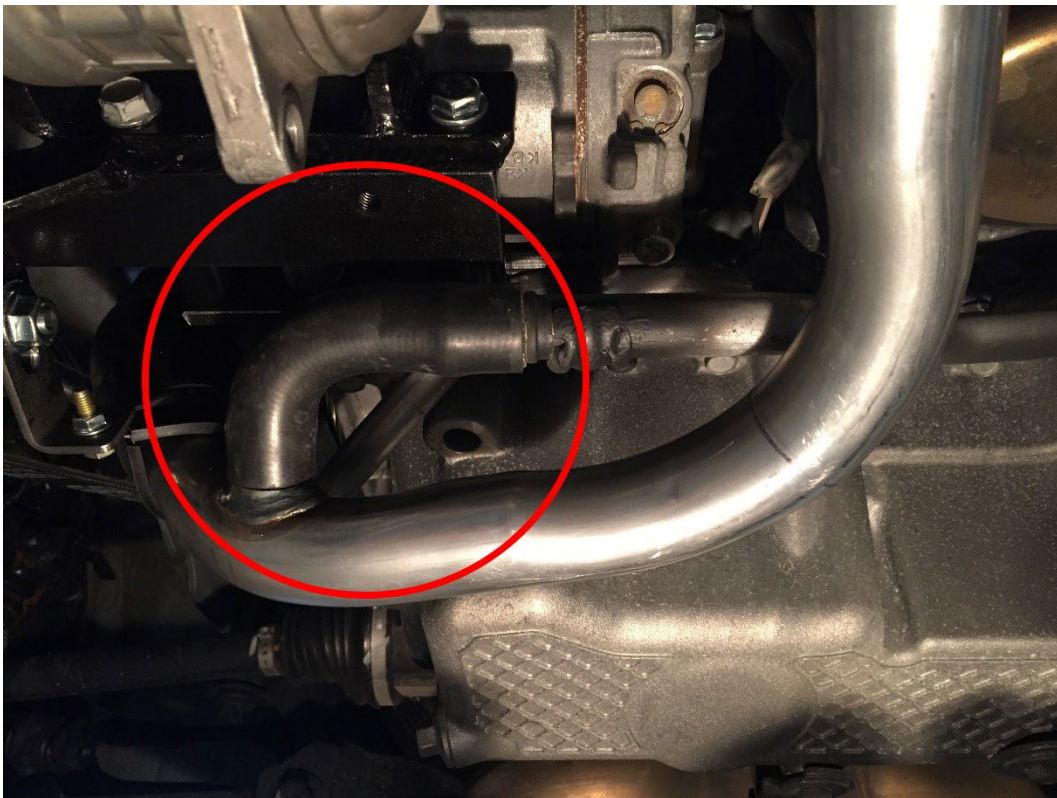

Image B

VRK30SD508-6

2022-2024 RAM ProMaster 1500-3500
3.6L V6 Gas, w/ A/C

For use w/ TM13, TM15 or TM16 Ear-Mount Compressor
Requires 6 or 8-Groove, 119mm Diameter Clutch
128% Overdrive Ratio w/ 119mm Diameter Clutch



Image C

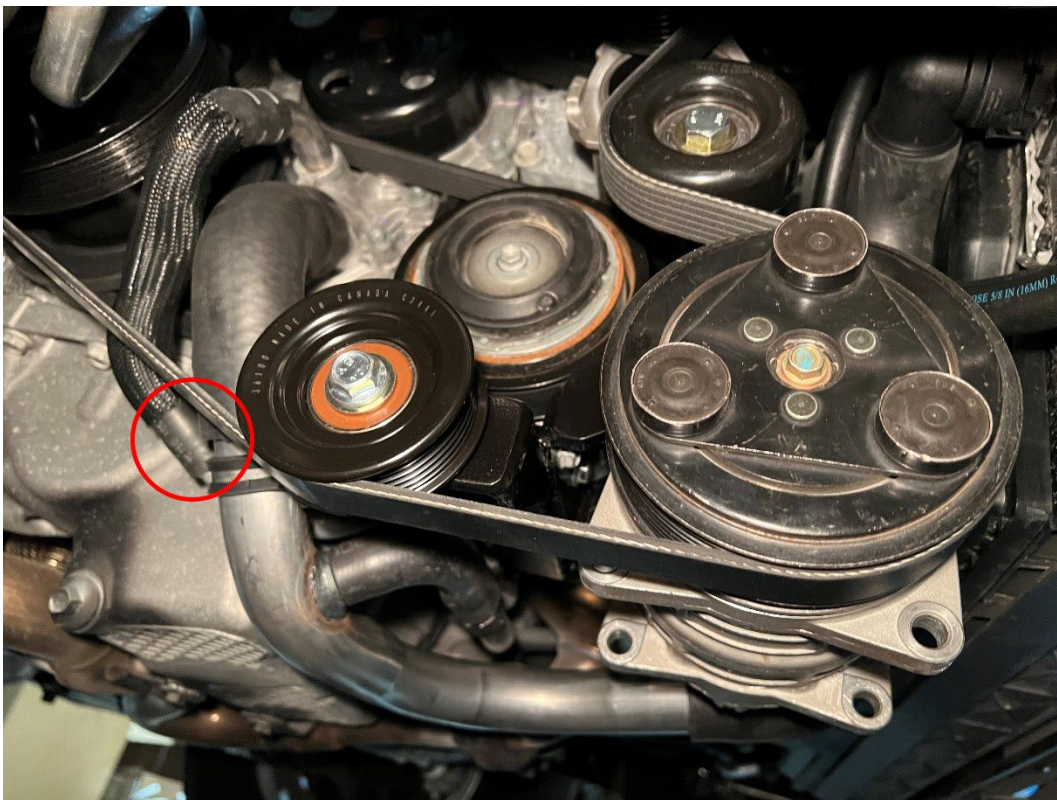

Image D



CW Mill Equipment Co., Inc.
14 Commerce Drive Sabetha, KS 66534
Phone: (785) 284-3454
Fax: (785) 284-3601
Email: brackets@cwmill.com
Website: www.cwkits.com

VRK30SD508-6

2022-2024 RAM ProMaster 1500-3500
3.6L V6 Gas, w/ A/C

**For use w/ TM13, TM15 or TM16 Ear-Mount Compressor
Requires 6 or 8-Groove, 119mm Diameter Clutch
128% Overdrive Ratio w/ 119mm Diameter Clutch**

INSTALLER NOTES / DISCLAIMER

CW Mill Equipment Co., Inc. Mounting Kit and Mounting Kit Component Disclaimer: (1.) Due to the custom nature and variation of all add-on systems of this type, no complete system kits are offered by the manufacturer, and any group of parts marketed as a kit is limited to only the individually defined parts in that specific kit. The system designer's rotating accessory components are not included, offered, or fully known by the manufacturer. In addition to the absence of the rotating accessory system, other potential components such as additional clamps, brackets, wear liners, hardware, or other items that may be required by the system designer must be identified and supplied by the actual system designer. (2.) Due to vehicle manufacturer's assembly tolerances, production changes, and installation variances, it is the buyer's responsibility to ensure adequate clearance for all components including space for and safe location of the fan, radiator, all lines, and wires. Check for possible movement, vibration, friction points, heat exposure and/or shifting of any and all components such as hoses, wires, and all other components including those that may otherwise be considered non-moving and/or unaffected by the installation (3.) The buyer is responsible for the entire installation of a mounting kit as the mounting kit is part of a custom process controlled by the buyer through their whole system design and directed installer as the installer evaluates, locates, routes, aligns, and tightens all components while determining if additional clamps, brackets, wear-liners, or other components may be required, beyond those included in the kit. Any additional items required, beyond those included in the kit, are to be provided at the expense of the buyer. (4.) The buyer is responsible for the development and communication of their whole system installation procedures, safety precautions, application, and use of the engine accessory mounting kit in their system, including efforts to maintain vehicle control and prevent pinch, wear, impact, and/or burn exposure on all hoses, wires, and other parts. (5.) The buyer is responsible for providing trained and experienced installation decision making with technical know-how to apply professional judgment that specifically applies to each individual installation. The buyer's chosen installers must be qualified and experienced technicians that are familiar with the vehicle and accessory being mounted as well as the buyer's whole system design and installation procedures associated with the kit. (6.) The buyer is responsible for determining and achieving compliance to all regulatory issues that apply to the use of all products. (7.) The manufacturer reserves the right to make changes and/or improvements to any product at any time with or without notice.