



VFLMK27J180-6-7.5

2019-2022 Freightliner/Mercedes-Benz Sprinter 2500-4500
3.0L V6 Diesel w/-w/o A/C, w/o Mercedes-Benz N62 or N63 Options

Requires 6-Groove Pulley
For use w/ J180 Style Alternator
375% Overdrive Ratio w/ 2" Diameter Pulley

Wrenches are available and suggested for removal and retorquing the harmonic balancer bolts. PART# VFL23WR-1 & VFL23WR-2. These are sold separately.

INSTALLATION NOTES

1. The buyer is responsible for providing trained and experienced installation decision making with technical know-how to apply professional judgment that specifically applies to each individual installation.
2. Be sure to read and understand all available information including but not limited to instructions, warnings, sale terms, and warranties for the vehicle and all system components prior to attempting installation.
3. Remove harmonic balancer bolt using wrench (PART# VFL23WR-1 (sold separately)).
4. Install pulley adaptor (1) using bolt (3), OEM spacer, and set screws (4). Torque harmonic balancer bolt to 280 ft/lbs. using wrench (PART# VFL23WR-2 (sold separately)). Cross-torque set screws to the following specs (a mild-grade of Loctite is advisable to use):
 - a. 10 in/lbs.
 - b. 30 in/lbs.
 - c. 60 in/lbs.
 - d. 90 in/lbs.
 - e. 120 in/lbs.

Install drive pulley (2) with bolts (5) to pulley adaptor (1).

5. Install main bracket (6) with bolts (8) at location [A]. Check for gaps at location [B]. Remove bracket (6) and install appropriate shims (20-22) at location [B] if necessary. Remove the two lower bolts from the OEM alternator. Reinstall main bracket (6) with bolts (9) and selected shims (20-22) (if used) at location [B]. Then, install brace (7) onto main bracket (6) using bolts (8) (do not tighten). Install the two OEM lower alternator bolts back into alternator through the brace (7). Torque bolts (8-9) and two OEM lower alternator bolts to 20 ft/lbs.
6. Install FEAD brace (10) to mounting bracket (6) using bolts (11), and to the engine at location [C] using bolt (12) and spacer (13).
7. Install smooth idler assembly (16-19) onto FEAD brace (10).
8. Install belt tensioner (14) using bolt (15) onto FEAD brace (10).
9. Install auxiliary alternator using bolts (23-28).
10. Install new drive belt (29). Fan shroud may need to be trimmed for clearance with the drive belt and tensioner.

WARNING: Before starting the engine. Check to make certain no wires, hoses, etc. that may have been disturbed during installation do not come in contact with any hot or moving parts. Run the engine and check for proper belt tracking, adjust if necessary. It is the installer's responsibility to make sure that all components are in proper position and alignment.

Requires 6-Groove Pulley
 For use w/ J180 Style Alternator
 375% Overdrive Ratio w/ 2" Diameter Pulley

Parts List

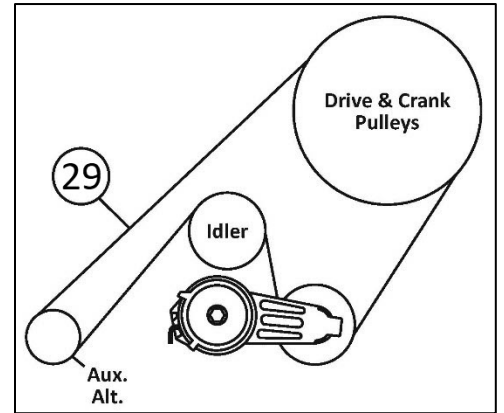
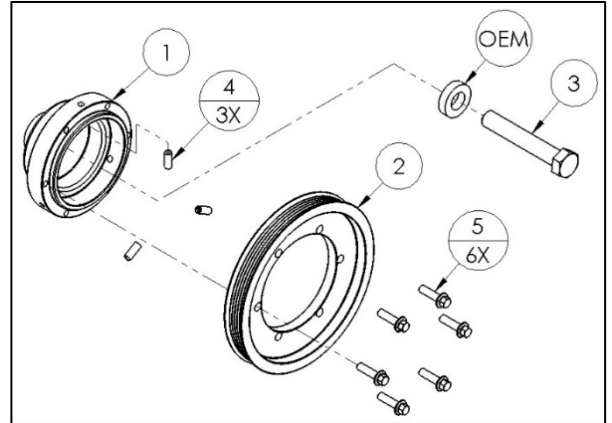
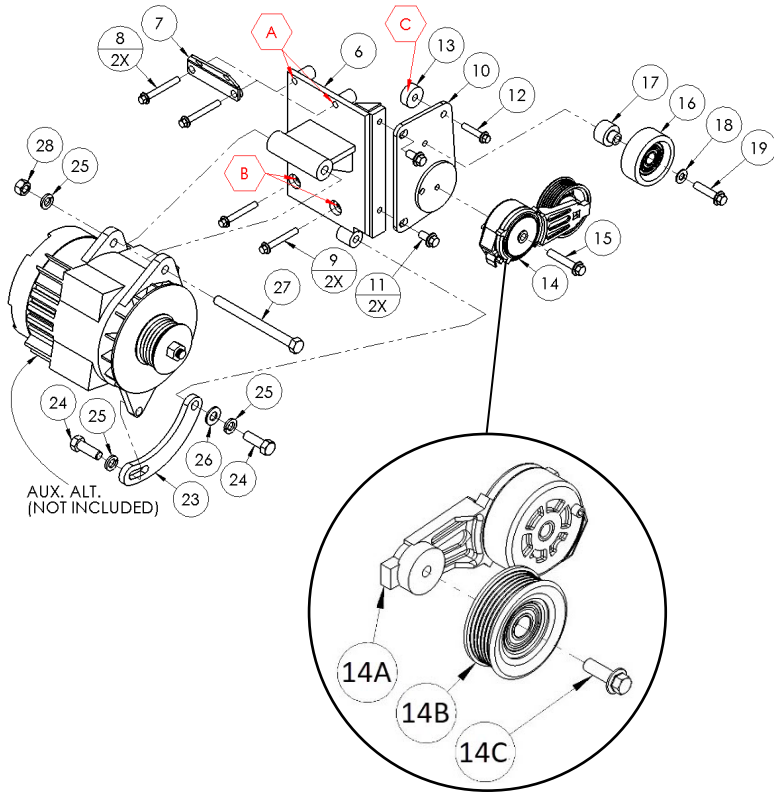

PARTS LIST								
Item	Part Number	Description	Qty.	Item	Part Number	Description	Qty.	
Add-on Drive Pulley Adaptor				14b	89051	Dayco 6-Groove Idler Pulley	1	
1	VFLPA23	Add-on Drive Pulley Adaptor	1	14c	N/A	OEM Dayco 89203 Idler Pulley Bolt	1	
Add-on Drive Pulley				15	1018225	M10-1.5 x 55mm 10.9Gr Hex Flg. Bolt	1	
2	VFLPC236-7.75	Add-on Drive Pulley (7.5" Diameter of Grooves)	1	Smooth Idler Pulley Assembly				
Add-on Drive Pulley Mounting Hardware				16	89007	Dayco Smooth Idler Pulley	1	
3	1013313	M18-1.5 x 110mm 10.9Gr Hex Bolt	1	17	VFLMB272	Machined Idler Bushing (1-1/4" Diameter)	1	
4	1013315	M8-1.25 x 20mm Set Screw	3	18	1007644	3/8" USS Flat Washer	1	
5	1013349	M8-1.25 x 30mm 10.9Gr Hex Flg. Bolt	6	19	1006630	M10-1.5 x 45mm 10.9Gr Hex Bolt	1	
Auxiliary Alternator Mounting Bracket				Mounting Bracket Shims (Not Shown)				
6	VFLMP27J180-6	Auxiliary Alternator Mounting Bracket	1	20	1011653	.005" Shim	2	
Auxiliary Alternator Mounting Bracket Support Brace				21	1011656	.010" Shim	2	
7	VFLMB232	Support Brace (Attaches to OEM Alternator)	1	22	1018227	.020" Shim	2	
Auxiliary Alternator Mounting Bracket Mounting Hardware				Auxiliary Alternator Mounting Hardware				
8	1022522	M8-1.25 x 65mm 10.9Gr Hex Flg. Bolt	2	23	VFLMB27J180	J-180 Alternator Slide	1	
9	1018001	M8-1.25 x 60mm 10.9Gr Hex Flg. Bolt	2	24	1013337	1/2"-13 x 1-1/2" NC Gr5 Hex Bolt	2	
Auxiliary Alternator FEAD Brace				25	1010318	1/2" Lock Washer	3	
10	VFLMB271	Auxiliary Alternator FEAD Brace	1	26	1006931	1/2" Flat Washer	1	
Auxiliary Alternator FEAD Brace Mounting Hardware				27	1006120	1/2"-13 x 6" NC Gr5 Hex Bolt	1	
11	1008390	M10-1.5 x 20mm 10.9Gr Hex Flg. Bolt	2	28	1018231	1/2"-13 NC Gr5 Hex Nut	1	
12	1018223	M8-1.25 x 40mm 10.9Gr Hex Flg. Bolt	1	Belt (Only One Belt is Supplied)				
13	SP125-.500	1/2" Spacer (1-1/4" Diameter)	1	29	5060510	Dayco 6-Groove 51.0" Belt	1	
Tensioner Assembly					K060509	Gates 6-Groove 50.9" Belt	1	
14	89203-051	Custom Assembled Tensioner	1		6PK1295	Bando 6-Groove 1295mm Belt	1	
14a	89203	Dayco Tensioner Arm	1					

Mounting Locations

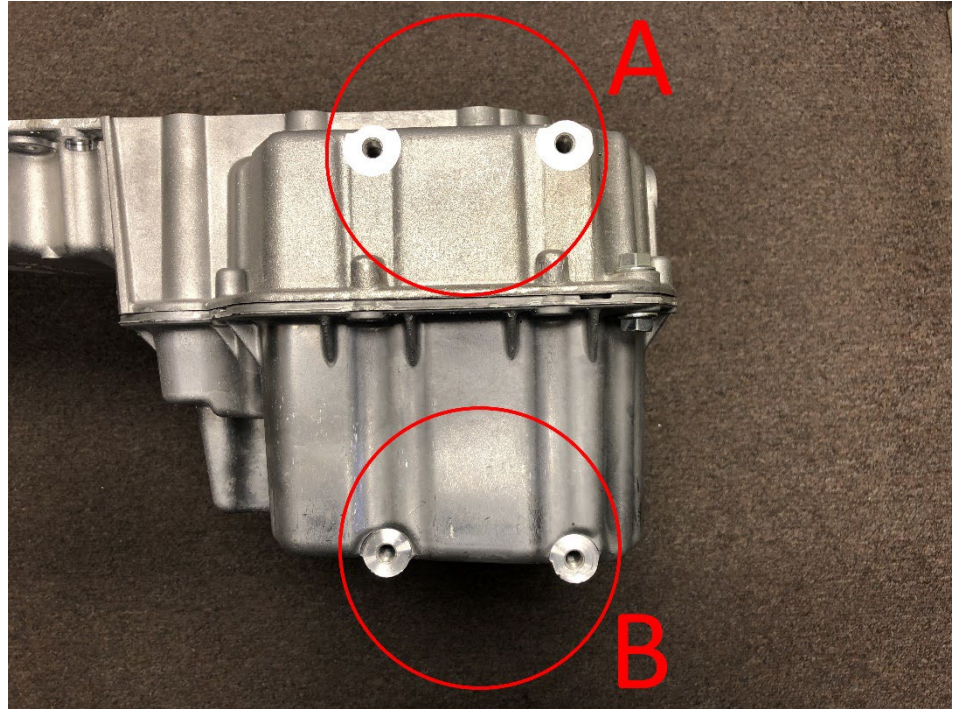

Mounting Locations [A,B] (Oil Pan)

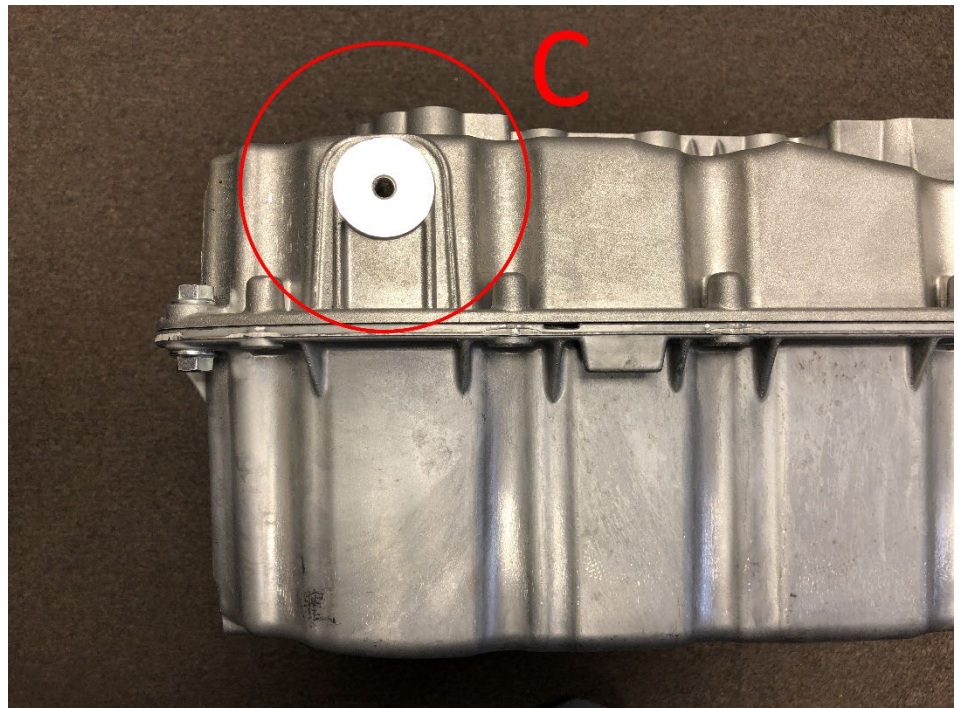

Mounting Location [C] (Oil Pan)



CW Mill Equipment Co., Inc.
14 Commerce Drive Sabetha, KS 66534
Phone: (785) 284-3454
Fax: (785) 284-3601
Email: brackets@cwmill.com
Website: www.cwkits.com

VFLMK27J180-6-7.5

2019-2022 Freightliner/Mercedes-Benz Sprinter 2500-4500
3.0L V6 Diesel w/-w/o A/C, w/o Mercedes-Benz N62 or N63 Options

Requires 6-Groove Pulley
For use w/ J180 Style Alternator
375% Overdrive Ratio w/ 2" Diameter Pulley

NOTES

CW Mill Equipment Co., Inc. Mounting Kit and Mounting Kit Component Disclaimer: (1.) Due to the custom nature and variation of all add-on systems of this type, no complete system kits are offered by the manufacturer, and any group of parts marketed as a kit is limited to only the individually defined parts in that specific kit. The system designer's rotating accessory components are not included, offered, or fully known by the manufacturer. In addition to the absence of the rotating accessory system, other potential components such as additional clamps, brackets, wear liners, hardware, or other items that may be required by the system designer must be identified and supplied by the actual system designer. (2.) Due to vehicle manufacturer's assembly tolerances, production changes, and installation variances, it is the buyer's responsibility to ensure adequate clearance for all components including space for and safe location of the fan, radiator, all lines, and wires. Check for possible movement, vibration, friction points, heat exposure and/or shifting of any and all components such as hoses, wires, and all other components including those that may otherwise be considered non-moving and/or unaffected by the installation (3.) The buyer is responsible for the entire installation of a mounting kit as the mounting kit is part of a custom process controlled by the buyer through their whole system design and directed installer as the installer evaluates, locates, routes, aligns, and tightens all components while determining if additional clamps, brackets, wear-liners, or other components may be required, beyond those included in the kit. Any additional items required, beyond those included in the kit, are to be provided at the expense of the buyer. (4.) The buyer is responsible for the development and communication of their whole system installation procedures, safety precautions, application, and use of the engine accessory mounting kit in their system, including efforts to maintain vehicle control and prevent pinch, wear, impact, and/or burn exposure on all hoses, wires, and other parts. (5.) The buyer is responsible for providing trained and experienced installation decision making with technical know-how to apply professional judgment that specifically applies to each individual installation. The buyers chosen installers must be qualified and experienced technicians that are familiar with the vehicle and accessory being mounted as well as the buyer's whole system design and installation procedures associated with the kit. (6.) The buyer is responsible for determining and achieving compliance to all regulatory issues that apply to the use of all products. (7.) The manufacturer reserves the right to make changes and/or improvements to any product at any time with or without notice.