

## INSTALLATION NOTES

---

1. The buyer is responsible for providing trained and experienced installation decision making with technical know-how to apply professional judgment that specifically applies to each individual installation.
2. Be sure to read and understand all available information including but not limited to instructions, warnings, sales terms, and warranties for the vehicle and all system components prior to attempting installation.
3. Disconnect the battery and drain engine coolant enough to remove the upper radiator hose without losing coolant. Remove the upper radiator hose at the engine. Using a 1/2" ratchet or other suitable tool, depress the tensioner and remove the serpentine belt. Remove the OEM idler from location A. It will be reused. Remove the bolts at locations C, D, and E. Install bracket (1) onto the engine using bolts (4) at locations C, D, and E. (Do not tighten) Install brace (2) with bolt (6) at location B, and bolts (5) into bracket (1). With all bolts installed finger tight, torque bolts (4) to 25 ft. lbs. Then torque bolt (6) to 40 ft. lbs. and bolts (5) to 25 ft. lbs.

**NOTE: On vehicles with black composite valve covers, it will be necessary to trim some plastic from the lower front portion of the valve cover for belt clearance.**

4. Disconnect the engine fan wire and remove the plastic wire support.
5. Remove bolts from locations F, G, and H. Install stud (15) at location H. Then, install idler bracket (14) using bolts (16) at locations F and G, install coupler nut (19) at location H. Install the O.E.M. idler that was removed onto bracket (14) using bushing (17) and bolt (18). Install idler (8) at location A with bolt (10) and washer (9). Install belt guard (3) with bolts (7). Do not tighten at this time. Install the pump onto the bracket (1) with bolts (12) and lock washers (13). Reinstall radio noise suppressor to top of bracket with bolt (7). Align both sides of clutch with the drive pulley using a good quality straight edge and then tighten bolts (12). Install the belt (11) as shown in the belt routing diagram. Adjust the belt guard (3) to obtain 1/8" to 1/4" clearance then tighten bolts (7). Connect the fan wire, and install the new fan wire support (20) with bolt (21) at location H. The grommet will need to be removed from the OE wire support and installed into the new wire support (20).
6. Install the upper radiator hose extension (23) using O.E.M. hose clamp onto the thermostat housing. Then, install the upper radiator hose onto it using coupler (22) and hose clamps (24).
7. Replace the engine coolant and connect the battery. Make certain all wires and hoses disturbed during installation do not come in contact with any hot or moving parts. Run the engine and check for proper belt tracking.

**CAUTION:** Before starting the engine, check to make certain no wires, hoses, etc. that may have been disturbed during installation do not come in contact with any hot or moving parts. Run the engine and check for proper belt tracking, adjust if necessary.



# CW Mill Equipment Co., Inc.

14 Commerce Drive Sabetha, KS 66534

Phone: (785) 284-3454

Fax: (785) 284-3601

Email: brackets@cwmill.com

Website: [www.cwkits.com](http://www.cwkits.com)

**MOUNTING KITS**

# FMK49A-I6LAD

2017-2022 Ford F-250-F-350 Super Duty

6.2L V8 Gas w/ A/C

Requires SAE Two-Bolt 'A' Flange Pump, 6-Groove Clutch  
Recommended 1.75 in<sup>3</sup> or 8 gal. Pump w/ 12hp Restriction

**NOTE: Must Use Rear Ported Pump**

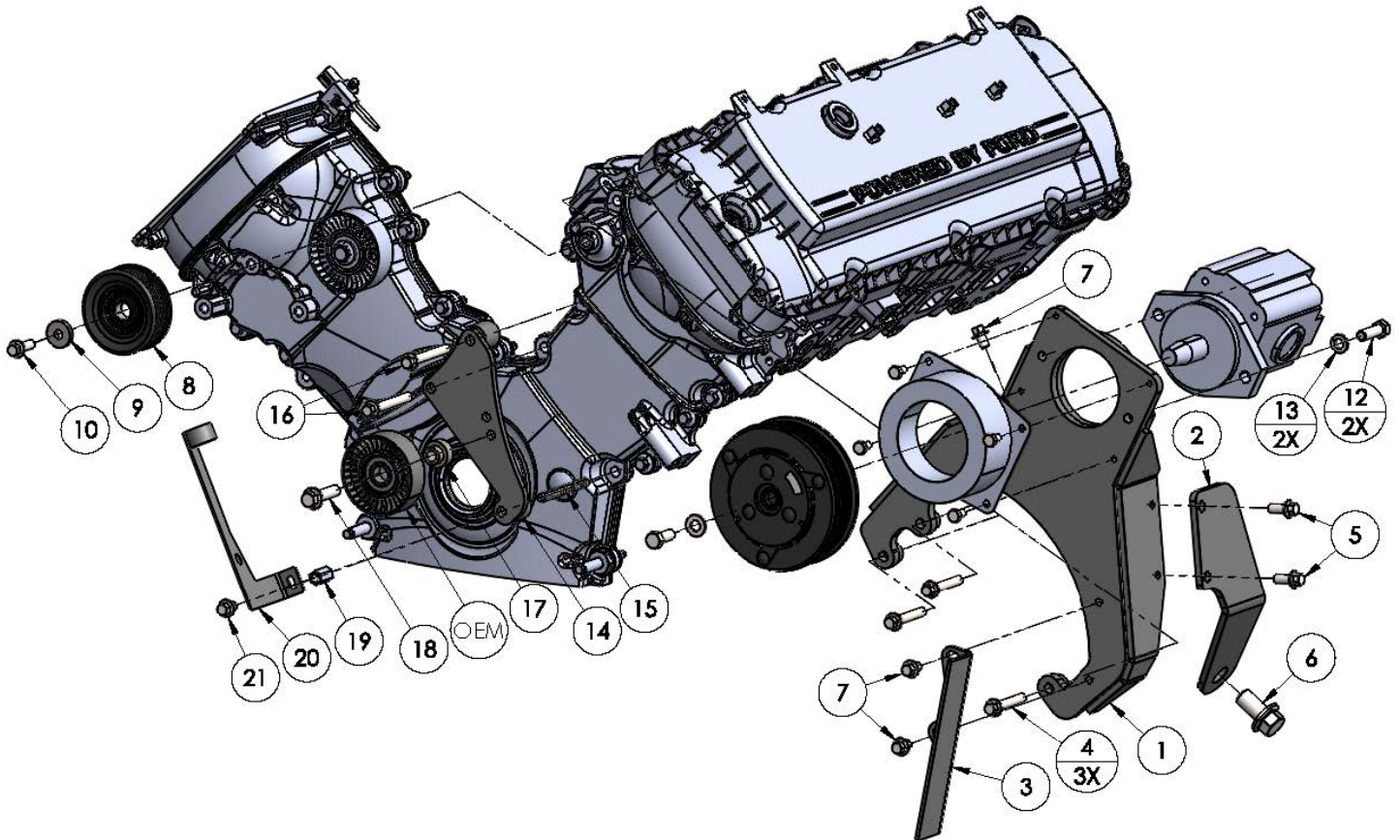

## PARTS LIST

- |                           |                                 |
|---------------------------|---------------------------------|
| 1. FMP48A-I6 (1)          | 12. 3/8 x 1-1/4 Bolt (2)        |
| 2. FMB481-I6 (1)          | 13. 3/8 Lock Washer (2)         |
| 3. FMB482-I6 (1)          | 14. FMB493-I6 (Rev. A) (1)      |
| 4. 8mm x 50mm Flange (3)  | 15. 8mm x 80mm Set Screw (1)    |
| 5. 8mm x 20mm Flange (2)  | 16. 8mm x 65mm Flange (2)       |
| 6. 16mm x 30mm Flange (1) | 17. CMB3867 (1)                 |
| 7. 8mm x 12mm Flange (3)  | 18. 10mm x 40mm Flange (1)      |
| 8. 89051 Dayco (1)        | 19. 8mm x 7/8" Coupling Nut (1) |
| 9. FMB483-I6 (1)          | 20. FMB494-I6 (1)               |
| 10. 8mm x 25mm Flange (1) | 21. 8mm x 12mm Flange (1)       |
| 11. 5061265 Dayco (1)     |                                 |

### Items (22-24) Not Shown

- 22. DMB402(1-1/2" Coupler) (1)
- 23. FMB485-I6 Hose (1)
- 24. #24 Hose Clamp (2)



**CW Mill Equipment Co., Inc.**  
 14 Commerce Drive Sabetha, KS 66534  
 Phone: (785) 284-3454  
 Fax: (785) 284-3601  
 Email: brackets@cwmill.com  
 Website: [www.cwkits.com](http://www.cwkits.com)

**MOUNTING KITS**

# FMK49A-I6LAD

2017-2022 Ford F-250-F-350 Super Duty  
 6.2L V8 Gas w/ A/C

Requires SAE Two-Bolt 'A' Flange Pump, 6-Groove Clutch  
 Recommended 1.75 in<sup>3</sup> or 8 gal. Pump w/ 12hp Restriction

**NOTE: Must Use Rear Ported Pump**

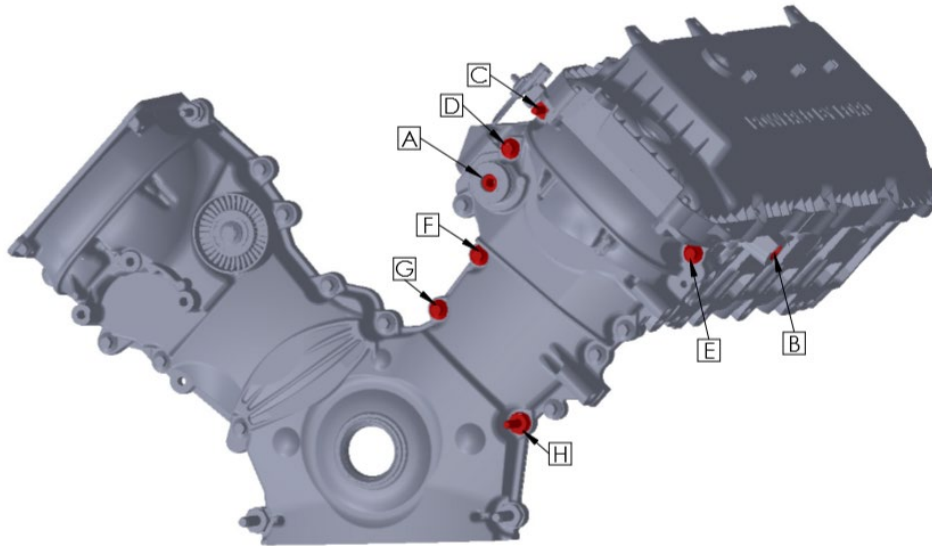
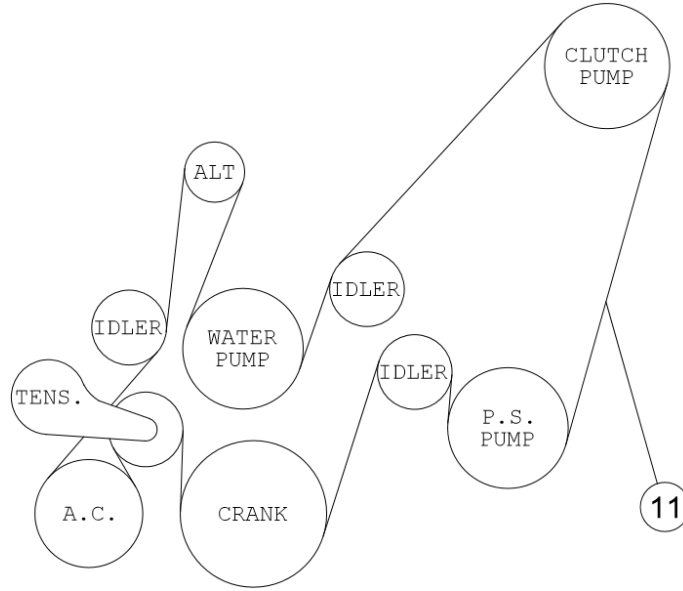

Disclaimer: (1.) Due to the custom nature and variation of all add-on systems of this type, no complete system kits are offered by the manufacturer, and any group of parts marketed as a kit is limited to only the individually defined parts in that specific kit. The system designer's rotating accessory components are not included, offered, or fully known by the manufacturer. In addition to the absence of the rotating accessory system, other potential components such as additional clamps, brackets, wear liners, hardware, or other items that may be required by the system designer must be identified and supplied by the actual system designer. (2.) Due to vehicle manufacturer's assembly tolerances, production changes, and installation variances, it is the buyer's responsibility to ensure adequate clearance for all components including space for and safe location of the fan, radiator, all lines, and wires. Check for possible movement, vibration, friction points, heat exposure and/or shifting of any and all components such as hoses, wires, and all other components including those that may otherwise be considered non-moving and/or unaffected by the installation (3.) The buyer is responsible for the entire installation of a mounting kit as the mounting kit is part of a custom process controlled by the buyer through their whole system design and directed installer as the installer evaluates, locates, routes, aligns, and tightens all components while determining if additional clamps, brackets, wear-liners, or other components may be required, beyond those included in the kit. Any additional items required, beyond those included in the kit, are to be provided at the expense of the buyer. (4.) The buyer is responsible for the development and communication of their whole system installation procedures, safety precautions, application, and use of the engine accessory mounting kit in their system, including efforts to maintain vehicle control and prevent pinch, wear, impact, and/or burn exposure on all hoses, wires, and other parts. (5.) The buyer is responsible for providing trained and experienced installation decision making with technical know-how to apply professional judgment that specifically applies to each individual installation. The buyers chosen installers must be qualified and experienced technicians that are familiar with the vehicle and accessory being mounted as well as the buyer's whole system design and installation procedures associated with the kit. (6.) The buyer is responsible for determining and achieving compliance to all regulatory issues that apply to the use of all products. (7.) The manufacturer reserves the right to make changes and/or improvements to any product at any time with or without notice.