



IMK33TM21-I8

2016-2020 International Durastar 4300-4400

2019-2024 International MV607

6.7L Cummins ISB I6 Diesel, w/ A/C, w/o OEM Dual Alternators

Requires 8-Groove, 127mm Diameter Clutch

For use w/ TM21 Direct Mount Compressor

Approximately 160% Overdriven w/ 127mm Diameter Clutch

INSTALLATION NOTES

1. The buyer is responsible for providing trained and experienced installation decision making with technical know-how to apply professional judgment that specifically applies to each individual installation.
2. Be sure to read and understand all available information including but not limited to instructions, warnings, sale terms, and warranties for the vehicle and all system components prior to attempting installation.
3. Disconnect the negative battery cables. Remove the passenger side inner fender. Remove the OEM fan belt. Remove the OEM alternator, alternator bracket, and lifting lug.
4. Cut the upper radiator hose as shown and install the steel hardline (23) with hose clamps (24).
5. Install the new alternator mounting bracket (1) with mounting hardware (2). Make certain both roll pins are tight against the front of the cylinder head when tightening bolts (2). Install the OEM alternator with OEM alternator mounting brace (6) that matches the OEM alternator bolt pattern with hardware (7-9). Use two washers (8) between the OEM alternator mounting brace (6) and the OEM alternator. Install wire harness support brace (22) to keep the harness off the OEM alternator. Leave bolts (7) loose for now.
6. Install the auxiliary A/C compressor mounting bracket (3) with hardware (4-5). Secure bolts (4), finger-tight bolts (5), tighten bolts (7). Adjust wire harness support brace (22) to keep the off the OEM alternator. Tighten bolts (5).
7. Install auxiliary A/C compressor to the auxiliary A/C compressor mounting bracket (3) with hardware (25-26).
8. Install smooth idler pulley assembly (10-12) onto alternator mounting bracket (1) at the lower location the furthest from the engine. Install grooved idler pulley assembly (13-15) onto alternator mounting bracket (1). Make sure the snap-rings on the idlers are facing towards the radiator.
9. Secure wire harness to water line near the fan pulley using hardware (16-21). Pull slack from harness to keep it off the OEM alternator. Keep clamps away from the fan pulley. Push harness through the OEM clamp toward driver side to keep away from fan pulley if necessary.
10. Install belt (27) as shown in the diagram. Check for any belt interference. Adjust if necessary.
11. Reinstall the negative battery cables. Start and check belt tracking. Reinstall the inner fender that was removed.

CAUTION: Before starting the engine, check to make certain no wires, hoses, etc. that may have been disturbed during installation do not come in contact with any hot or moving parts. Properly refill any fluids that may have been drained. Check the engine for leaks. Run the engine and check for proper belt tracking and clearance of any hoses, wires, etc. It is the installer's responsibility to correct/adjust, if necessary, before the vehicle is put into service.

CW Mill Equipment Co., Inc. Mounting Kit and Mounting Kit Component Disclaimer: (1.) Due to the custom nature and variation of all add-on systems of this type, no complete system kits are offered by the manufacturer, and any group of parts marketed as a kit is limited to only the individually defined parts in that specific kit. The system designer's rotating accessory components are not included, offered, or fully known by the manufacturer. In addition to the absence of the rotating accessory system, other potential components such as additional clamps, brackets, wear liners, hardware, or other items that may be required by the system designer must be identified and supplied by the actual system designer. (2.) Due to vehicle manufacturer's assembly tolerances, production changes, and installation variances, it is the buyer's responsibility to ensure adequate clearance for all components including space for and safe location of the fan, radiator, all lines, and wires. Check for possible movement, vibration, friction points, heat exposure and/or shifting of any and all components such as hoses, wires, and all other components including those that may otherwise be considered non-moving and/or unaffected by the installation (3.) The buyer is responsible for the entire installation of a mounting kit as the mounting kit is part of a custom process controlled by the buyer through their whole system design and directed installer as the installer evaluates, locates, routes, aligns, and tightens all components while determining if additional clamps, brackets, wear-liners, or other components may be required, beyond those included in the kit. Any additional items required, beyond those included in the kit, are to be provided at the expense of the buyer. (4.) The buyer is responsible for the development and communication of their whole system installation procedures, safety precautions, application, and use of the engine accessory mounting kit in their system, including efforts to maintain vehicle control and prevent pinch, wear, impact, and/or burn exposure on all hoses, wires, and other parts. (5.) The buyer is responsible for providing trained and experienced installation decision making with technical know-how to apply professional judgment that specifically applies to each individual installation. The buyers chosen installers must be qualified and experienced technicians that are familiar with the vehicle and accessory being mounted as well as the buyer's whole system design and installation procedures associated with the kit. (6.) The buyer is responsible for determining and achieving compliance to all regulatory issues that apply to the use of all products. (7.)

IMK33TM21-I8

2016-2020 International Durastar 4300-4400
 2019-2024 International MV607

6.7L Cummins ISB I6 Diesel, w/ A/C, w/o OEM Dual Alternators

Requires 8-Groove, 127mm Diameter Clutch
 For use w/ TM21 Direct Mount Compressor
 Approximately 160% Overdriven w/ 127mm Diameter Clutch

Parts List

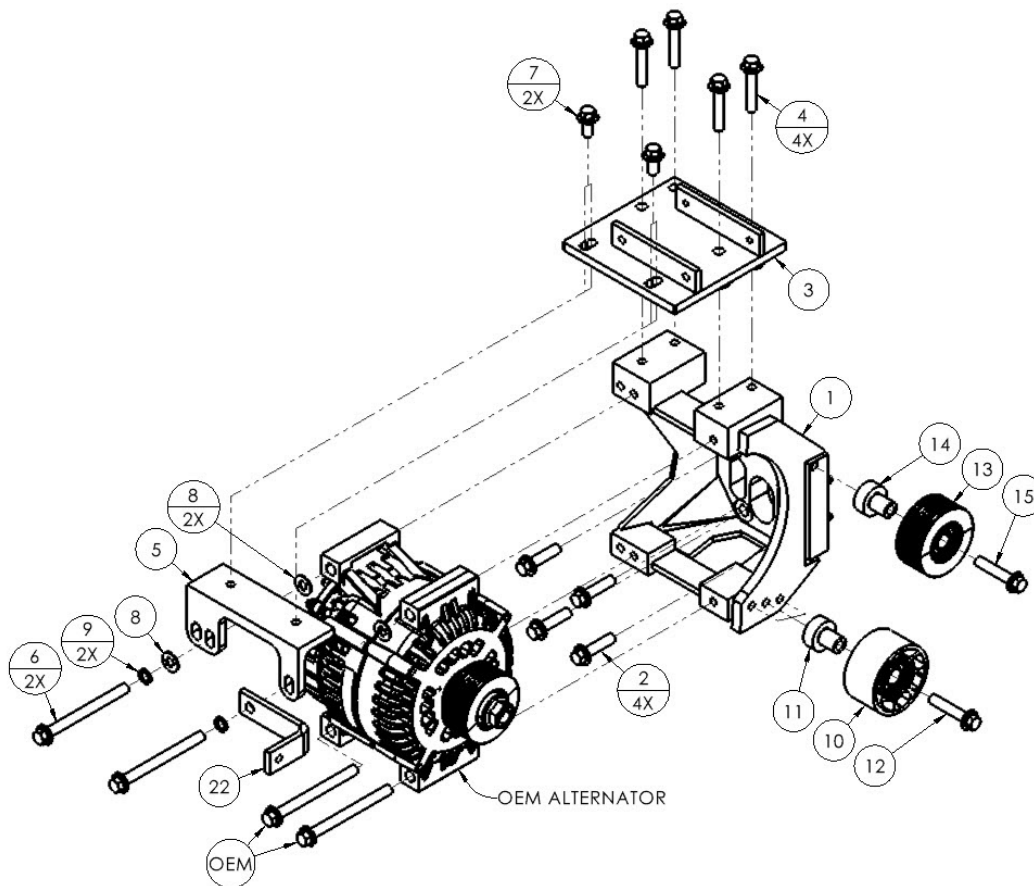

PARTS LIST							
Item	Part Number	Description	Qty.	Item	Part Number	Description	Qty.
Alternator Mounting Bracket				Grooved Idler Pulley Assembly			
1	IMB601	Mounting Bracket	1	11	IMB605	Machined Idler Bushing	1
Alternator Mounting Bracket Mounting Hardware				Smooth Idler Pulley Assembly			
2	1006933	M10-1.5 x 40mm 10.9Gr Hex Flg. Bolt	4	10	89101	Dayco Idler Pulley	1
Auxiliary A/C Compressor Mounting Bracket				Wire Harness Support Hardware (Not Shown)			
3	IMP33TM21-I8	Auxiliary A/C Compressor Mounting Bracket	1	12	1006934	M10-1.5 x 50mm 10.9Gr Hex Flg. Bolt	1
Auxiliary A/C Compressor Mounting Bracket Mounting Hardware				Wire Harness Support Brace			
4	1006934	M10-1.5 x 50mm 10.9Gr Hex Flg. Bolt	4	13	GPCD-8	Machined Idler Pulley	1
5	1008390	M10-1.5 x 20mm 10.9Gr Hex Flg. Bolt	2	14	IMB605	Machined Idler Bushing	1
OEM Alternator Mounting Brace				Wire Harness Support Hardware (Not Shown)			
6	IMB606	OEM Alternator Mounting Brace	1	15	1006934	M10-1.5 x 50mm 10.9Gr Hex Flg. Bolt	1
OEM Alternator Mounting Brace Mounting Hardware				Wire Harness Support Hardware (Not Shown)			
7	1005539	M10-1.5 x 110mm 10.9Gr Hex Bolt	2	16	1005110	#16 Adel Clamp	1
8	1002596	3/8" Thru Hard Flat Washer	3	17	1007886	#24 Adel Clamp	1
9	1003822	M10 Lock Washer	2	18	1006671	1/4"-20 x 3/4" Gr5 Hex Bolt	1
Smooth Idler Pulley Assembly				Wire Harness Support Hardware (Not Shown)			
10	89101	Dayco Idler Pulley	1	19	1009926	1/4"-20 Gr5 Hex Nut	1
OEM Alternator Mounting Hardware				Wire Harness Support Hardware (Not Shown)			
20	1002556	1/4" Thru Hard Flat Washer	1	21	1016304	1/4" Med Lock Washer	1
21	1016304	1/4" Med Lock Washer	1				
OEM Alternator Mounting Hardware				Wire Harness Support Hardware (Not Shown)			
22	IMB603	Wire Harness Support Brace	1				

CW **CW Mill Equipment Co., Inc.**
 14 Commerce Drive Sabetha, KS 66534
 Phone: (785) 284-3454
 Fax: (785) 284-3601
 Email: brackets@cwmill.com
 Website: www.cwkits.com

MOUNTING KITS

IMK33TM21-I8

2016-2020 International Durastar 4300-4400
 2019-2024 International MV607
 6.7L Cummins ISB I6 Diesel, w/ A/C, w/o OEM Dual Alternators

Requires 8-Groove, 127mm Diameter Clutch
 For use w/ TM21 Direct Mount Compressor
 Approximately 160% Overdriven w/ 127mm Diameter Clutch

Parts List

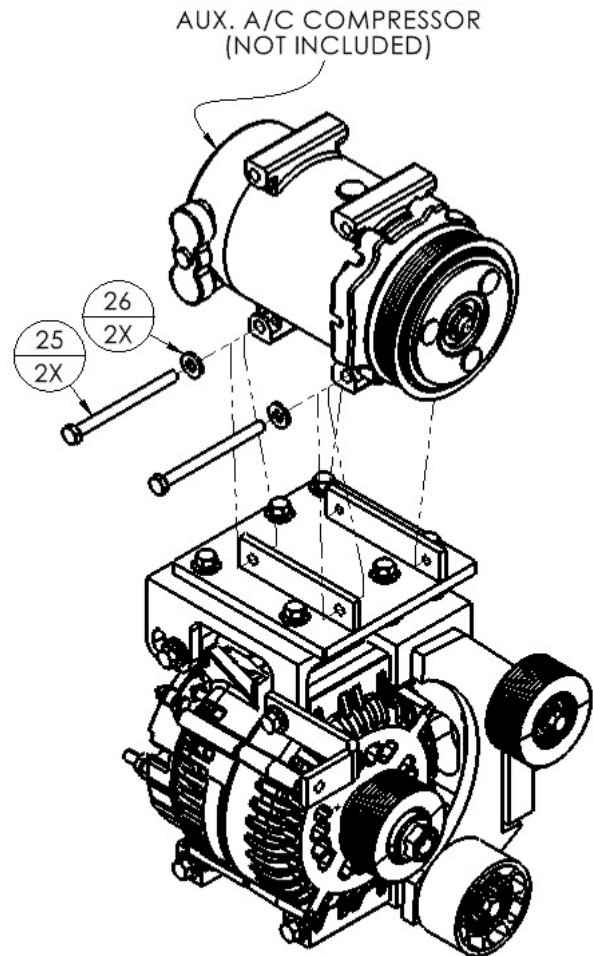
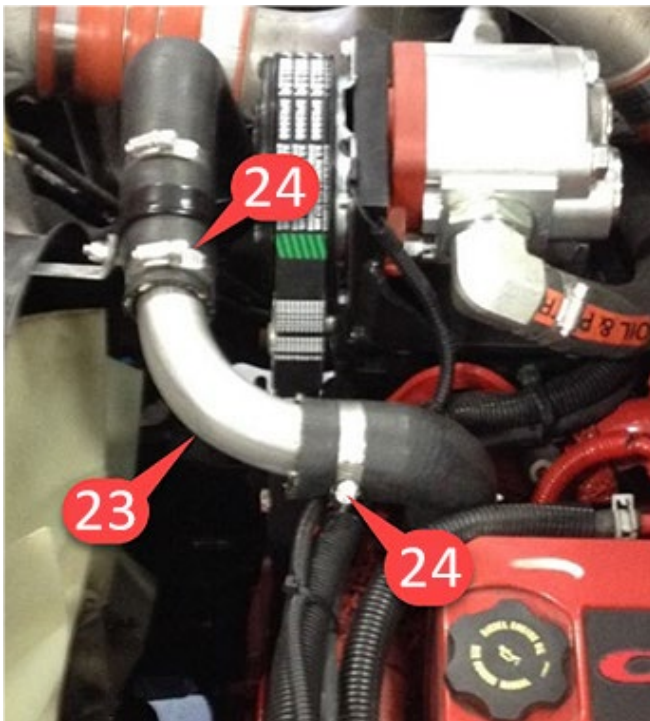

PARTS LIST							
Item	Part Number	Description	Qty.	Item	Part Number	Description	Qty.
Upper Radiator Hose Modification Hardware				Auxiliary A/C Compressor Mounting Hardware			
23	IMB33-01	Fabricated Steel Hardline	1	25	1011957	M8-1.25 x 100mm 10.9Gr Hex Bolt	2
24	1006199	#28 Hose Clamp	2	26	1010202	M8 Flat Washer	2

CW **CW Mill Equipment Co., Inc.**
 14 Commerce Drive Sabetha, KS 66534
 Phone: (785) 284-3454
 Fax: (785) 284-3601
 Email: brackets@cwmill.com
MOUNTING KITS Website: www.cwkits.com

IMK33TM21-I8

2016-2020 International Durastar 4300-4400
 2019-2024 International MV607

6.7L Cummins ISB I6 Diesel, w/ A/C, w/o OEM Dual Alternators

Requires 8-Groove, 127mm Diameter Clutch
 For use w/ TM21 Direct Mount Compressor

Approximately 160% Overdriven w/ 127mm Diameter Clutch

Belt Routings

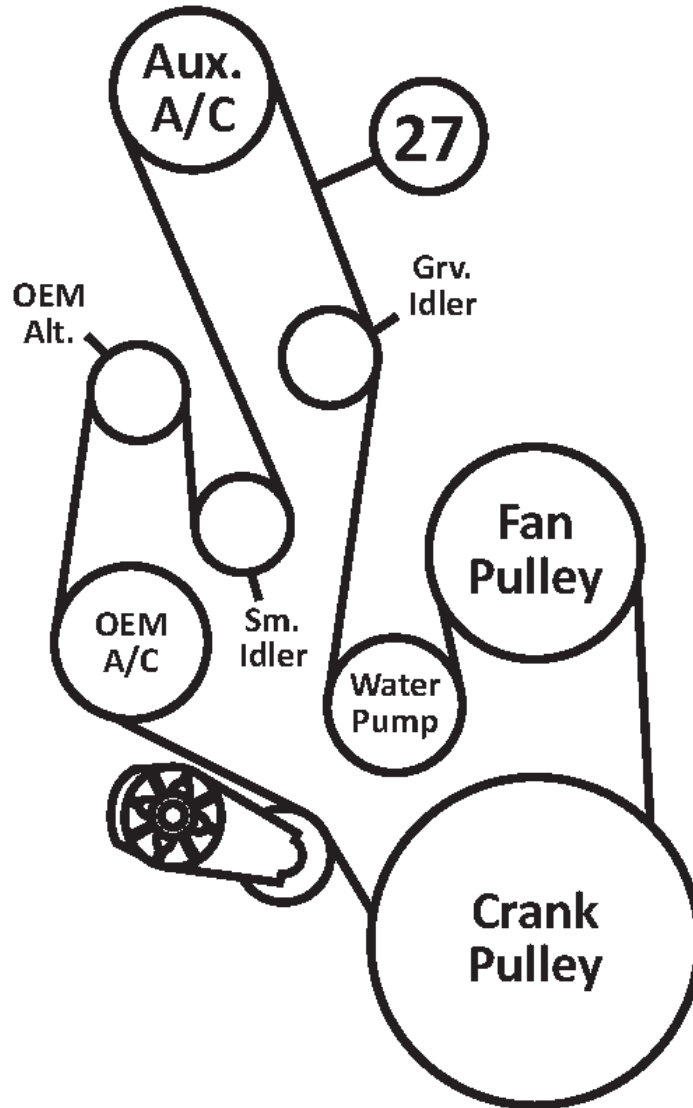

PARTS LIST			
Item	Part Number	Description	Qty.
Belt (Only One Belt Supplied)			
27	5081213	Dayco 8-Groove, 121.3" Belt	1

CW **CW Mill Equipment Co., Inc.**
14 Commerce Drive Sabetha, KS 66534
Phone: (785) 284-3454
Fax: (785) 284-3601
Email: brackets@cwmill.com
MOUNTING KITS Website: www.cwkits.com

IMK33TM21-I8

2016-2020 International Durastar 4300-4400
2019-2024 International MV607

6.7L Cummins ISB I6 Diesel, w/ A/C, w/o OEM Dual Alternators

Requires 8-Groove, 127mm Diameter Clutch

For use w/ TM21 Direct Mount Compressor

Approximately 160% Overdriven w/ 127mm Diameter Clutch

Mounting Locations

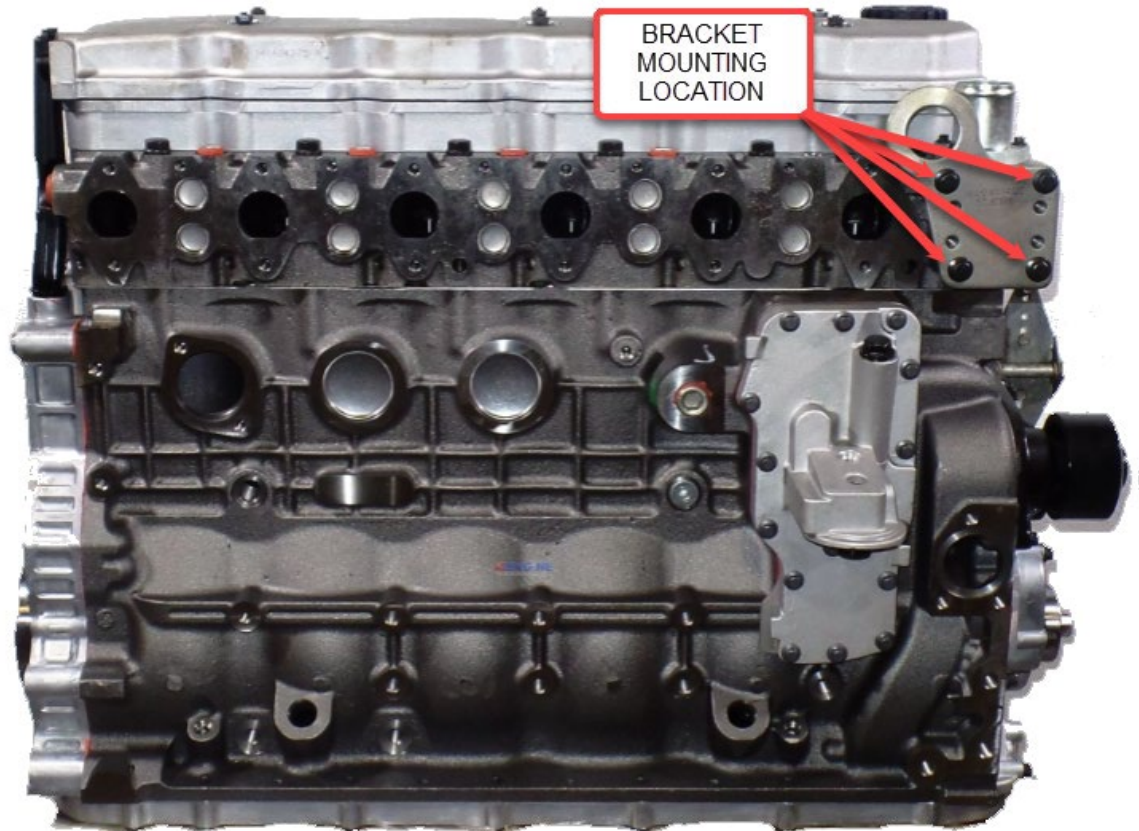

Mounting Locations