



## SMK 34SD508-8

Isuzu - 1999-2010 - N-Series

Chevy/GMC - 1999-2009 - W3500-5500

4.7/5.2L, I4 Diesel, W-WO AC,  
Requires 8 Groove Clutch

### INSTALLATION NOTES

---

1. Disconnect the negative battery cable. Remove the three bolts holding the fan shroud to the engine braces. Remove the four nuts from the fan clutch and remove the fan and fan clutch assembly from the engine. Loosen the alt. belt and A/C belt if equipped. Remove the fan clutch mounting plate from the water pump.  
*(Do not remove the pulley).*
2. Remove the four bolts holding the crank pulley on the crankshaft.  
(It may be necessary to use an impact to remove the bolts). Clean any dirt or rust from the inside of the OEM pulley. Install drive pulley (1) using four 16mm bolts (2) and lockwashers (3). Tighten securely. Install the aluminum fan spacer (4) and the OEM fan clutch adapter onto the water pump using bolts (5) and lockwashers (6).
3. Before the aux. A.C. bracket can be installed a boss on the front of the engine block (approx. 1ö) must be removed. This can be done using a hacksaw etc. (See Illustration)
4. Remove the lower alternator bracket. Remove the front two motor mount bolts. Install the aux. A.C. mounting bracket (7) and spacer (8) onto the engine block at that location using bolts (10) and lockwashers (9). Install the alternator on the new bracket using the O.E.M. bolt and nut. Install the compressor onto the bracket using bolts (13,14), nuts (15) and slide bushings (16). Install the tensioner (11) with bolt (12). Install the O.E.M. belt(s). Install the aux. A.C. belt.
5. Install the fan onto the water pump with the four OEM nuts. Using the 1/2 spacers, move the fan shroud ahead and hold in place with bolts provided. **NOTE:** The fan shroud brace on the lower passenger side will need to be removed and a nylon strap is used to hold it in place. Connect the negative battery cable. Check for clearance on all hoses, wires, etc.

**SMK 34SD508-8** Isuzu - 1999-2010 - N-Series Chevy/GMC - 1999-2009 - W3500-5500

4.7/5.2L, I4 Diesel, W-WO AC, Requires 8 Groove Clutch

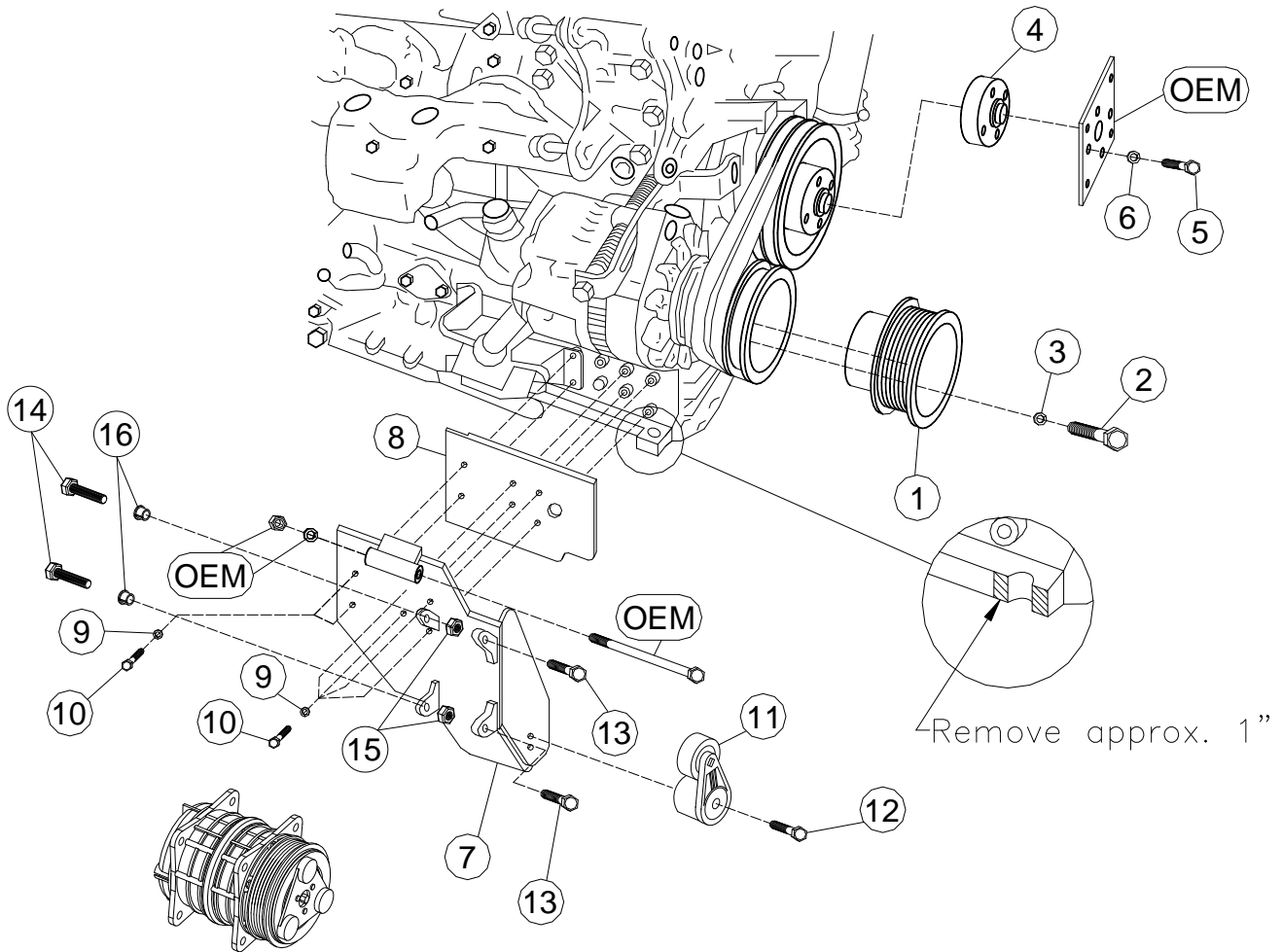

**PARTS LIST**

- |                          |                                 |
|--------------------------|---------------------------------|
| 1. SPC 348 (1)           | 12. 10mm x 55mm Bolt (1)        |
| 2. 16mm x 80 mm 1.5 (4)  | 13. 10mm x 30mm Flange (2)      |
| 3. 16mm LW (4)           | 14. 10mm x 40mm Flange (2)      |
| 4. FSO 4.7 (1)           | 15. 10mm Flange Nut (2)         |
| 5. 8mm x 35mm 10.9 (4)   | 16. 1255-0090 Slide Bushing (2) |
| 6. 8mm LW (4)            | 17. 8mm x 45mm (2) (Not Shown)  |
| 7. SMP 34SD508-8 (1)     | 18. 8mm FW (2) (Not Shown)      |
| 8. SPS 33 (1)            | 19. SP64-0.500 (2) (Not Shown)  |
| 9. 10mm LW (6)           | 20. Nylon Strap (1) (Not Shown) |
| 10. 10mm x 40mm Bolt (6) | 21. Belt 5080400 (1)            |
| 11. 89231-007 (1)        |                                 |